

GM2800C

5-Unit Rotary Mower

Owner's Operating Manual

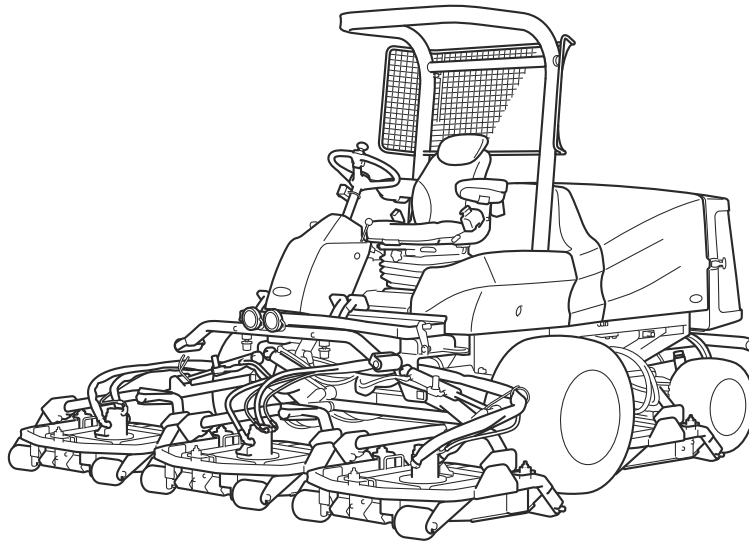

Serial No. GM2800C : 20009-

"Required reading"
Read this manual before using the machine.

BARONESS[®]
Quality on Demand

Ver.1.7

Greeting

Thank you for purchasing the Baroness product. This manual describes the proper handling, adjustment, and inspection of your product. We hope you will use the product safely, and take advantage of its best performance.

Keeping The Owner's Operating Manual

Keep this Manual in the bag located in the rear of the seat.

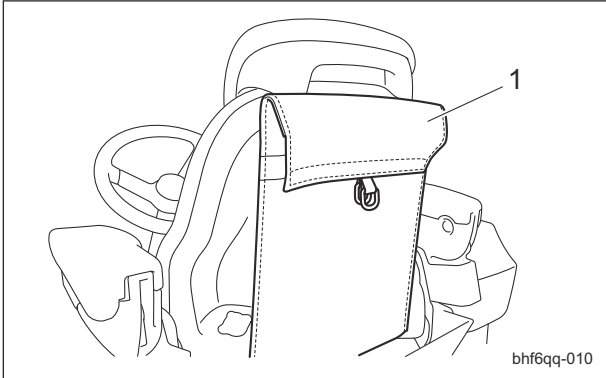

Keeping The Owner's Operating Manual_001

1	Bag
---	-----

QR Code

(*QR Code is a registered trademark of DENSO WAVE INCORPORATED.)

A QR code label is affixed on the machine.

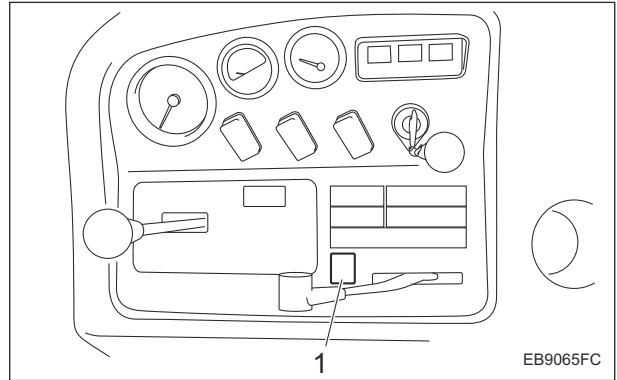

QR Code_001

1	QR code label
---	---------------

Scan the QR code with your smartphone for easy access to Baroness Manual Reference Service where you can browse Owner's Operating Manual and Parts Catalog.
<https://doc.baroness-international.com/manuals/GM2800C>



QR Code_002

Read this manual carefully to ensure that you thoroughly understand how to properly operate and maintain the product, and to avoid causing injury to yourself or others.

The operator is responsible for operating the product properly and safely.

Maintenance service for this machine should be performed by a mechanic with expertise.

If you have any questions concerning maintenance or genuine parts, please contact a Baroness dealer or Kyoisha.





When making inquiries about your product, please specify the model and serial number.

When loaning or transferring the product, please also provide this manual together with the product.

Kyoisha Co., Ltd.

Warning Symbols

This manual uses the following warning symbols for handling precautions that are important for your safety.

 <p style="text-align: center;">696cq5-001</p>	<p>Warning symbol</p>
<p>This symbol indicates the articles regarding “Danger,” “Warning,” or “Caution.” Those articles describe important safety precautions and so read them carefully to understand completely before operating the machine.</p> <p>Failure to adequately follow these safety precautions may cause an accident.</p>	
<p> Danger</p> <p>This symbol indicates that serious injury or death will occur if the warning is ignored.</p> <p> Warning</p> <p>This symbol indicates that serious injury or death may occur if the warning is ignored.</p> <p> Caution</p> <p>This symbol indicates that injury or damage to property may occur if the warning is ignored.</p> <p>Important</p> <p>This symbol indicates precautions on the mechanism of the machine.</p>	

Introduction

Precautionary Statement

 Caution

The information described in this manual is subject to change for improvement without prior notice.

When replacing parts, be sure to use genuine Baroness parts or parts designated by Kyoisha.

Note that the Baroness product warranty may not apply to defects caused by the use of parts from other companies.

Prior to use, carefully read the following manuals to thoroughly understand the contents for safe and correct operation.

- Baroness Owner's Operating Manual
- The Engine's Owner's Manual
- The Battery's Owner's Manual

Purpose

This product is intended for cutting turf grass at golf courses.

Do not use this product in any way other than its intended purpose, and do not modify this product.

Operating this product for other purposes and modifying it may be very dangerous and may cause damage to the product.

In addition, this product is not authorized for operation as a special motor vehicle. Do not operate it on public roads.

Safety	Page 1-1	Precautions for Maintenance	Page 6-2
Safe Operating Practices	Page 1-2	Operations before Maintenance	Page 6-2
Disposal	Page 2-1	Jacking Up The Machine	Page 6-3
Recycle and Waste Disposal	Page 2-2	Inspection and Cleaning	Page 6-4
Product Overview	Page 3-1	Supplying Fluids	Page 6-8
Specifications	Page 3-2	Greasing	Page 6-12
Names of Each Section	Page 3-4	Lubrication	Page 6-15
Regulation Decals	Page 3-6	Adjustment	Page 6-16
Safety Signs and Instruction Signs	Page 3-7	Replacement	Page 6-22
Operation Decals	Page 3-15	Storage	Page 6-36
Description of Functions	Page 4-1	Repair	Page 7-1
Proximity Sensors	Page 4-2	Precautions for Repair	Page 7-2
Relays	Page 4-2	Adjustment	Page 7-2
Key Switch	Page 4-2	Replacement	Page 7-4
Knife Rotation Switch	Page 4-3	Towing	Page 7-5
2WD/4WD Selector Switch	Page 4-3	Appended Table	Page 8-1
Light Switch	Page 4-3	Tightening Torques	Page 8-2
Traction Assist Switch	Page 4-4	Daily Check List	Page 8-7
Mower Lock Lever (Latch)	Page 4-4	Maintenance Schedule	Page 8-9
Mower Deck Up/Down Lever	Page 4-4	List of Adjusted Values	Page 8-12
Throttle Lever	Page 4-5	Records	Page 9-1
Diff-Lock Switch	Page 4-5	Daily Check Records	Page 9-2
Traveling Pedal	Page 4-6	Maintenance Records	Page 9-5
Brake Pedal	Page 4-6		
Parking Brake Lever	Page 4-7		
Instruments on the Operation Panel	Page 4-7		
Safety Device	Page 4-9		
Warning Mechanisms	Page 4-10		
Handling Instructions	Page 5-1		
Operations before Service	Page 5-2		
Inspection before Use	Page 5-3		
Adjustment before Work	Page 5-10		
Start/Stop of Engine	Page 5-11		
Parking and Stopping	Page 5-13		
Move	Page 5-13		
Cutting Work	Page 5-13		
Transporting	Page 5-14		
Cleaning after Use	Page 5-14		
Storage	Page 5-16		
Maintenance	Page 6-1		

GM2800C

Contents

Safe Operating Practices Page 1-2

Training Page 1-2

Preparation Page 1-2

Operation Page 1-3

Maintenance Page 1-4

Storage Page 1-5



Safety

Failure to adequately follow these safety precautions may cause an accident resulting in injury or death.

Danger

This product is designed to ensure safe operation and has been tested and inspected thoroughly before shipment from the factory. The product is equipped with safety devices to prevent accidents.

However, whether the product demonstrates its original performance level depends on the manner in which it is operated and handled, as well as the manner in which it is managed on a daily basis.

Inappropriate use or management of the product may result in injury or death.

Observe the following safety instructions to ensure safe operation.

Safe Operating Practices

Training

1. Read this manual and other training material carefully.

Be familiar with the controls, safety signs, and the proper use of the equipment.

2. If the operator or mechanic can not read the language used in this manual, it is the owner's responsibility to explain this material to them.

3. All operators and mechanics should seek and obtain professional and practical instruction.

The owner is responsible for training the users.

Such instruction should emphasize:

- [1] The need for care and concentration when working with ride-on machines.

- [2] Control of a ride-on machine sliding on a slope will not be regained by the application of the brake.

The main reasons for loss of control are

- Insufficient wheel grip
- Being driven too fast
- Inadequate braking
- The type of machine is unsuitable for its task
- Lack of awareness of the effect of ground conditions, especially slopes
- Incorrect hitching and load distribution

4. Never allow children or people unfamiliar with these instructions to use or service the machine.
Local regulations may restrict the age of the operator.
5. The owner/user can prevent and is responsible for accidents or injuries occurring to themselves, other people, or property.
6. Keep in mind that the owner, operator, and mechanic are responsible for accidents or hazards occurring to other people or their property.
7. The ROPS is an integral and effective safety device.
Do not remove or alter the ROPS.
8. Replace a damaged ROPS.
Do not repair or alter.
9. You can find additional safety information where needed throughout this manual.
10. Determine the left and right sides of the machine from the normal operating position.

Preparation

1. Evaluate the terrain to determine what accessories and attachments are needed to properly and safely perform the job.
Only use accessories and attachments approved by the manufacturer.
2. While operating, always wear substantial footwear, long trousers, hard hat, safety glasses, mask, and ear protection.
Long hair, loose clothing, or jewelry may get tangled in moving parts.
Do not operate the equipment when barefoot or wearing open sandals.
3. Inspect the area where the equipment is to be used and remove all objects such as rocks, toys and wire which can be thrown by the machine.
4. Keep children out of the operating area and under the watchful care of a responsible adult other than the operator.
5. Exercise care in the handling of fuel.

Warning

Fuel is highly flammable.
Take the following precautions:

- [1] Store fuel in containers specifically designed for this purpose.

- [2] Add fuel before starting the engine.
Never remove the cap of the fuel tank or add fuel while the engine is running or when the engine is hot.
- [3] Refuel outdoors only and do not smoke while refueling.
- [4] If fuel is spilled, do not attempt to start the engine but move the machine away from the area of spillage and avoid creating any source of ignition until petrol vapours have dissipated;
- [5] Replace all fuel tanks and container caps securely.
6. Check that operator's presence controls, safety switches and shields are attached and functioning properly.
Do not operate unless they are functioning properly.
7. If the brake operation is faulty, be sure to adjust or repair them before operating the machine.
8. Replace faulty mufflers.
9. Before using, always visually inspect to see that the rotary knives, rotary knife bolts, and cutter assembly are not worn or damaged.
Replace worn or damaged rotary knives and bolts in sets to preserve balance.
10. On multi-rotary knife machines, take care as rotating one rotary knife can cause other rotary knives to rotate.
5. Never operate the machine with damaged guards, shields, or without safety protective devices in place.
Be sure all interlocks are attached, adjusted properly, and functioning properly.
6. Keep hands and feet away from the rotating parts.
7. Do not carry passengers.
8. Never operate while people, especially children, or pets are nearby.
9. Only operate in good light, keeping away from holes and hidden hazards.
10. Do not operate the machine when there is the risk of lightning.
11. Do not stop or start suddenly.
12. Look behind and down before backing up to be sure of a clear path.
13. Slow down and use caution when making turns and crossing roads and sidewalks.
14. Use care when approaching blind corners, shrubs, trees, or other objects that may obscure vision.
15. Do not take your eyes off the road ahead.
Do not operate the machine with no hands.
16. Remember there is no such thing as a safe slope.
Travel on grass slopes requires particular care.
To guard against overturning, follow these instructions.

Operation

1. Do not operate the machine under the influence of alcohol or drugs.
2. Do not operate the engine in a confined space where dangerous carbon monoxide fumes can collect.
3. Be sure all drives and shift are in neutral and parking brake is engaged before starting engine.
Only start engine from the operator's position.
Use seat belts if provided.
4. Do not change the engine governor settings or overspeed the engine.
Operating the engine at excessive speed may increase the hazard of personal injury.
- [1] Do not stop or start suddenly when going up or downhill.
- [2] Engage clutch slowly, always keep machine in gear, especially when traveling downhill.
- [3] Machine speeds should be kept low on slopes and during turns.
- [4] Stay alert for humps and hollows and other hidden hazards.
17. Never use the machine on a slope with an angle of gradient that is greater than that specified or in a place where there is a danger of the machine slipping.
18. Use extra care while operating machine with a grass catcher or other attachments.
They can affect the stability of the machine.
19. Disengage drive to the cutting unit(s), when other than operating.

Safety

20. Do the following before leaving the operator's position.
 - [1] Stop on level ground.
 - [2] Disengage the all drives.
 - [3] Set the parking brake.
 - [4] Stop the engine.
 - [5] Remove the ignition key.
21. Stop the engine in the following conditions.
 - [1] Before refuelling.
 - [2] Before making height or depth adjustment unless adjustment can be made from the operator's position.
 - [3] Before clearing blockages.
 - [4] Before checking, cleaning or working on the machine.
 - [5] After striking a foreign object or if an abnormal vibration occurs.
Inspect the machine for damage and make repairs before restarting and operating the equipment.
22. Reduce the throttle setting during engine run-out.
23. Never raise mower deck with the rotary knives running.
24. Do not mow in reverse unless absolutely necessary.
25. Do not direct discharge material toward anyone.
Avoid discharging material against a wall or obstruction.
Material may ricochet back toward the operator.
26. Take care when loading or unloading the machine into a trailer or a truck.
Load or unload the machine in a flat and safe place.
Before loading or unloading, set the parking brake on the truck or trailer, stop the engine, and chock the wheels.
When transporting the machine on a truck or a trailer, set the parking brake, stop the engine, and fasten the machine to the truck with a rope or other suitable restraining device that has sufficient strength.
When using a running board, select one with sufficient strength, length, and width and that will not cause the machine to slip.
27. Close the fuel valve before transporting the machine.

Maintenance

1. Never allow untrained personnel to service machine.
2. Implement the following work before adjusting, cleaning or repairing.
 - [1] Stop the machine on level ground.
 - [2] Disengage drive to the cutting unit(s).
 - [3] Lower the cutting unit(s) and/or attachment(s).
 - [4] Set the parking brake.
 - [5] Stop the engine.
 - [6] Remove the ignition key.
 - [7] Wait for all movement to stop.
3. Allow the engine/muffler to cool before checking/maintenance.
4. To reduce the fire hazard, keep hot parts such as the engine and silencer/muffler, battery compartment and fuel storage area free of grass, leaves, or excessive grease.
Clean up oil or fuel spillage.
5. Appropriately manage and correctly use the tools necessary for servicing or adjusting the machine.
6. Disconnect battery before making any repairs.
Disconnect the negative terminal first and the positive last.
Reconnect positive first and negative last.
7. Use jack stands to support components when required.
8. Keep hands and feet away from moving parts.
If possible, do not make adjustments with the engine running.
9. Make sure that parts such as wires are not touching each other and that their covers have not come off.
10. Keep all parts in good working condition and all hardware tightened.
Replace all worn or damaged decals.
11. Keep all nuts, bolts and screws tight to be sure the equipment is in safe working condition.
12. Carefully release pressure from components with stored energy.
13. Be sure to depressurize the hydraulic system before performing maintenance operations on it such as removing hydraulic equipment.

14. Check whether line connectors in the hydraulic system are properly tightened. Before applying hydraulic pressure, check the connections of the hydraulic pressure lines and the condition of the hoses.
 15. When checking the hydraulic circuit for pinhole leaks or oil leakage from nozzles, do not use your hands.
Use items such as paper or corrugated cardboard to find leakage points.
Be extremely careful with high-pressure oil as it may pierce your skin, resulting in an injury.
If fluid is injected into the skin it must be surgically removed within a few hours by a doctor familiar with this form of injury or gangrene may result.
 16. Use care when checking the rotary knives. Wrap the rotary knives or wear gloves, and use caution when servicing them.
Only replace rotary knives.
Never straighten or weld them.
 17. On multi-rotary knife machines, take care as rotating one rotary knife can cause other rotary knives to rotate.
 18. Charge batteries in an open well ventilated area, away from spark and flames.
Unplug charger before connecting or disconnecting from battery.
Wear protective clothing and use insulated tools.
 19. If the fuel tank has to be drained, do this outdoors.
7. Swallowing engine coolant can cause injury or death; keep out of reach from children and pets.

Storage

1. When machine is to be parked, stored, or left unattended, lower the cutting unit(s) and/or attachment(s) unless a positive mechanical lock is provided.
2. Allow the engine to cool before storing in any enclosure.
3. Only cover the machine with a sheet after hot parts have sufficiently cooled down.
4. Never store the equipment with fuel in the tank inside a building where fumes may reach an open flame or spark.
5. If the engine is provided with a shut-off valve, shut off valve while storing or transporting.
6. Do not store fuel near flames.

Recycle and Waste Disposal Page 2-2

About RecyclePage 2-2

About Waste Disposal Page 2-2

Disposal

Recycle and Waste Disposal

About Recycle

Recycling battery etc. is recommended for environmental conservation and economical use of resources.

It may be required by local laws.

About Waste Disposal

Make sure that waste generated when servicing or repairing the machine is disposed of in accordance with local regulations. (e.g. waste oil, antifreeze, rubber products, and wires etc.)

Specifications Page 3-2

SpecificationsPage 3-2

Sound Pressure Level Page 3-3

Sound Power Level Page 3-3

Vibration Level Page 3-3

Names of Each Section Page 3-4

Regulation DecalsPage 3-6

Positions of Regulation Decals Page 3-6

Description of Regulation Decals Page 3-6

Safety Signs and Instruction Signs Page 3-7

About Safety Signs and Instruction
SignsPage 3-7

Positions of Safety Decals and
Instruction Decals Page 3-7

Description of Safety Decals and
Instruction Decals Page 3-9

Operation Decals Page 3-15

Positions of Operation Decals Page 3-15

Description of Operation Decals Page 3-15

Product Overview

Specifications

Specifications

Model		GM2800C	
Name		5-Unit Rotary Mower	
Dimensions	Total length	370 cm	145.67 in
	Total width	During operation	300 cm 118.11 in
		During transport	230 cm 90.55 in
	Total height	Roof	230 cm 90.55 in
Steering wheel		165 cm 64.96 in	
Weight	Machine (empty fuel tank) with ROPS, Roof	2,084 kg	4594.43 lb
Minimum turning radius		320 cm	125.98 in
Engine	Model	Kubota V2403-M-T	
	Type	Vertical water-cooled 4-cycle diesel engine with turbocharger	
	Total displacement	2,434 cm ³ (2.434 L)	148.51 cu.in.
	Maximum output	-	
	Rated output	44.0 kW (59 PS)/2,700 rpm	
Fuel tank capacity		Diesel 51.0 dm ³ (51.0 L)	Diesel 13.47 U.S.gal.
Fuel consumption		248 g/kW · h (rated output)	182 g/PS · h (rated output)
Engine oil capacity		9.7 dm ³ (9.7 L)	2.56 U.S.gal.
Coolant volume		12.0 dm ³ (12.0 L)	3.17 U.S.gal.
Hydraulic tank capacity		44.0 dm ³ (44.0 L)	11.62 U.S.gal.
Transmission oil capacity		-	
Operating width (Mowing width)		280 cm	110.24 in
Operating height (Mowing height)		20.0 - 91.5 mm	0.787 - 3.602 in
Number of Blades		5	
Drive	Traveling	HST (2WD/4WD selectable)	
	Mowing	Hydraulic	
Speed (HST)	Forward	2WD	0 – 16.0 km/h 0 - 9.94 mph
		4WD	0 – 10.5 km/h 0 - 6.53 mph
	Reverse	0 - 6.0 km/h 0 - 3.73 mph	
Speed (Mechanical)		-	
Efficiency		20,160 m ² /h (9.0 km/h (4WD) x mowing width x 0.8)	4.98 acres/hour (5.59 mph (4WD) x mowing width x 0.8)
Maximum inclination for operation		15 degrees	
Tire size	Front wheel	29 x 14.00 - 15	
	Rear wheel	20 x 12.00 - 10	
Tire pneumatic pressure	Front wheel	150 kPa (1.5 kgf/cm ²)	22 psi
	Rear wheel	140 kPa (1.4 kgf/cm ²)	20 psi
Battery		105D31R	
Engine plug		—	

The factory default maximum engine rpm is 2,600 rpm.

Sound Pressure Level

Sound Pressure Level

This machine was confirmed to have a continuous A-weighted sound pressure level of 89dB by measuring identical machines in accordance with the procedure specified in ISO 5395-1:2013.

Sound Power Level

Sound Power Level

This machine was confirmed to have a sound power level of 105dB by measuring identical machines in accordance with the procedure specified in ISO5395-1:2013.

Vibration Level

Hand-Arm Vibration

This machine was confirmed not to exceed a vibration level of 2.5 m/s^2 to hands and arms by measuring identical machines in accordance with the procedure specified in ISO 5395-1:2013.

Uncertainty $K = 0.2 \text{ m/s}^2$

Whole Body Vibration

This machine was confirmed not to exceed a vibration level of 0.5 m/s^2 to the whole body by measuring identical machines in accordance with the procedure specified in ISO 5395-1:2013.

Uncertainty $K = 0.2 \text{ m/s}^2$

Product Overview

Names of Each Section

Overall view A

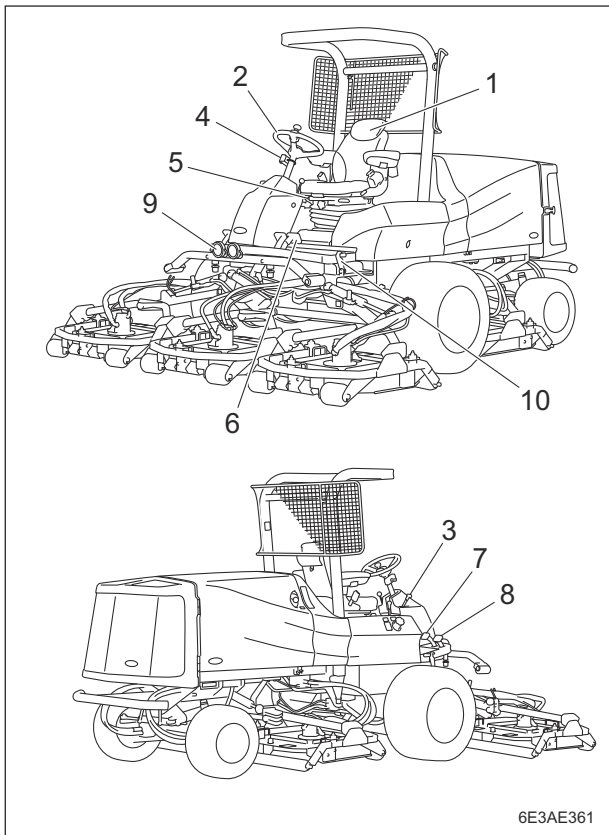

Names of Each Section_001

1	Seat
2	Steering wheel
3	Tilt lever
4	Diff-lock switch
5	Parking brake lever
6	Brake pedal
7	Forward pedal
8	Reverse pedal
9	Light
10	Mower lock lever (latch)

Overall view B

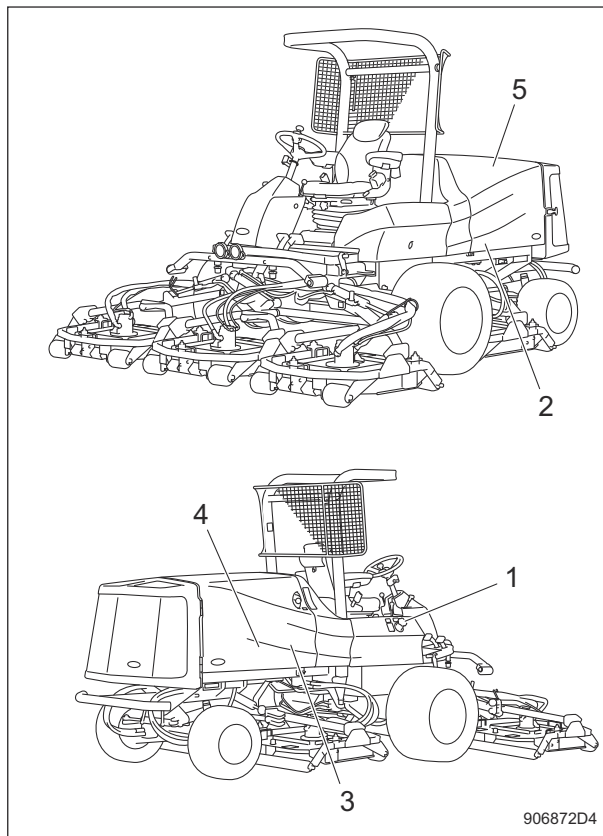

Names of Each Section_002

1	Fuel tank
2	Fuel filter
3	Water separator
4	Battery
5	Hood

Product Overview

Overall view C

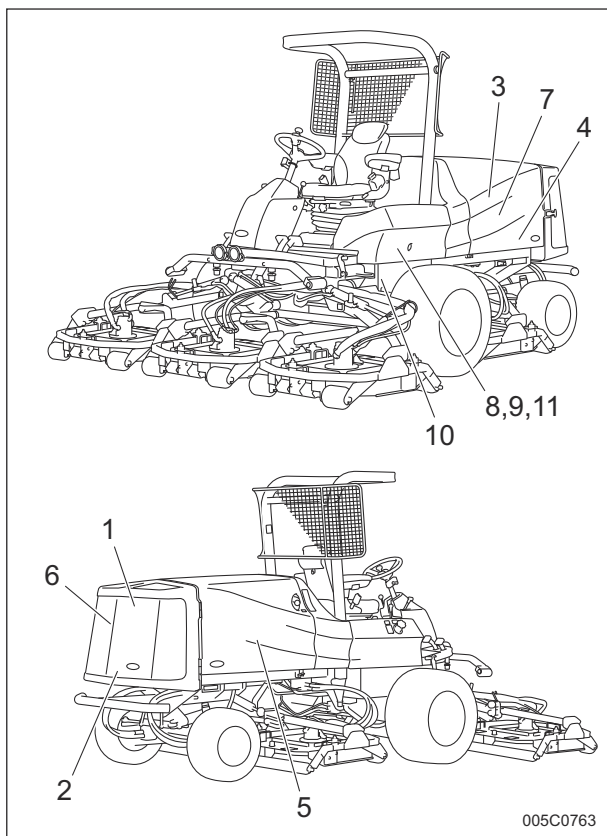

Names of Each Section_003

1	Radiator
2	Radiator cover
3	Engine
4	Engine oil filter
5	Reserve tank
6	Oil cooler
7	Air cleaner
8	Hydraulic tank
9	Air breather
10	Hydraulic oil line filter
11	Hydraulic oil suction filter

Overall view D

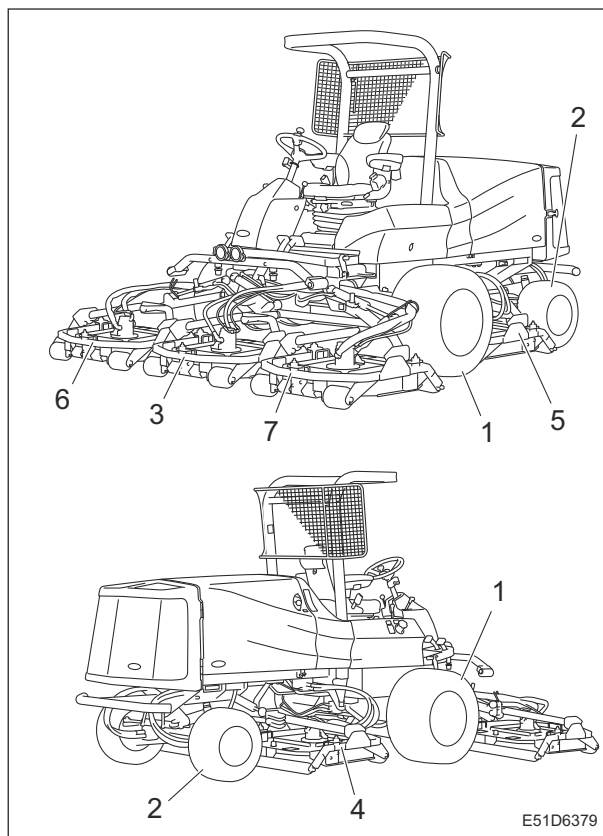

Names of Each Section_004

1	Front tire
2	Rear tire
3	Mower deck #1
4	Mower deck #2
5	Mower deck #3
6	Mower deck #4
7	Mower deck #5

Product Overview

Product Overview

Operation panel

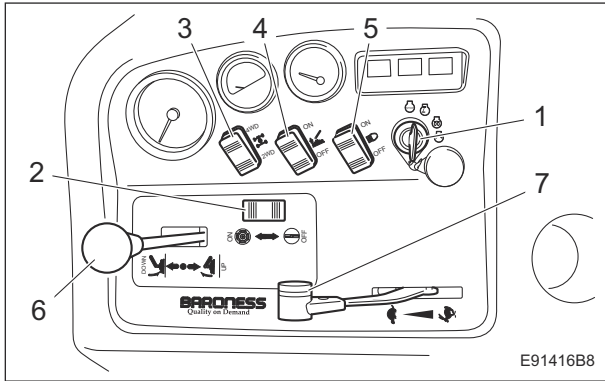

Names of Each Section_005

1	Key switch
2	Knife rotation switch
3	2WD/4WD selector switch
4	Traction assist switch
5	Light switch
6	Mower deck up/down lever
7	Throttle lever

Description of Regulation Decals

Serial Number Plate

The serial number plate indicates the model and serial number of the machine.

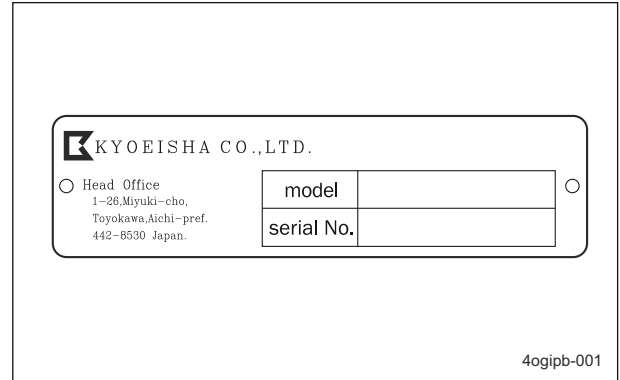

Serial Number Plate_001

ROPS Compliance Decal

The ROPS compliance decal indicates the manufacturer, model, etc., in accordance with International Standard ISO 21299:2009.

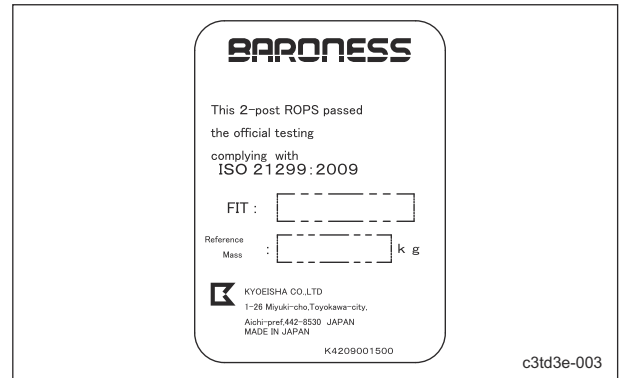

ROPS Compliance Decal_001

ROPS Caution Decal

ROPS caution decal describes the following caution messages.

- Replace damaged ROPS.
- Do not repair or revise.

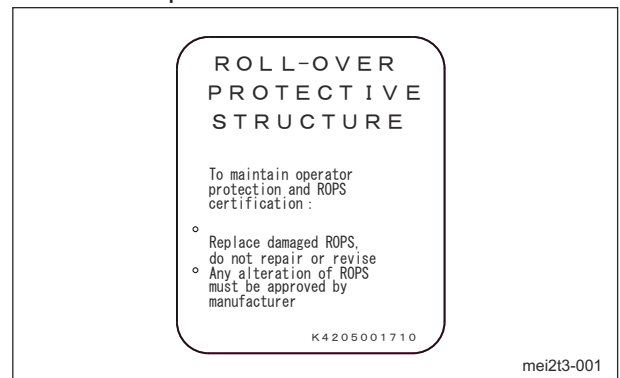

ROPS Caution Decal_001

Regulation Decals

Positions of Regulation Decals

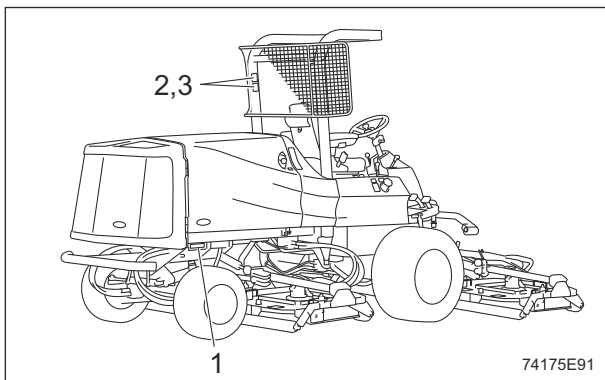

Positions of Regulation Decals_001

1	Serial number plate
2	ROPS compliance decal
3	ROPS caution decal

Safety Signs and Instruction Signs

About Safety Signs and Instruction Signs

Important

Safety decals and instruction decals are attached to this product. Make sure that they are preserved in their entirety. If they are damaged, become dirty, or peel off, replace them with new ones.

Part numbers for decals that need to be replaced are listed in the parts catalog. Order them from a Baroness dealer or Kyoisha.

Positions of Safety Decals and Instruction Decals

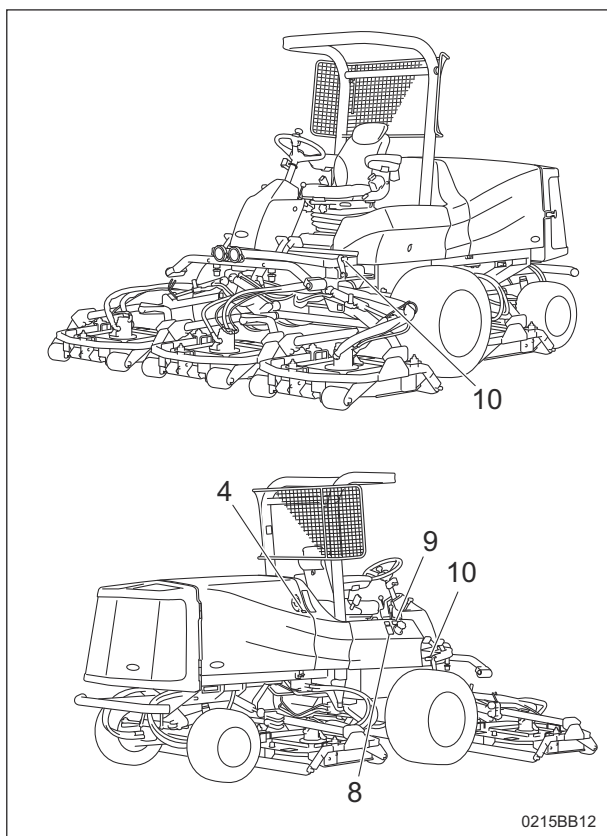

Positions of Safety Decals and Instruction Decals_001

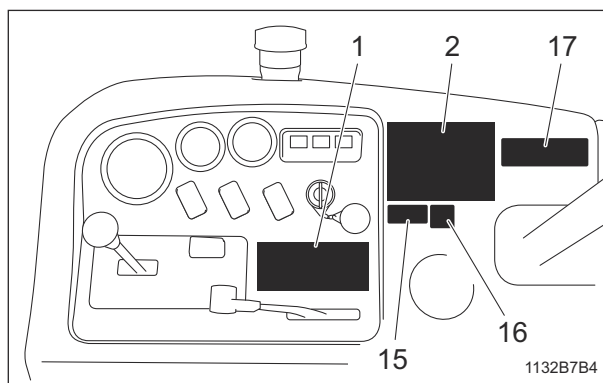

Positions of Safety Decals and Instruction Decals_002

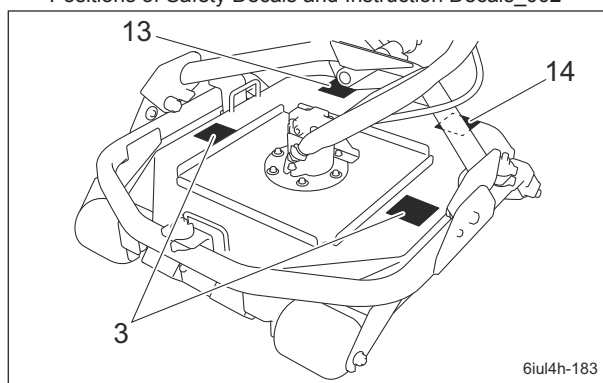

Positions of Safety Decals and Instruction Decals_003

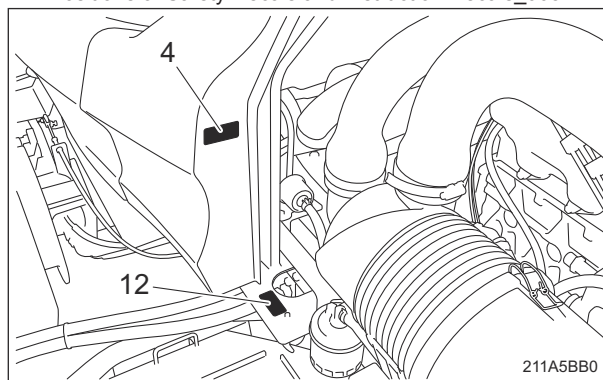

Positions of Safety Decals and Instruction Decals_004

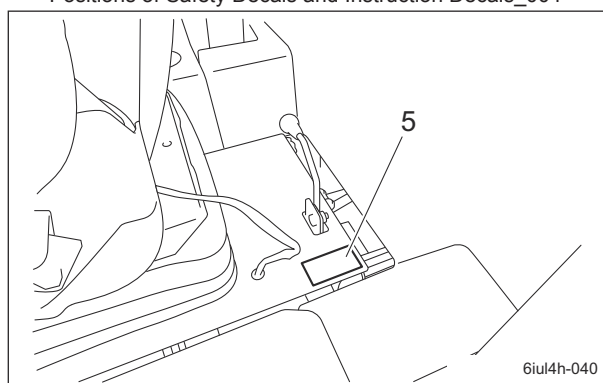

Positions of Safety Decals and Instruction Decals_005

Product Overview

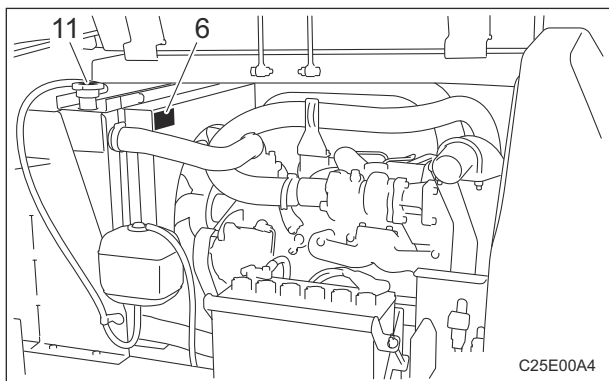

Positions of Safety Decals and Instruction Decals_006

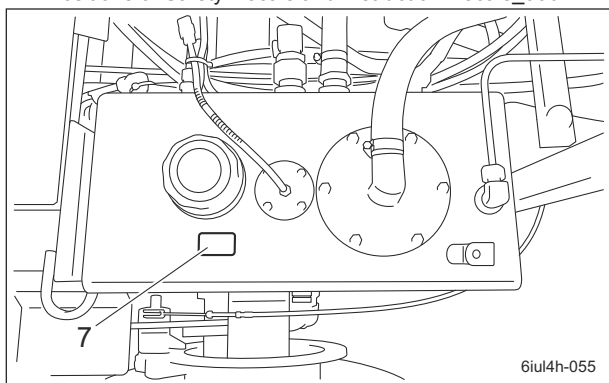

Positions of Safety Decals and Instruction Decals_007

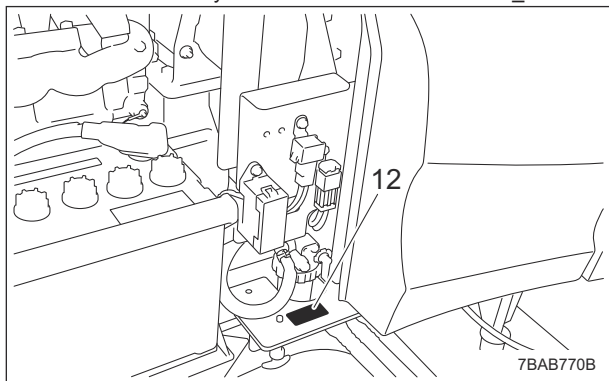

Positions of Safety Decals and Instruction Decals_008

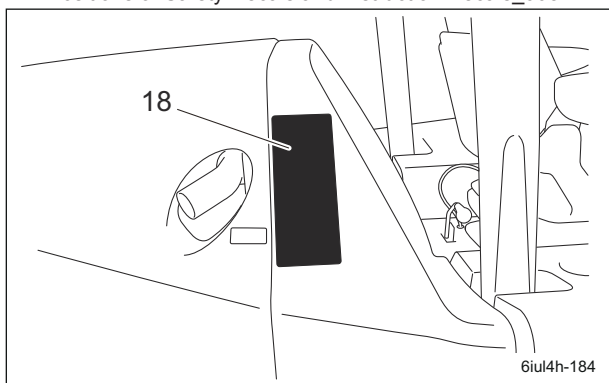

Positions of Safety Decals and Instruction Decals_009

1	Operation decal
2	Engine start/stop decal
3	Caution to mutilation decal
4	Caution to hot parts decal
5	Caution for getting caught decal
6	Caution to rotating object decal
7	Hydraulic oil decal
8	Diesel fuel filler port decal
9	Fire prohibited decal
10	Caution for mower lock decal
11	Caution for spouting coolant decal
12	Caution for getting pinched decal
13	Caution to thrown object decal
14	Caution for hand or leg injury decal
15	Caution exhaust gas decal
16	Caution to noise decal
17	2WD/4WD selector important decal
18	Maintenance decal

Description of Safety Decals and Instruction Decals

Operation Decal

GM2800C0903Z0
STICKER, OPERATING

1.



Read the Owner's Operating Manual.

2.



Apply the parking brake, stop the engine, remove the ignition key, and then leave the machine.

3.

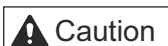

Thrown objects - Be sure that people around the machine keep a safe distance away.

4.



May cut your hand or leg - Keep hands and feet away from moving parts.

5.



Rollover - Do not work on slopes of 15 degrees or more.
When you descend a slope, lower the mower decks and then drive at low speed.
For ROPS equipped machine, fasten your seatbelt.

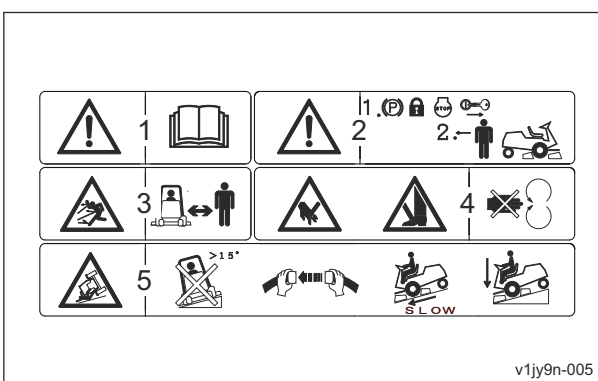

Operation Decal_001

Engine Start/Stop Decal

K4205001630

Decal, start/stop engine

1.



Read the Owner's Operating Manual.

2. Procedure to Start Engine

Read the Owner's Operating Manual.

[1] Sit on the seat.

[2] Turn the key to the "GLOW" position, and then wait for the thermo-start lamp to turn off.

[3] Turn the key to the "START" position.

[4] Depress the brake pedal to release the parking brake.

3. Procedure to Stop Engine

Read the Owner's Operating Manual.

[1] Set the knife rotation switch to the "Stop" position, and then raise the mower decks.

[2] Apply the parking brake.

[3] Turn the key to the "STOP" position, and then remove it.

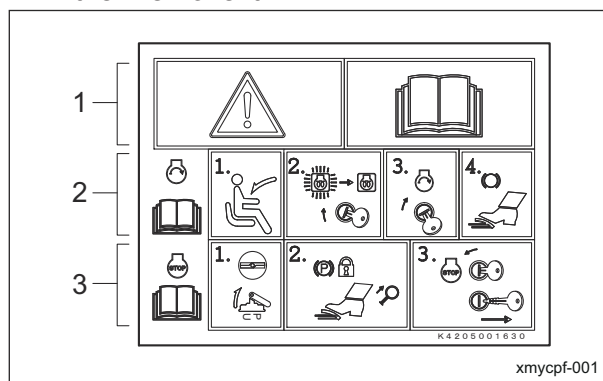

Engine Start/Stop Decal_001

Product Overview

Caution to Mutilation Decal

K4205001600
DECAL, CAUTION TO MUTILATION

Warning

May cut your hand or leg - Stop the cutter rotation and engine. Otherwise you may get injured.

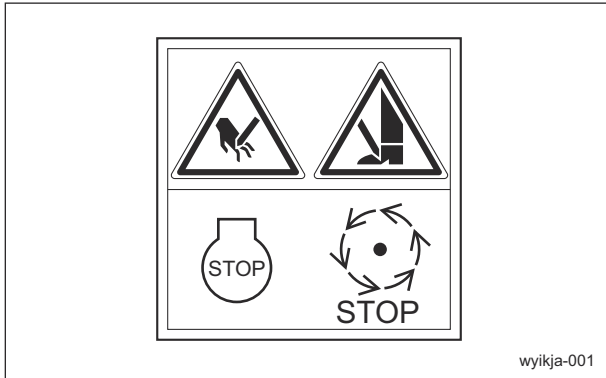

Caution to Mutilation Decal_001

Caution for Getting Caught Decal

K4205001580
DECAL, CAUTION TO GET CAUGHT

Caution

May get pinched - There is a risk of being pinched.

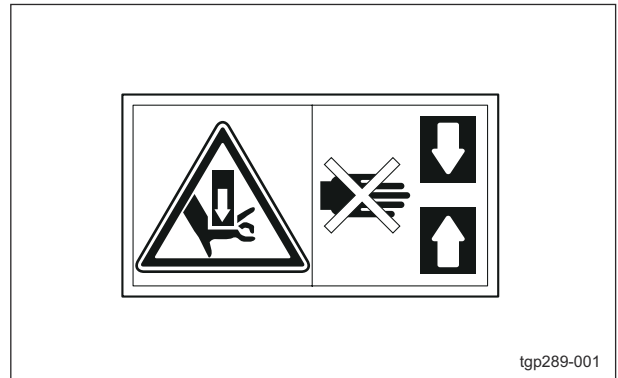

Caution for Getting Caught Decal_001

Caution for High Temperatures Decal

K4205001920
Decal, caution for high temperatures

Caution

High temperature - Do not touch. Otherwise, you will get burned.



Caution for High Temperatures Decal_001

Caution to Rotating Object Decal

K4205001530
Decal, caution to rotating object

Warning

Watch for rotating parts - Keep your hands away from the belts while the engine is running.

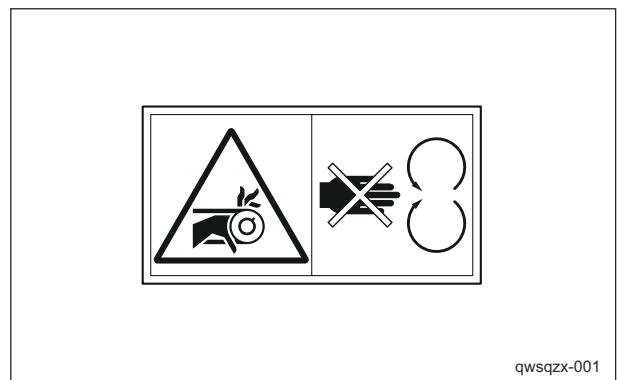

Caution to Rotating Object Decal_001

Hydraulic Oil Decal

K4209001390
 Decal, hydraulic oil
 Read the owner's operating manual.

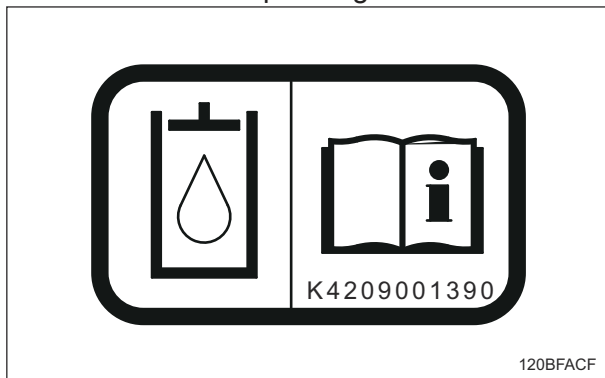

Hydraulic Oil Decal_001

Diesel Fuel Filler Port Decal

K4209001000
 DECAL, DIESEL OIL FILLER PORT
 Use diesel fuel.

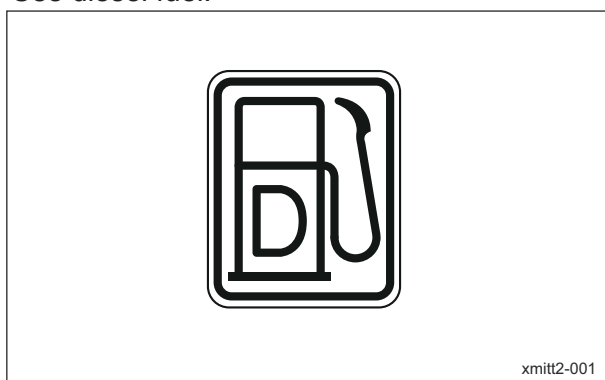

Diesel Fuel Filler Port Decal_001

Fire Prohibited Decal

K4205001940
 Decal, fire prohibited

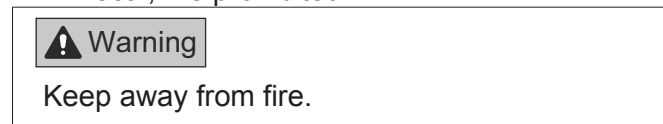

Fire Prohibited Decal_001

Caution for Mower Lock Decal

K4205001900
 Decal, caution for mower lock
 Lock the mower decks when traveling or
 storing with the mower decks #4 and 5 raised.



Caution for Mower Lock Decal_001

Product Overview

Caution for Spouting Coolant Decal

K4205001970
Decal, caution for spouting coolant

Caution

Caution for spouting coolant - Do not open while hot.
High temperature - Do not touch. Otherwise, you will get burned.

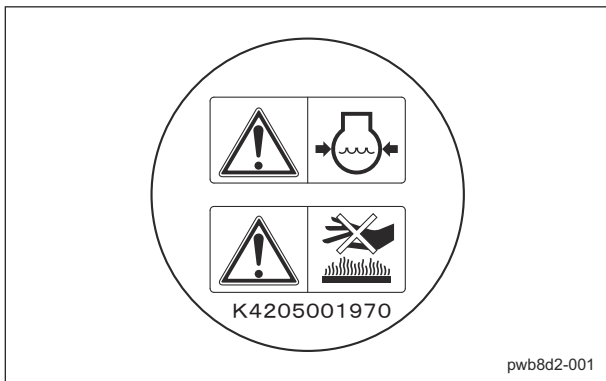

Caution for Spouting Coolant Decal_001

Caution for Getting Pinched Decal

K4205001930
DECAL, CAUTION GETTING CAUGHT HANDS/FEET

Caution

May get pinched - There is a risk of being pinched.

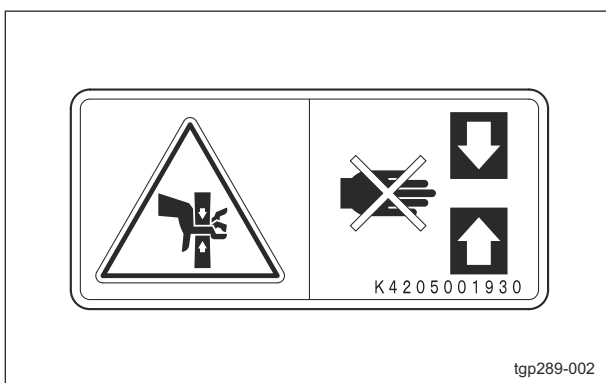

Caution for Getting Pinched Decal_001

Caution to Thrown Object Decal

K4205001650
DECAL, SCATTERING OBJECT

Caution

Thrown objects - Be sure that people around the machine keep a safe distance away.

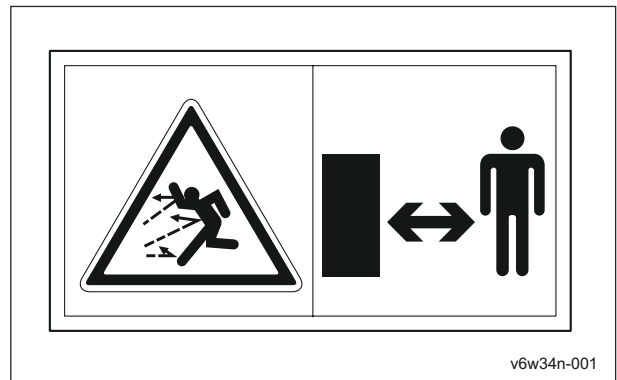

Caution to Thrown Object Decal_001

Caution for Hand or Leg Injury Decal

K4205001780
Decal, caution for hand or leg injury

Warning

May cut your hand or leg - When the blades are rotating, keep away from the machine.

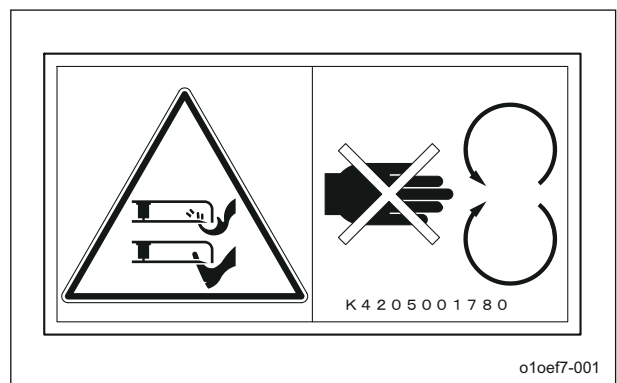

Caution for Hand or Leg Injury Decal_001

Caution Exhaust Gas Decal

K4205001950
Decal, caution exhaust gas

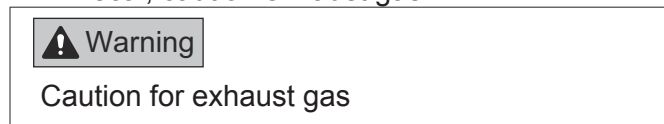

Caution Exhaust Gas Decal_001

Caution to Noise Decal

K4205002090
Decal, caution to noise



Caution to Noise Decal_001

2WD/4WD Selector Important Decal

K4205002330
DECAL, IMPORTANT 2WD/4WD SELECTOR

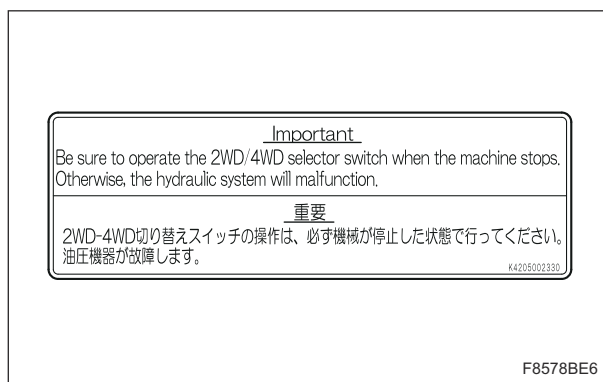
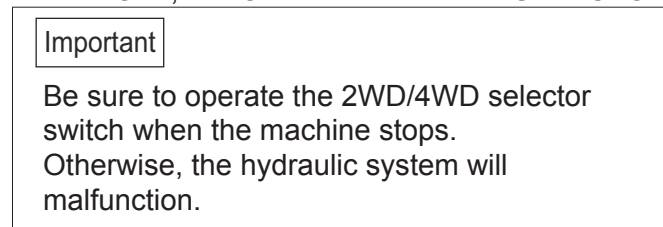

2WD/4WD Selector Important Decal_001

Product Overview

Maintenance Decal

K4209001910

Maintenance decal

The maintenance decal indicates the necessary inspection and maintenance items for this machine.

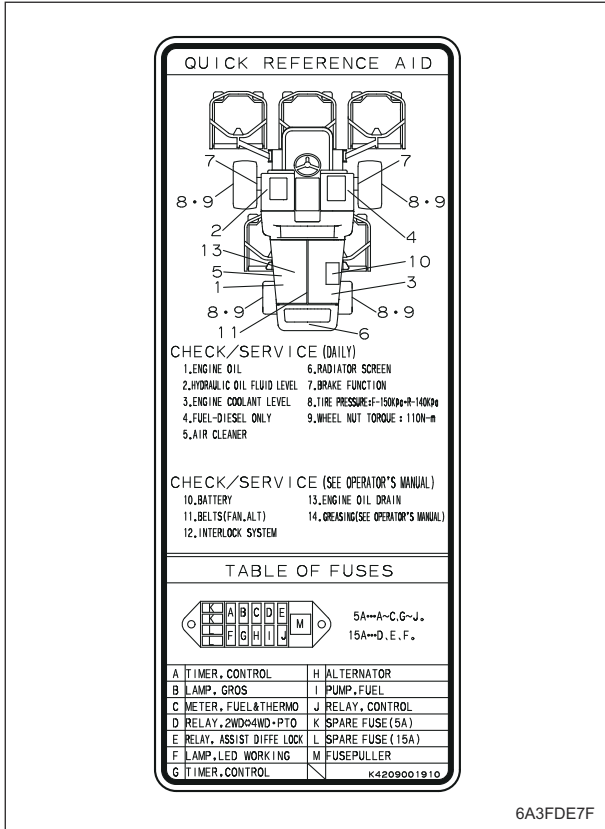

Maintenance Decal_001

Operation Decals

Positions of Operation Decals

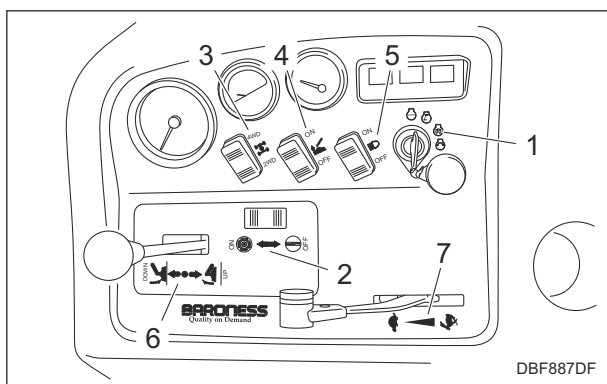

Positions of Operation Decals_001

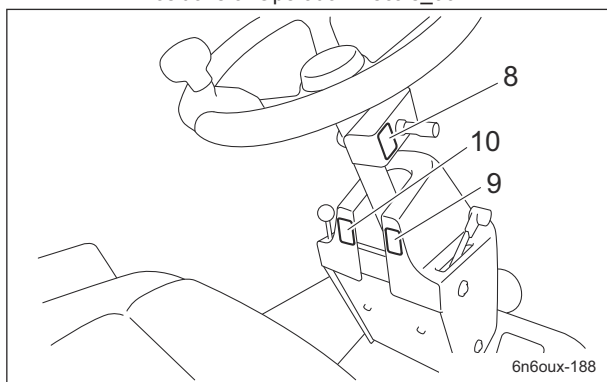

Positions of Operation Decals_002

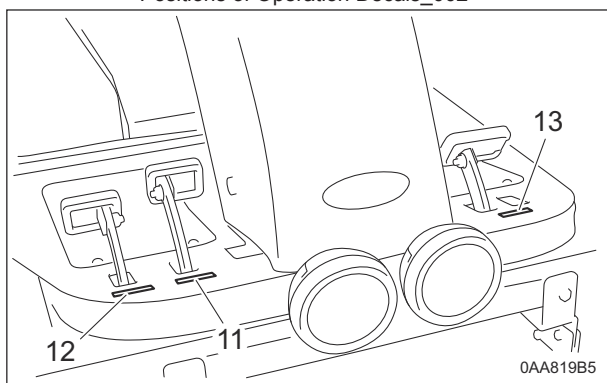

Positions of Operation Decals_003

1	Key switch mark
2	Knife rotation mark
3	2WD/4WD selector mark
4	Traction assist mark
5	Light switch mark
6	Mower deck up/down mark
7	Engine rotation mark
8	Differential lock mark
9	Tilt steering mark
10	Parking brake mark
11	FORWARD decal
12	BACKWARD decal
13	BRAKE decal

Description of Operation Decals

Key Switch Mark

Key switch mark

This indicates the key switch positions.

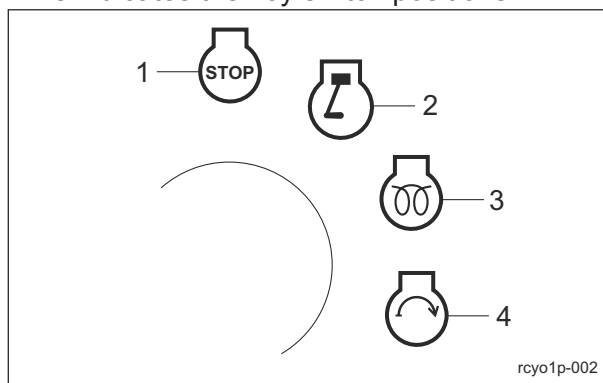

Key Switch Mark_001

1	OFF
2	ON
3	GLOW
4	START

Product Overview

Knife Rotation Mark

Knife rotation mark
It illustrates Rotation/Stop of the rotary knife.

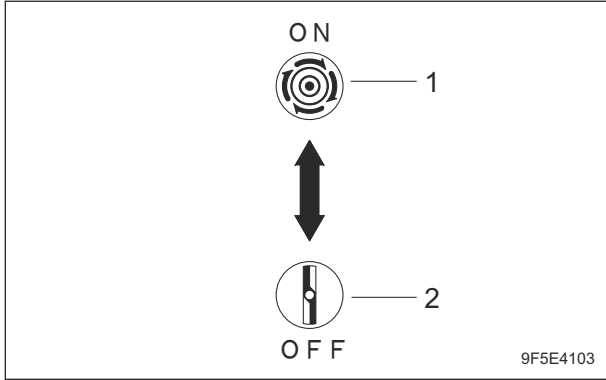

Knife Rotation Mark_001

1	Rotation
2	Stop

Traction Assist Mark

Traction assist mark
It illustrates Activate/ Deactivate of the traction assist.

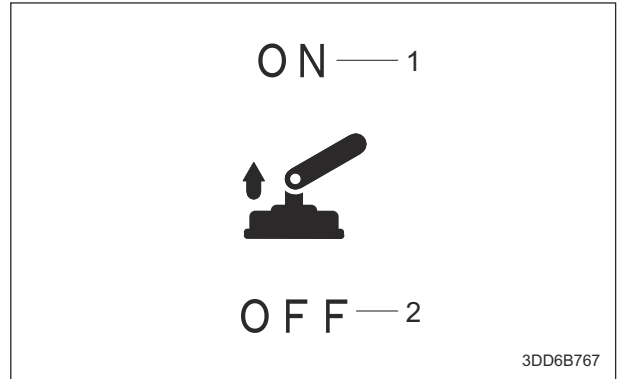

Traction Assist Mark_001

1	Activate
2	Deactivate

2WD/4WD Selector Mark

2WD/4WD selector mark
This indicates 2WD/4WD selections

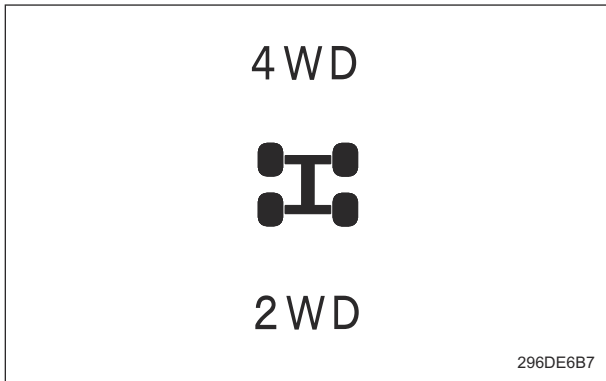

2WD/4WD Selector Mark_001

Light Switch Mark

Light switch mark
It illustrates ON/OFF of the light.

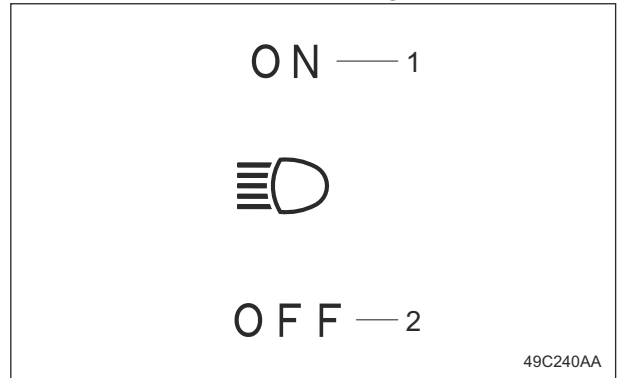

Light Switch Mark_001

1	ON
2	OFF

Product Overview

Mower Deck Up/Down Mark

Mower deck up/down mark
This indicates the Up/Down positions of the mower deck.

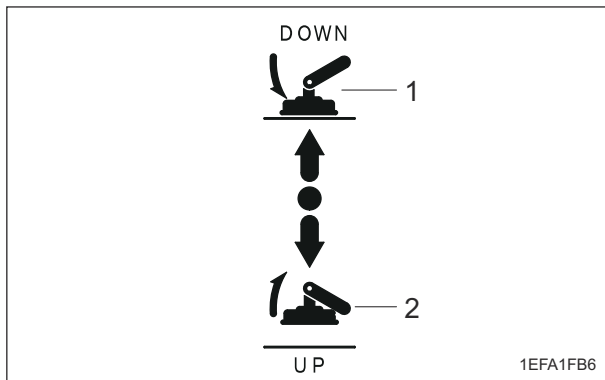

Mower Deck Up/Down Mark_001

1	Down
2	Up

Engine Rotation Mark

Engine rotation mark
This indicates high/low speed of the engine rotation.

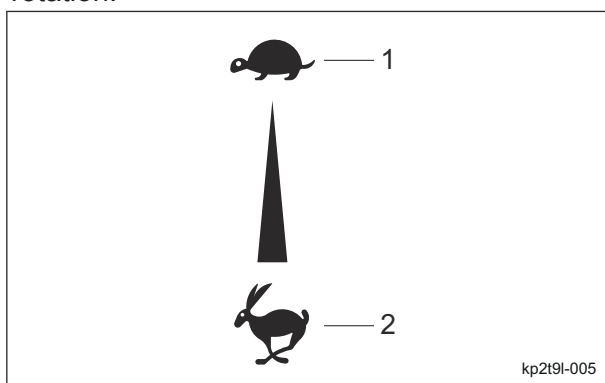

Engine Rotation Mark_001

1	Low speed
2	High speed

Differential Lock Decal

K4203001420
Decal, differential lock
This indicates the positions for engaging or releasing the differential lock.

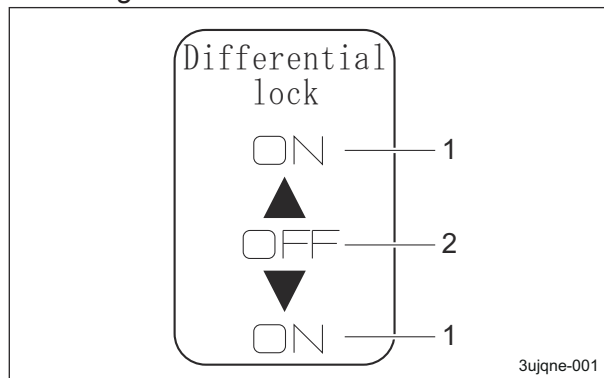

Differential Lock Decal_001

1	Engage
2	Release

Tilt Steering Decal

K4203001350
Decal, tilt steering
This illustrates the tilt directions of the steering wheel and the locked/free positions.

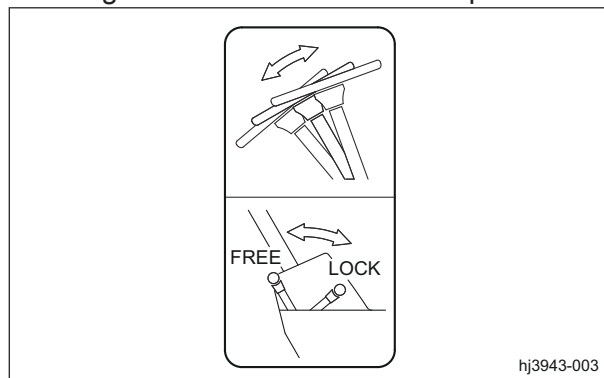

Tilt Steering Decal_001

Product Overview

Parking Brake Decal

K4203001340

Parking brake decal

This shows how to lock and release the parking brake.

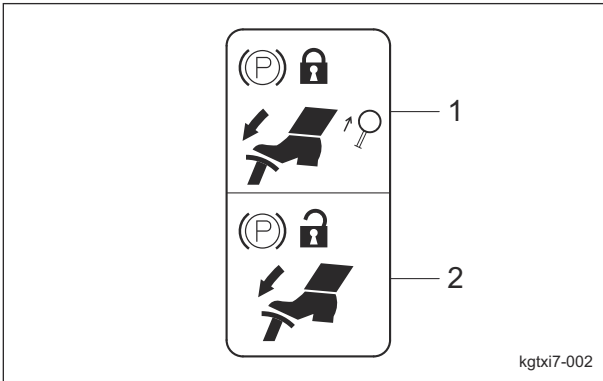

Parking Brake Decal_001

1	Lock
2	Release

FORWARD Decal

K4203001430

Decal, FORWARD

This indicates forward travel.



FORWARD Decal_001

BACKWARD Decal

K4203001440

Decal, BACKWARD

This indicates backward travel.

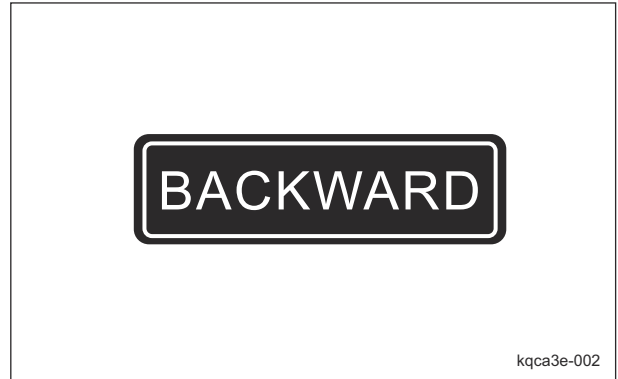

BACKWARD Decal_001

BRAKE Decal

K4203001450

Decal, BRAKE

This indicates brake.



BRAKE Decal_001

Description of Functions

Proximity Sensors	Page 4-2
Relays	Page 4-2
Key Switch	Page 4-2
Knife Rotation Switch	Page 4-3
2WD/4WD Selector Switch	Page 4-3
Light Switch	Page 4-3
Traction Assist Switch	Page 4-4
Mower Lock Lever (Latch)	Page 4-4
Mower Deck Up/Down Lever	Page 4-4
Throttle Lever	Page 4-5
Diff-Lock Switch	Page 4-5
Traveling Pedal	Page 4-6
Brake Pedal	Page 4-6
Change of Braking Method	Page 4-7
Parking Brake Lever	Page 4-7
Instruments on the Operation Panel	Page 4-7
Tachometer/Hour Meter	Page 4-8
Water Temperature Gauge	Page 4-8
Fuel Gauge	Page 4-8
Pilot Lamps	Page 4-9
Safety Device	Page 4-9
Interlock System	Page 4-9
Warning Mechanisms	Page 4-10
Warning Buzzer	Page 4-10

Description of Functions

Proximity Sensors

There are two proximity sensors on mower arm fulcrums #4 and #5. These sensors detect the raised or lowered positions of mower decks #4 and #5. The information is related to controlling rotation and stop of the rotary knives.

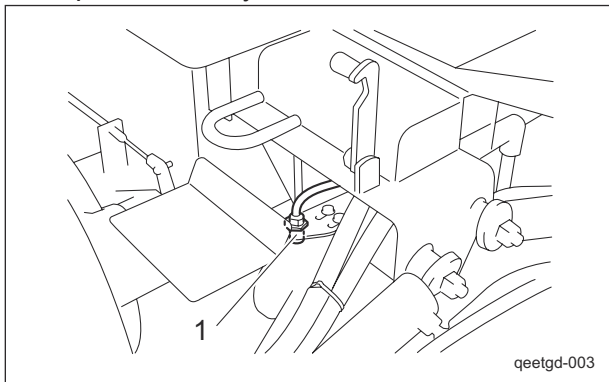

Proximity Sensors_001

1	Proximity sensors
---	-------------------

Relays

The relay box is at the front of the right hood. These relays control operation of the diff-lock valve, rotation of the rotary knives, 2WD/4WD selection and traction assist selection. The operating condition can be checked by the illumination of the LEDs.

- LEDs ①, ② and ③ light up when the diff-lock valve is in the "ON" position.
- LED ④ lights up when the traction assist switch is in the "ON" position.
- LEDs ⑤ and ⑥ light up when the knife rotation switch is in the "ON" position and the mower deck is lowered.
- LEDs ⑦ and ⑧ light up when the 2WD/4WD selector switch is in the "4WD" position, and then the machine enters 4WD.

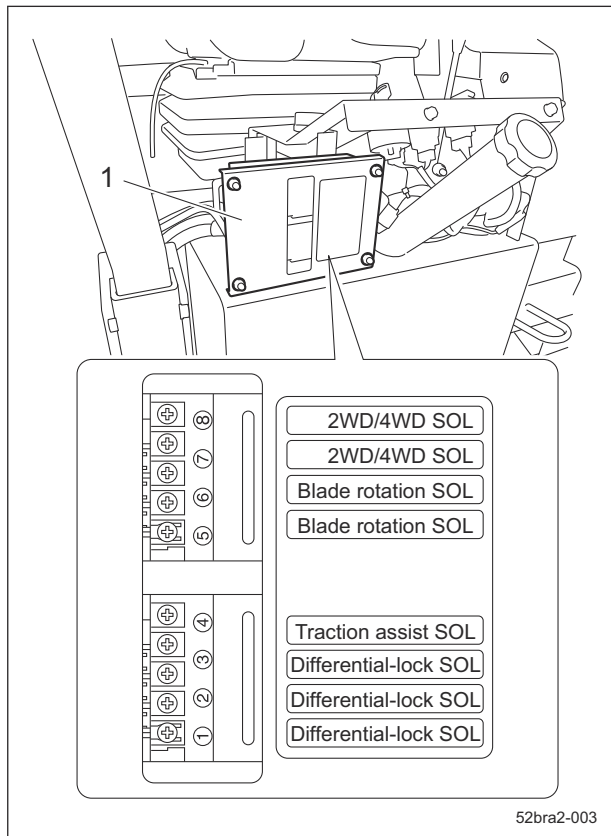

Relays_001

1	Relay box
---	-----------

Key Switch

The key switch is a lock for inserting the ignition key. This is used to start, run or stop the engine by turning the ignition key to change the key switch position.

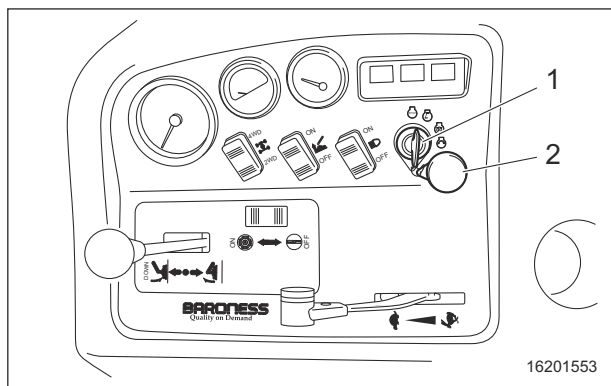

Key Switch_001

1	Key switch
2	Cap

Description of Functions

Knife Rotation Switch

Caution

Before you start cutting work, set the knife rotation switch to the "Rotation" position. At all other times, make sure it is set to the "Stop" position.

Important

Be sure to switch when the machine stops. Otherwise, the hydraulic system will malfunction.

The knife rotation switch is located in the operation panel and controls the rotation of the rotary knives in the mower decks. When the knife rotation switch is set to the "Rotation" position, the rotary knife in all mower decks rotates. When the knife rotation switch is set to the "Stop" position, the rotary knives stop.

Note:
When the mower decks are raised, the rotary knives do not rotate, even if the switch is set to the "Rotation" position.

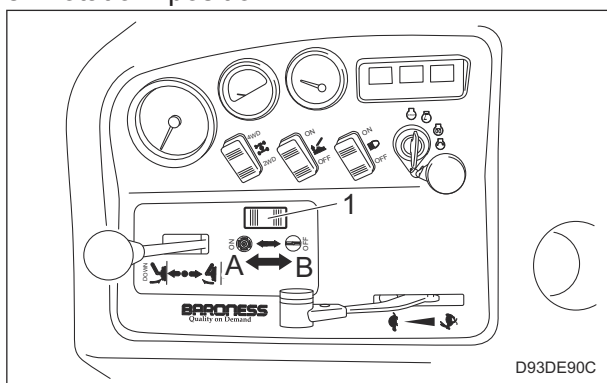

Knife Rotation Switch_001

1	Knife rotation switch
A	Rotation
B	Stop

2WD/4WD Selector Switch

Caution

When working on a slope, be sure to use the machine in 4WD.

Caution

When traveling, be sure to stop the knives and raise the mower decks.

Important

Be sure to switch when the machine stops. Otherwise, the hydraulic system will malfunction.

The 2WD/4WD selector switch is located in the operation panel. When the switch is set to the "2WD" position, the machine will be in two-wheel drive (front-wheel drive). When it is set to the "4WD" position, the machine will be in four-wheel drive.

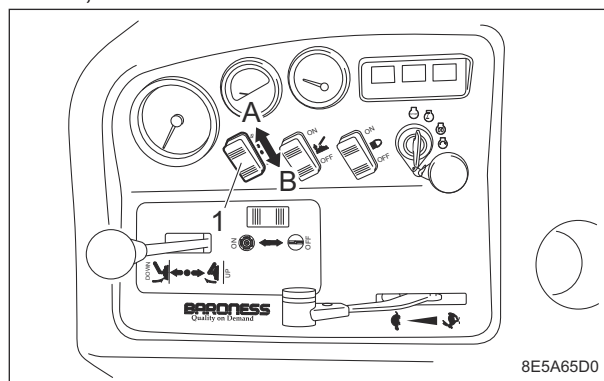

2WD/4WD Selector Switch_001

1	2WD/4WD selector switch
A	4WD
B	2WD

Light Switch

Caution

The lights provide auxiliary lighting. Do not travel or operate the machine at night or under poor visibility.

The light switch is located in the operation panel. When the switch is set to the "ON" position, the lights turn on. When it is set to the "OFF" position, the lights turn off.

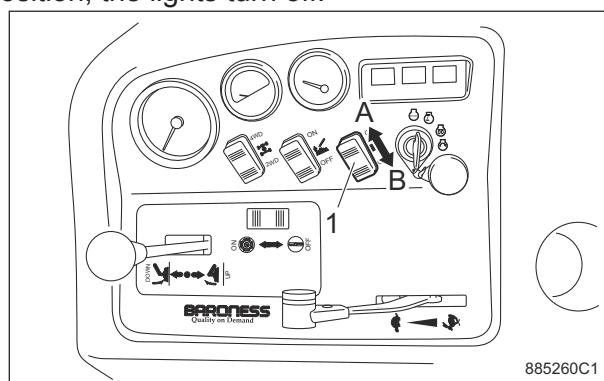

Light Switch_001

Description of Functions

1	Light switch
A	ON
B	OFF

Traction Assist Switch

The traction assist switch is located in the operation panel.

This switch is effective to increase climbing ability when this machine is in cutting operation (4WD).

- The cylinders are pressurized even with the switch set to the "OFF" position and so the mower decks are a little raised.
- When the switch is set to the "ON" position, the traction assist mode is automatically switched and the power lifting the mower decks and climbing ability are increased.
- When the switch is set to the "ON" position and the machine is in cutting operation on a slope of 13 degrees or more, the power lifting the mower decks and climbing ability are further increased.

Note:

Tracking may be impaired if the machine is used with the switch set to the "ON" position in an area with many undulations.

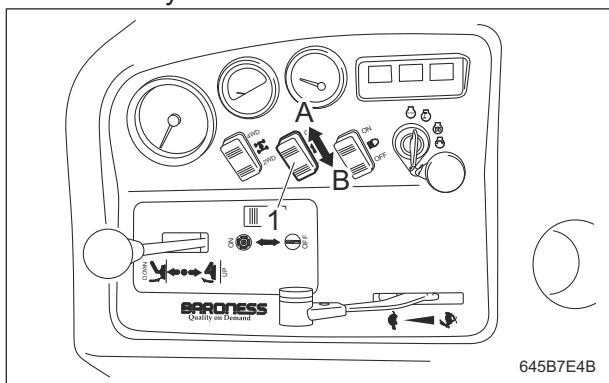

Traction Assist Switch_001

1	Traction assist switch
A	ON
B	OFF

Mower Lock Lever (Latch)

The mower lock levers (latches) are located in the foot area on the left and right sides.

Hook the mower lock levers (latches) on the arms to keep the mower decks #4 and #5 raised.

The mower lock levers (latches) may be used for the following operations.

- Moving by the machine
- Transporting the machine
- Storing the machine

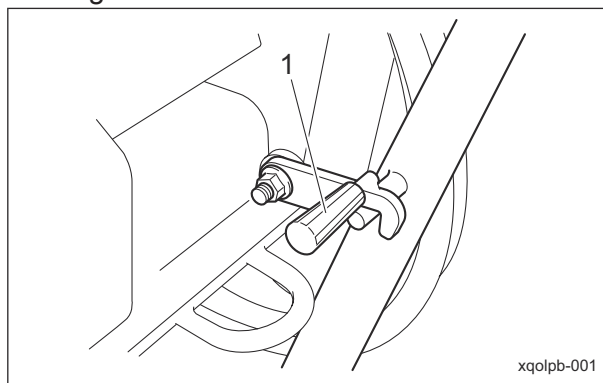

Mower Lock Lever (Latch)_001

1	Mower lock lever (latch)
---	--------------------------

Mower Deck Up/Down Lever

Caution

Before raising or lowering the mower decks, make sure that there are no people around the machine.

Important

When the mower lock levers (latches) are engaged, do not operate the mower deck up/down lever.

The mower deck up/down lever is located in the operation panel and raises or lowers the mower decks.

When the lever is shifted to the "Lower" position, the mower decks are lowered. When the lever is shifted to the "Raise" position, the mower decks are raised.

Release the lever to return it to the neutral position.

Description of Functions

Note:
When the mower decks are raised, the rotary knives stop rotating, even if the knife rotation switch is set to the "Rotation" position.

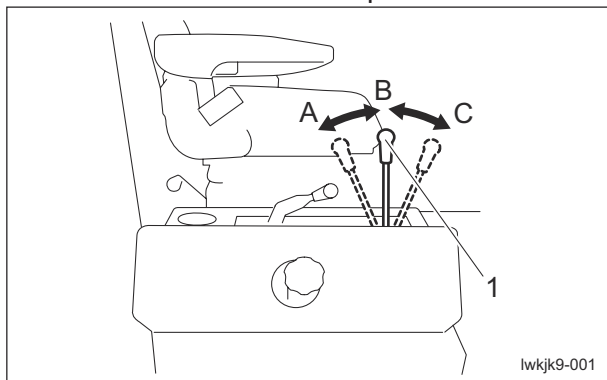

Mower Deck Up/Down Lever_001

1	Mower deck up/down lever
A	Raise
B	Neutral
C	Lower

The diff-lock switch is located below the right side of the steering wheel and engages the differential lock for the left and right front wheels. Tilt the switch lever up or down to turn "ON" to engage the differential lock for the front wheels. Release the switch lever to return it to the neutral position ("OFF" position) and disengage the differential lock.

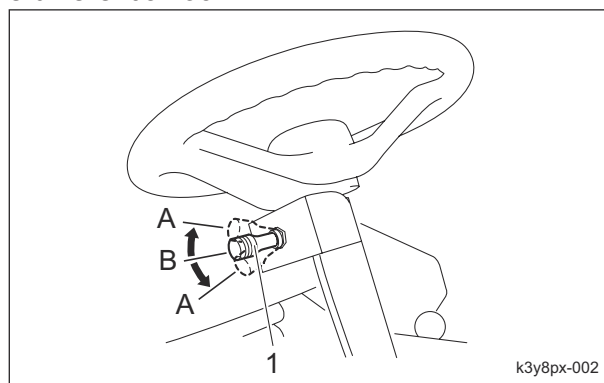

Diff-Lock Switch_001

1	Diff-lock switch
A	ON (Lock)
B	OFF (Release)

Throttle Lever

The throttle lever is located to the right of the driver's seat and enables you to adjust the engine rpm. Move the throttle lever toward the "High speed" position to increase the engine rpm, and toward the "Low speed" position to reduce the rpm.

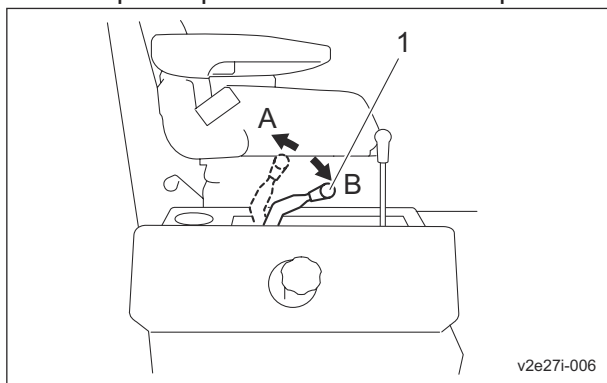

Throttle Lever_001

1	Throttle lever
A	High speed
B	Low speed

Diff-Lock Switch

Important

Do not operate the diff-lock switch unless it is necessary.

Description of Functions

Traveling Pedal

Caution

When the machine is traveling at a high speed, it will not stop immediately after you take your foot off the traveling pedal.

The traveling pedals are located in the right foot area and control forward and reverse operation of the machine.

When the forward pedal (inside) is depressed, the machine travels forward. When the reverse pedal (outside) is depressed, the machine travels in reverse.

The speed changes in accordance with how much the pedal is depressed.

When you take your foot off the pedal, the machine stops automatically.

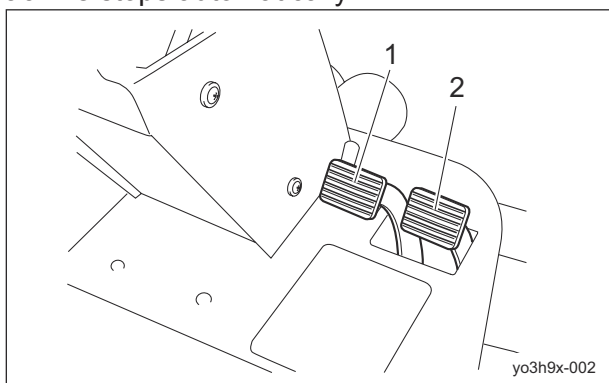

Traveling Pedal_001

1	Forward pedal
2	Reverse pedal

Brake Pedal

Warning

Link the brake pedals, except when operating the machine.

Using the brake pedals without linking them may result in the machine overturning.

Important

When depressing the brake pedals to make turns with a small radius, obtain a sufficient awareness of the lawn and ground conditions. This will damage the lawn.

The brake pedals are located in the left foot area and operate the left and right brakes independently.

By depressing the brake pedal on the side in which the turn will be made, the machine can make turns with a small radius.

If the front wheel on the upward side of a slope slips, depress the brake pedal for the wheel on the upward side in order to increase the traction of the wheel on the downward side and stabilize travel.

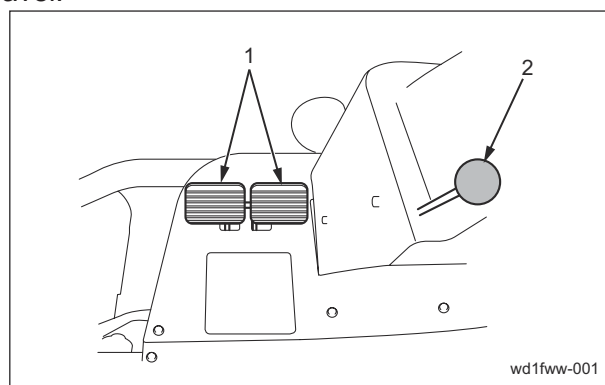

Brake Pedal_001

1	Brake pedals
2	Parking brake lever

Description of Functions

Change of Braking Method

Follow the procedure below to change the braking method from linked to independent.

1. Swing up the pedal link bar, and then pull it out from the right brake pedal.

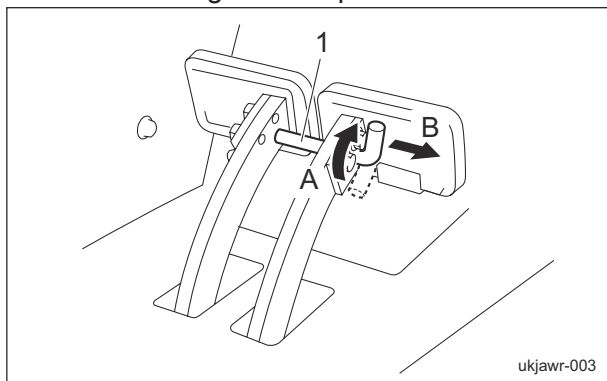

Change of Braking Method_001

1	Pedal link bar
A	Swing up
B	Pull out

2. Secure the pedal link bar in the holder on the left brake pedal.

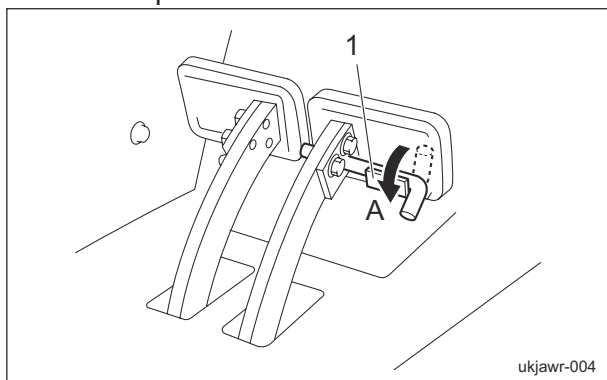

Change of Braking Method_002

1	Holder
A	Secure

Parking Brake Lever

Caution

Never park the machine on a slope.

Important

Be sure to release the parking brake before driving. It may result in the brakes or hydraulic system malfunction.

The parking brake lever is located to the left of the front cover. When parking, link the left and right brake pedals by using the pedal link bar, depress both brake pedals, and then pull the parking brake lever completely. To release the parking brake, depress the brake pedals.

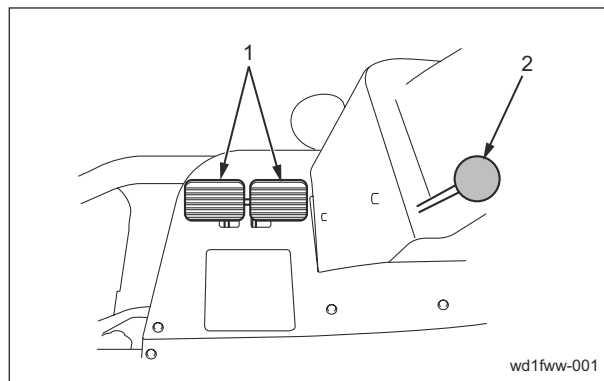

Parking Brake Lever_001

1	Brake pedals
2	Parking brake lever

Instruments on the Operation Panel

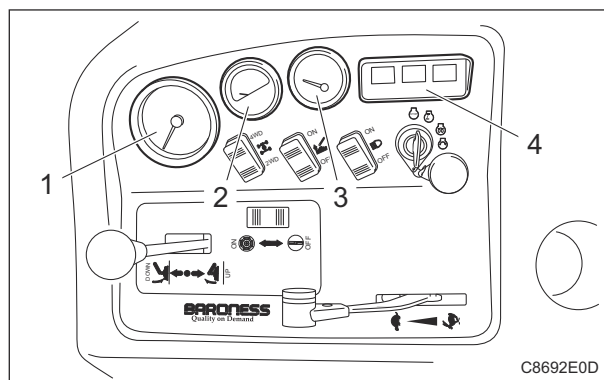

Instruments on the Operation Panel_001

Description of Functions

1	Tachometer/Hour meter
2	Water temperature gauge
3	Fuel gauge
4	Pilot lamps (charge lamp, thermo-start lamp, oil pressure lamp)

Tachometer/Hour Meter

The tachometer and hour meter are located in the operation panel.

1. Tachometer

The tachometer indicates the engine rpm.

2. Hour Meter

The hour meter indicates total operation time of the engine.

Every six minutes of engine operation will increase the number at the first digit by one. Every one hour of engine operation will increase the number at the next digit by one. Indication range : 99999.9 (minimum 0.1) 1/10 hour is indicated in the first decimal place. An hour is indicated as an integral number.

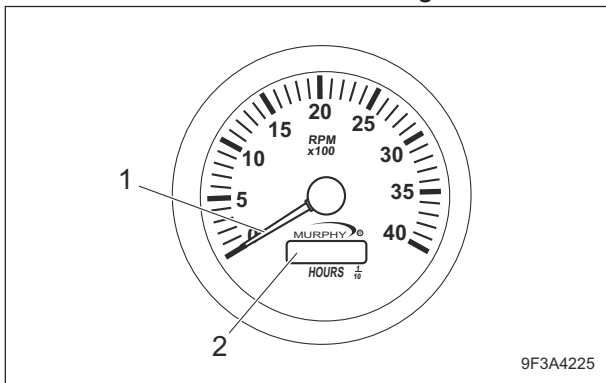

Tachometer/Hour Meter_001

1	Tachometer
2	Hour meter

Water Temperature Gauge

The water temperature gauge is located in the operation panel.

This instrument indicates the water temperature inside the engine.

If the water temperature gauge indicates a level close to "H" during operation, the machine is overheated.

Remove the load from the engine, idle the machine for five minutes, stop the engine, and then inspect the machine and perform any necessary maintenance.

If the water temperature exceeds 115 °C (239 °F), a buzzer will sound. (intermittent tone)

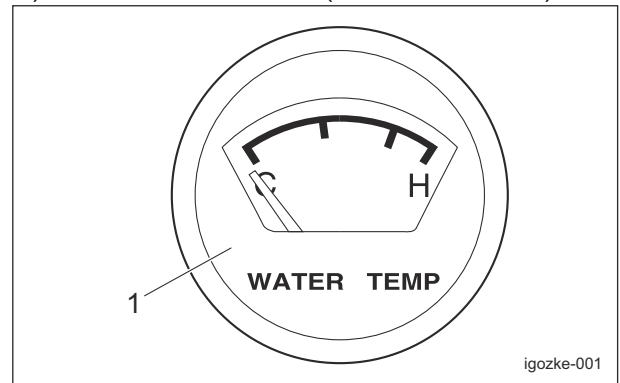

Water Temperature Gauge_001

1	Water temperature gauge
---	-------------------------

Fuel Gauge

The fuel gauge is located in the operation panel.

This instrument indicates the quantity of fuel inside the fuel tank.

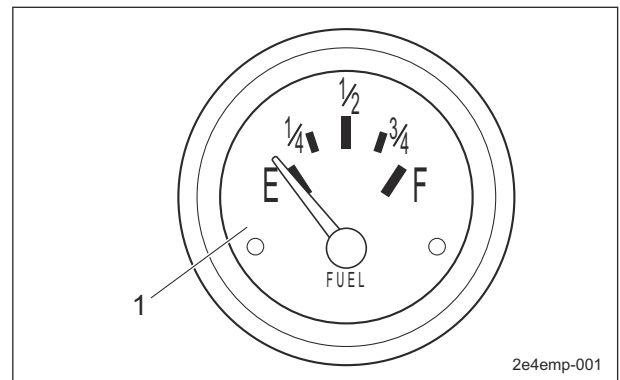

Fuel Gauge_001

1	Fuel gauge
---	------------

Description of Functions

Pilot Lamps

1	Thermo-start lamp
---	-------------------

Charge Lamp

The charge lamp is the left pilot lamp located in the operation panel.

It turns on when the ignition key is set to the "ON" position before the engine starts. It turns off when the engine starts and the alternator starts operating properly.

If this lamp illuminates while you are operating the machine, stop the engine immediately, and then inspect the machine and perform any necessary maintenance.

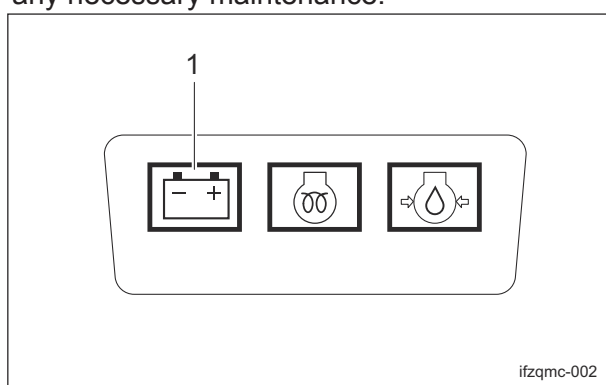

Charge Lamp_001

1	Charge lamp
---	-------------

Oil Pressure Lamp

The oil pressure lamp is the right pilot lamp located in the operation panel.

It turns on when the ignition key is set to the "ON" position before the engine starts. It turns off when the engine starts and engine oil pressure is generated properly.

If this lamp illuminates while you are operating the machine, stop the engine immediately, and then inspect the machine and perform any necessary maintenance.

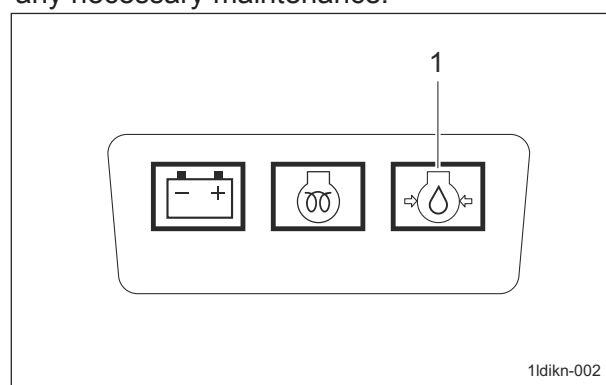

Oil Pressure Lamp_001

1	Oil pressure lamp
---	-------------------

Thermo-Start Lamp

The thermo-start lamp is the middle pilot lamp located in the operation panel.

When the ignition key is set to the "GLOW" position, it illuminates as the glow plug generates heat.

Illumination of the thermo-start lamp is controlled by the glow lamp timer, and the lamp is turned off after a specified amount of time passes.

The duration of illumination indicates an approximate period of time required for warm-up, and has been fixed at five seconds.

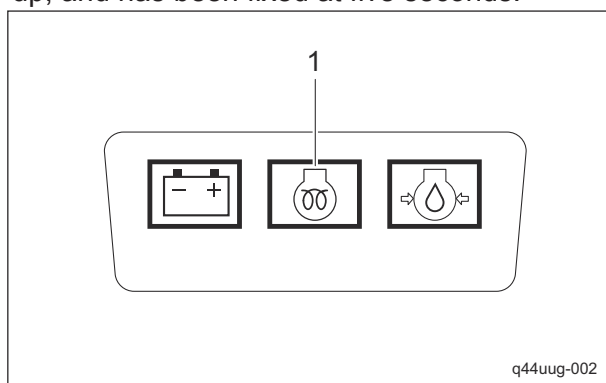

Thermo-Start Lamp_001

Safety Device

Interlock System

This machine features a safety device for starting/stopping the engine.

- As for starting the engine, the safety device prevents the engine from starting unless it meets each of the following four conditions.
 - An operator is sitting on the seat.
 - The parking brake is applied.
 - The knife rotation switch is set to the "Stop" position.
 - The traveling pedal is set to the neutral position.
- If the operator leaves the seat with the parking brake not applied and the engine running, the safety device will be activated and will stop the engine.

Description of Functions

3. If the operator leaves the seat with the parking brake applied and the engine running, the safety device will be activated and will stop the engine under any of the following conditions:
 - The traveling pedal is not set to the neutral position. (The operator has depressed the traveling pedal.)
 - The knife rotation switch is set to the "Rotation" position.

Warning Mechanisms

Warning Buzzer

Important

When the buzzer (intermittent tone) sounds, be sure to stop operation since the engine is overheated.

Do not stop the engine without idling. Allow the engine to cool down, first. Keep the engine idling for about 5 minutes before stopping. Remove dust that is jamming in the radiator, air cleaner, and etc.

This machine features warning mechanisms for overheating and for the hydraulic oil level.

1. Overheat warning buzzer

If the engine water temperature exceeds 115 °C (239 °F), a buzzer will sound. (intermittent tone)

When the warning buzzer sounds, stop the engine immediately after idling, and then inspect the machine and perform any necessary maintenance.

2. Hydraulic oil level warning buzzer

If the oil level in the hydraulic tank declines from the specified level by approximately 2.0 dm³ (2.0 L), a buzzer will sound. (continuous tone)

When the warning buzzer sounds, stop the engine immediately, and then inspect the machine and perform any necessary maintenance.

Operations before Service Page 5-2

Procedure to Open/Close Hood Page 5-2

Procedure to Open/Close Underseat
Cover Page 5-3

Inspection before Use Page 5-3

EnginePage 5-3

Main Vehicle Page 5-6

Mower DeckPage 5-9

Adjustment before Work Page 5-10

Main Vehicle Page 5-10

Start/Stop of Engine Page 5-11

Procedure to Start EnginePage 5-11

Procedure to Stop Engine Page 5-12

Parking and StoppingPage 5-13

Procedure to Leave The Machine Page 5-13

MovePage 5-13

Traveling Procedure Page 5-13

Cutting Work Page 5-13

Cutting ProcedurePage 5-13

TransportingPage 5-14

Transporting Procedure Page 5-14

Cleaning after Use Page 5-14

EnginePage 5-14

Main Vehicle Page 5-15

Mower DeckPage 5-15

Storage Page 5-16

Short-Term Storage Page 5-16

Handling Instructions

Operations before Service

The following sections describe the preparatory works required before performing the services including inspection, adjustment, cleaning, maintenance and repair.

Procedure to Open/Close Hood

Caution
Do not open the hood in strong winds.

Caution
Be careful not to pinch your fingers when you open or close the hood.

1. Procedure to open the hood

[1] Remove the nuts and bolts locking the catch clips on the left and right sides of the hood.

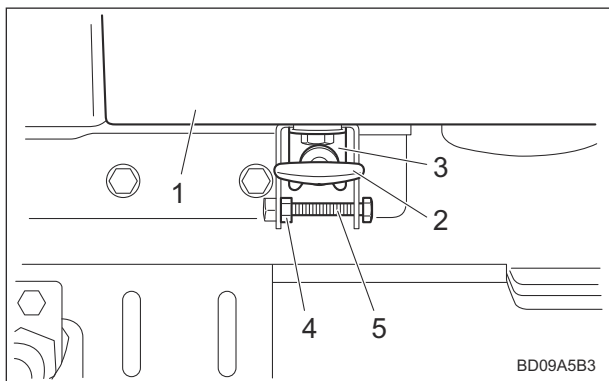

Procedure to Open/Close Hood_001

1	Hood
2	Rubber catch
3	Catch clip
4	Nut
5	Bolt

[2] Release the rubber catches on the left and right sides.

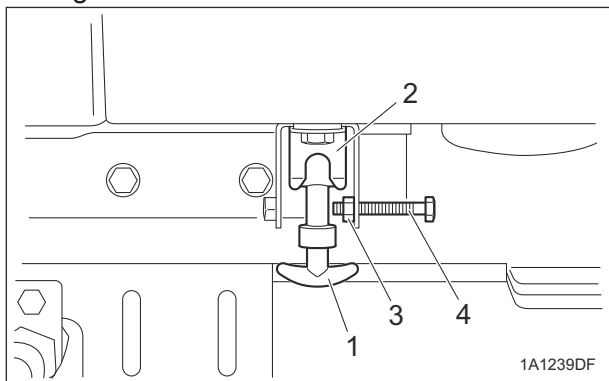

Procedure to Open/Close Hood_002

1	Rubber catch
2	Catch clip
3	Nut
4	Bolt

[3] Lift up the hood.

[4] Hook the hood stay on the receiver inside of the hood cover.

[5] Make sure that the hood is fixed, and then release your hands.

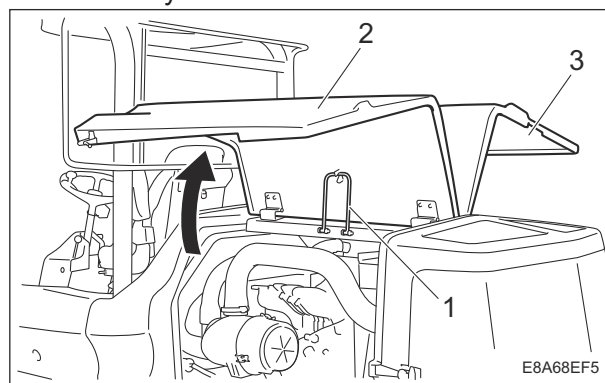

Procedure to Open/Close Hood_003

1	Hood stay
2	Hood cover (LH)
3	Hood cover (RH)

2. Procedure to close the hood

[1] Release the hood stay, and then close the hood slowly.

[2] Securely engage the left and right rubber catches.

[3] Install the nuts and bolts locking the left and right catch clips.

Handling Instructions

Procedure to Open/Close Underseat Cover

⚠ Caution

Be careful not to pinch your fingers when you open or close the underseat cover.

1. Procedure to open the underseat cover
 - [1] Make sure that the steering wheel is raised completely.
 - [2] Bring the seat to the backmost position.
 - [3] Pull up the lever behind the seat to unlock it.
 - [4] Tilt the seat forward to open the cover.

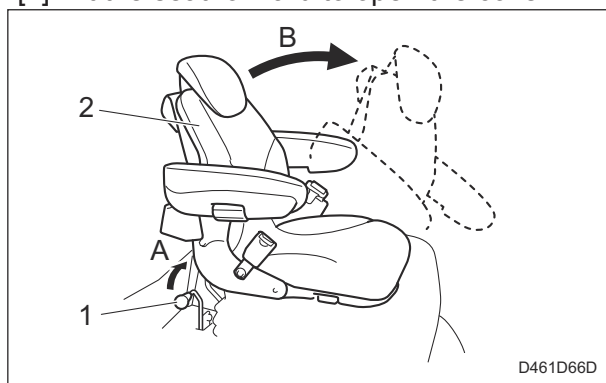

Procedure to Open/Close Underseat Cover_001

1	Lever
2	Seat
A	Pull up
B	Tilt forward

2. Procedure to close the underseat cover
 - [1] Slowly set the seat to its original position, and then slowly close the underseat cover.

Inspection before Use

The purpose of the machine inspection is to:

- Prevent accidents
- Prevent damage to the machine
- Maintain machine performance

Detecting machine malfunctions early helps prevent unexpected problems from occurring. If you detect any abnormalities with the machine, immediately perform maintenance or repairs.

Engine

Inspection of Engine Oil

Important

Securely insert the oil level gauge.

Check the contamination of oil and engine oil level to inspect the engine oil. Inspect the engine oil level 10 to 20 minutes after stopping the engine.

1. Place the machine so that the engine is level.
2. Stop the engine.
3. Open the hood.
4. Pull out the oil level gauge.

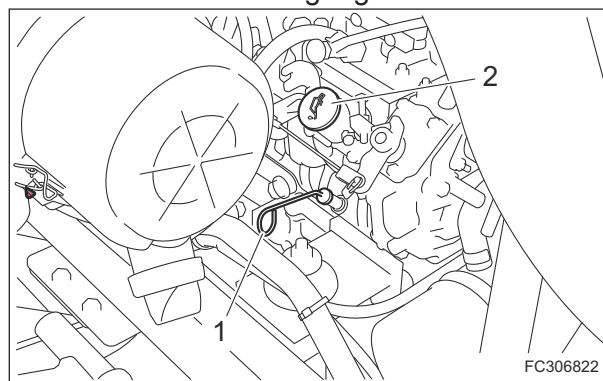

Inspection of Engine Oil_001

1	Oil level gauge
2	Oil filler cap

5. Wipe the oil off the oil level gauge cleanly with papers or cloths.
6. After wiping the oil off the oil level gauge, check the contamination.
7. Return the oil level gauge to its original position, insert tightly, and pull out again.

Handling Instructions

8. Check the engine oil level.

The appropriate oil level should be between the upper and lower limit lines on the gauge.

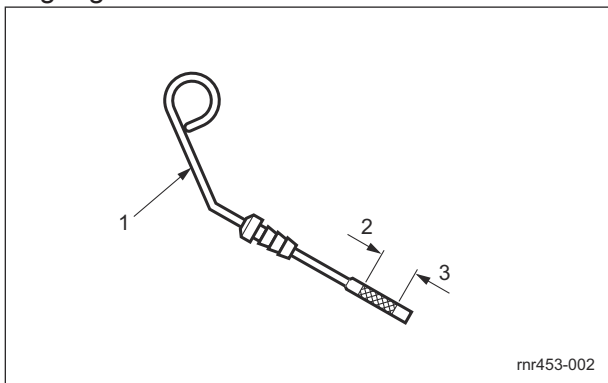

Inspection of Engine Oil_002

1	Oil level gauge
2	Upper limit
3	Lower limit

9. Return the oil level gauge to its original position, and insert it tightly.

10. Close the hood.

Inspection of Fuel Quantity

With the machine on a level surface, observe the fuel gauge in the operation panel to check the fuel level.

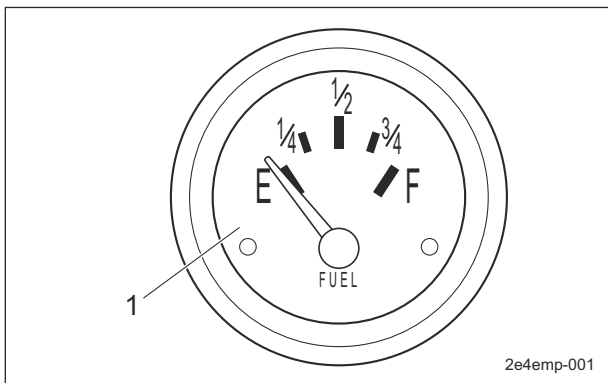

Inspection of Fuel Quantity_001

1	Fuel gauge
---	------------

Supply of Fuel

Warning

Do not supply fuel above F (FULL) level of the fuel gauge.
If you supply too much fuel, it might overflow from the fuel cap when you travel or work on a slope.

Warning

Keep fire away while refueling.
Do not smoke while refueling.

Warning

Supply fuel after the engine is stopped and has well cooled down.

If the fuel gauge located in the operation panel indicates a level close to E (EMPTY), supply fuel (diesel) at your earliest convenience.

The fuel tank capacity is approximately 51.0 dm³ (51.0 L).

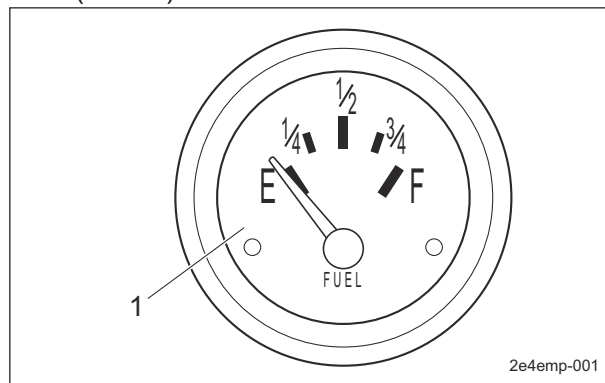

Supply of Fuel_001

1	Fuel gauge
---	------------

Handling Instructions

Air Bleeding of Fuel System

Important

The air-bleed plug should always be in the closed position except during the air bleeding operation.

Using the machine with the air-bleed plug in the open position may cause the engine to stall.

Air bleeding is not a required operation for this machine since it occurs automatically.

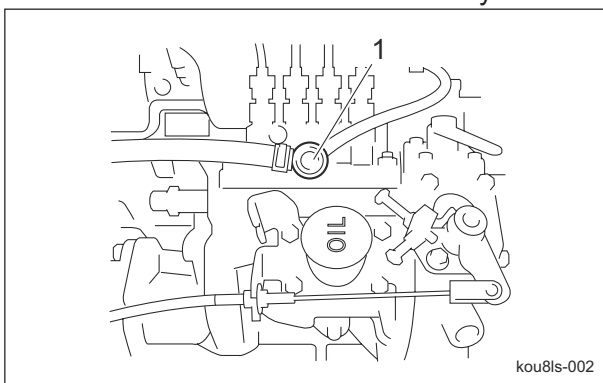

Air Bleeding of Fuel System_001

1	Air-bleed plug
---	----------------

Inspection of Fuel Filter

1. Make sure that there is no fuel leakage.
2. Make sure that the filter is not damaged.
3. Make sure that the filter is not contaminated.

Inspection of Coolant

⚠ Caution

Do not touch the radiator or coolant during engine operation or immediately after the engine has been turned off. Otherwise, you may get burned.

⚠ Caution

Inspection should take place after the engine has well cooled down.

Make sure that the coolant level in the reserve tank is between "FULL" and "LOW".

If the coolant level is lower than the "LOW" mark, supply clean water and antifreeze.

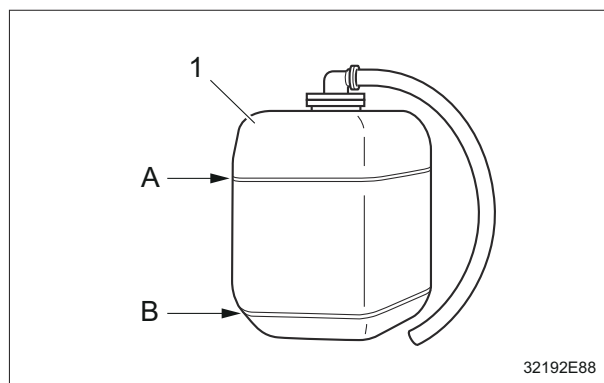

Inspection of Coolant_001

1	Reserve tank
A	Full
B	Low

Inspection of Air Cleaner

1. Make sure that there is no damage to the air cleaner.
2. Make sure that the air cleaner is not contaminated.
Check the vacuum indicator for contamination in the air cleaner. If the air cleaner element is contaminated, the vacuum indicator will display a red ring.

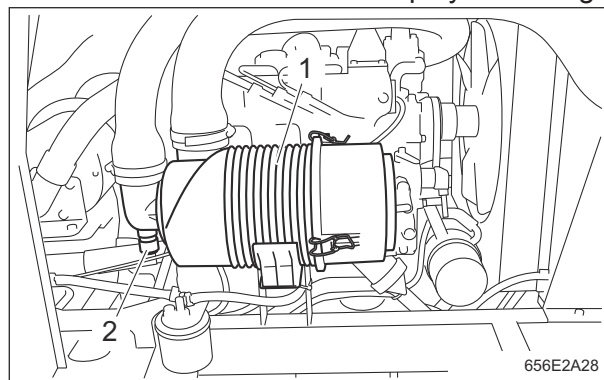

Inspection of Air Cleaner_001

1	Air cleaner
2	Vacuum indicator

Handling Instructions

Inspection of Radiator Cover

1. Make sure that there is no damage to the radiator cover.
2. Make sure that the radiator cover is not contaminated.

Inspection of Radiator

1. Make sure that there is no damage to the radiator.
2. Make sure that the radiator is not contaminated.

Inspection of Engine-Associated Parts

Caution

Perform operations after the muffler, engine and other parts have sufficiently cooled. Otherwise, you may get burned.

1. Check for damages and dirt.
2. Check the mount for looseness and cracks.
3. Check for liquid leakage.
4. Check on and around the muffler for grass clippings and flammable materials.

Main Vehicle

Inspection of Hydraulic Oil

The oil gauge is on the side of the hydraulic tank.

1. Lower the mower decks and maintain that position on a level surface.
2. Make sure that the oil level is at the middle of the oil gauge.

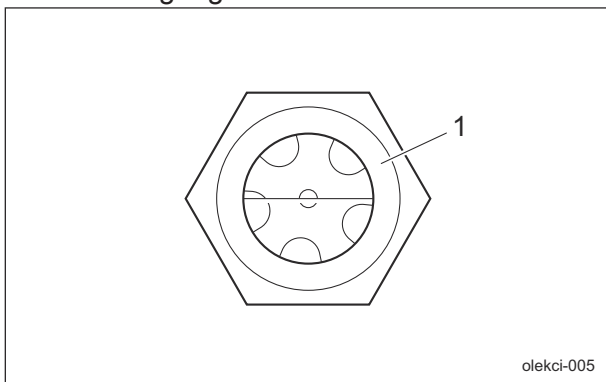

Inspection of Hydraulic Oil_001

1	Oil gauge
---	-----------

3. Check underneath the machine for oil leakage.

Inspection of Tires

1. Check the pneumatic pressure of the tires.
2. Make sure that there are no cracks, damage or abnormal wear.

Tire size	Pneumatic pressure	
Front wheel (29 x 14.00 - 15)	150 kPa (1.5 kgf/cm ²)	22 psi
Rear wheel (20 x 12.00 - 10)	140 kPa (1.4 kgf/cm ²)	20 psi

Inspection of Battery

Danger

Keep away from fire while inspecting or charging the battery. The battery may explode.

Caution

Implement after the engine and muffler etc. have well cooled down. Otherwise, you may get burned.

Important

Be sure to stop the engine before inspecting or charging the battery.

Battery inspection items are described below.

1. Inspecting the exterior
Visually inspect the exterior of the battery, and check that there are no cracks, splits, missing sections, or abnormal deformation in the battery case, and that there is no electrolyte leaking. If abnormalities are found, immediately replace the battery.

Handling Instructions

2. Cleaning the exterior

Warning

Do not clean the battery with a dry cloth. Cleaning the battery with a dry cloth may cause it to catch fire or explode due to static electricity.

Use a wet cloth for cleaning.

Inspect the vent plugs or vent holes on the side of the battery, and if they are blocked by dirt wash them with water to remove the blockage.

Continuing to use the battery with the vent holes blocked may cause the battery to rupture from increased internal pressure due to gases generated inside the battery.

3. Inspecting the mounting bracket

Inspect whether the battery is secured firmly with the mounting bracket.

If the bracket is loose, tighten the mounting bracket nuts until the battery is secured firmly.

An improperly mounted battery may cause damage to the battery case or electrolyte leaks due to the battery moving with vibrations while traveling.

4. Inspecting the cable terminals

If the connection between the battery terminals and vehicle's cable terminals are loose, tighten the nuts until the cable terminals are secured firmly.

Insufficiently tightened terminals may result in poor battery charging, damage to the terminals due to poor contacts, or an explosion.

If the terminals are corroded, rub them clean with a wire brush or fine grit sandpaper, and lightly apply anti-rust grease.

5. Inspecting the electrolyte level and refilling

Warning

Do not allow the battery fluid level to become lower than the LOWER LEVEL (minimum fluid level line).

The battery may explode if it is used or charged while the battery fluid level is at the LOWER LEVEL (minimum fluid level line).

Warning

When refilling, do not fill purified water above the UPPER LEVEL line.

Doing so may result in electrolyte leaks.

Clean the areas around the battery fluid level lines using a cloth damped with water to check the electrolyte level from the side of the battery.

Make sure that the battery fluid level is between the UPPER LEVEL (maximum fluid level line) and the LOWER LEVEL (minimum fluid level line).

Refill with purified water up to the UPPER LEVEL line if the level is lower than halfway between the UPPER LEVEL and LOWER LEVEL lines.

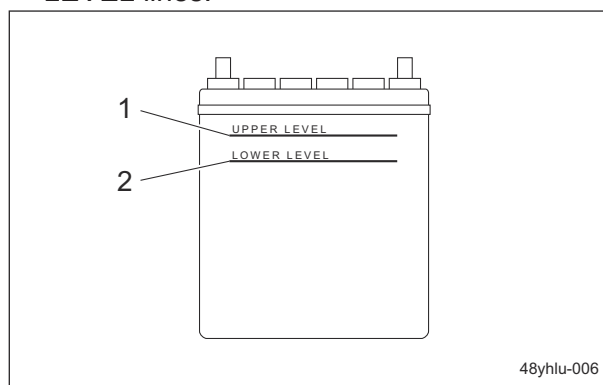

Inspection of Battery_001

1	UPPER LEVEL line
2	LOWER LEVEL line

Inspection of Oil Cooler for Hydraulic Oil

1. Make sure that there is no damage to the oil cooler.
2. Make sure that the oil cooler is not contaminated.

Handling Instructions

Inspection of Covers

Warning

If you have removed the cover during inspection, make sure that you replace it in the original position securely. If the cover remains removed, the operator or the mechanic may come in contact with the rotating objects or belt, or foreign objects may fly off, possibly resulting in injuries.

1. Make sure that there is no wear or deterioration of covers.
2. Make sure that there is no damage to covers.
3. Make sure that there is no interference with moving parts due to deformation of covers.
4. Make sure that covers are installed in their appropriate positions.

Inspection of Wire

1. Make sure that the wire is not cracked or damaged.
2. Make sure that the wire is not worn.
3. Make sure that the wire is not crushed.
4. Make sure that the wire is not bent.
5. Make sure that the wire is not corroded or rusted.

Inspection of Brake Pedal

1. Make sure that there is no play in the pedal.
2. Make sure that the pedal moves smoothly.
3. Make sure that there is no abnormal sound when the pedal is depressed.
4. Make sure that the pedal does not touch the floorboard when the pedal is depressed.

Inspection of Parking Brake Lever

1. Make sure that the brake pedal is locked after depressing the brake pedal completely and pulling the parking brake lever completely.
2. Make sure that the brake pedal is released after depressing the brake pedal again.

Inspection of Traveling Pedal

1. Make sure that there is no play in the pedal.
2. Make sure that the pedal moves smoothly.

3. Make sure that there is no abnormal sound when the pedal is depressed.

Inspection of Steering Wheel

1. Make sure that there is no play in the steering wheel.
2. Make sure that the steering wheel turns smoothly when it is turned.
3. Make sure that there is no abnormal sound when the steering wheel is turned.
4. Check the direction of tires when the steering wheel is turned.
 - [1] Start the engine.
 - [2] Make sure that the rear tire turns left when the steering wheel is turned right.
 - [3] Make sure that the rear tire turns right when the steering wheel is turned left.
 - [4] Stop the engine.

Inspection of Ball Proof Net

1. Check the ball proof net is not deteriorated.
2. Check there is no damage nor deformation of the ball proof net.

Inspection of Tachometer and Hour Meter

Tachometer

1. Check the tachometer is not damaged.
2. Check the tachometer operates correctly.
 - [1] Start the engine.
 - [2] Check the needle on the tachometer moves when the throttle lever is moved.
 - [3] Stop the engine.

Hour meter

1. Check the hour meter is not damaged.
2. Check the hour meter operates correctly.
 - [1] Switch the ignition key to the "ON" position.
 - [2] Check the displayed number increases correctly.
 - [3] Switch the ignition key to the "OFF" position.

Inspection of Water Temperature Gauge

1. Check the water temperature is not damaged.
2. Check the water temperature operates correctly.
 - [1] Switch the ignition key to the "ON" position.

Handling Instructions

[2] Check the water temperature needle swings.

[3] Switch the ignition key to the "OFF" position.

Inspection of Fuel Gauge

1. Check the fuel gauge is not damaged.
2. Check the fuel gauge operates correctly.
 - [1] Switch the ignition key to the "ON" position.
 - [2] Check the fuel gauge needle swings.
 - [3] Switch the ignition key to the "OFF" position.

Inspection of Pilot Lamps

1. Check the pilot lamps are clean.
2. Check the pilot lamps are not damaged.

Inspection of Safety Device

Repair the machine before operation whenever there is any abnormality.

1. Interlock system
Make sure that the interlock system operates correctly.
"Interlock System" (Page 4-9)
2. ROPS
(If the machine is equipped with ROPS and a seat belt)
Make sure that the ROPS is not damaged or broken.
3. Seat belt
(If the machine is equipped with ROPS and a seat belt)
Make sure that the seat belt is not damaged or broken.

Inspection of Bolts and Nuts

Important

The bolts and nuts may be loosened at the earlier stage of the use. Be sure to retighten or replace before operating the machine whenever there is any abnormality.

1. Check the bolts and nuts for looseness and coming off.
2. Check the bolts and nuts for cracks and damages.
3. Check the bolts and nuts for rust.

4. Check around the bolts and nuts for traces of rust fluid.

5. Check for unequal bolt length.

6. Check the bolts and nuts for stripped threads and abrasion.

Inspection of Liquid Leakage

Important

After approximately 50 hours of operation, some tightened portions may be loosened and liquid such as oil may leak. Be sure to retighten the parts.

Important

Repair the machine before operation if liquid leakage found. Ignoring leakage will cause further trouble.

1. Check the bottom of the machine for leakage of liquid such as oil, water, fuel, etc.
2. Locate the leakage and identify the type of liquid.

Mower Deck

Inspection of Rotary Knife

Caution

When touching edged tools, wear gloves since they could cut your hands.

Important

Frequently inspect the rotary knife since it may become dull quickly if the machine is operated in an environment of dry soil or sand.

1. Make sure that the rotary knife is not bent.
2. Make sure that the rotary knife is not chipped.
3. Check to see how much the rotary knife is worn.
4. Make sure that the rotary knife is not worn asymmetrically.
5. Make sure that the mounting bolt for the rotary knife is not loose.

Handling Instructions

6. Make sure that there are no cracks or tears between the sail and flat part of the rotary knife.

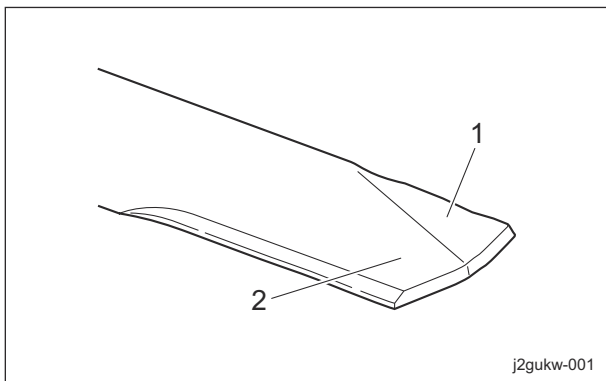

Inspection of Rotary Knife_001

1	Sail
2	Flat part

Inspection of Rollers

1. Make sure that there is no abrasion nor adhesion of the roller.
2. Make sure that there is no wear of the roller shaft.
3. Make sure that there is no wear nor damage of the oil seal.
4. Make sure that there is no wear nor rust of the bearing.
5. Make sure that there is no play in the roller shaft.

Inspection of Covers

Warning

If you have removed the shield during inspection, make sure that you re-attach it in the original position securely. If the shield remains removed, foreign objects may fly off, and the operator or the mechanic can be injured.

1. Make sure that there is no wear or deterioration in the rotary cover or shield, etc.
2. Make sure that there is no damage to the rotary cover or shield, etc.
3. Make sure that there is no interference to moving parts due to deformation of the rotary cover or shield, etc.
4. Make sure that the shield, etc., are installed in the specified locations.

Adjustment before Work

Main Vehicle

Adjustment of Steering Wheel Position

Warning

Since it is dangerous, do not adjust the steering wheel while traveling.

Caution

Be sure the steering wheel position is securely locked. It may result in an unexpected accident if it becomes loose while traveling.

The steering wheel position can be adjusted up or down according to the operator's body size.

1. Shift the tilt lever to the "FREE" position.
2. Adjust the steering wheel position.
3. Shift the tilt lever to the "LOCK" position to secure the steering wheel position.

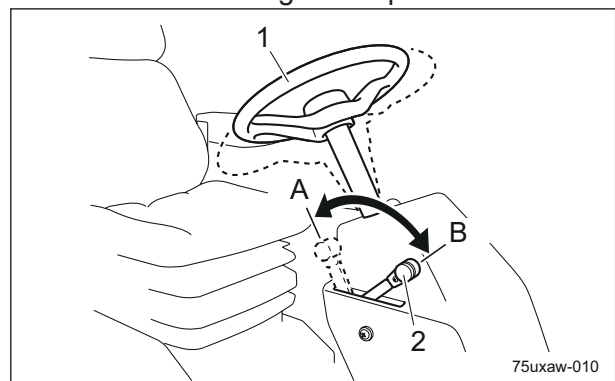

Adjustment of Steering Wheel Position_001

1	Steering wheel
2	Tilt lever
A	FREE (released)
B	LOCK (locked)

Handling Instructions

Adjustment of Seat Position

Warning

Do not make an adjustment while traveling since it is dangerous.

Use the adjustment levers to adjust the seat position.

Adjust the position to fit the operator.

1. Use the forward/backward adjustment lever to adjust the seat back and forth.
2. Use the tilt adjustment lever to adjust the angle of the backrest.
3. Turn the suspension adjustment handle to adjust the firmness of the seat suspension. Refer to the suspension indicator while making adjustments. [45 to 130 kg (99.2 to 286.6 lb)]
4. Turn the armrest adjustment knob to adjust the angle of the armrests.
5. Turn the seat height adjustment knob to adjust the height of the seat steplessly. [0 to 60 mm (0 to 2.36 in)]
Adjust the height of the seat while sitting in it.

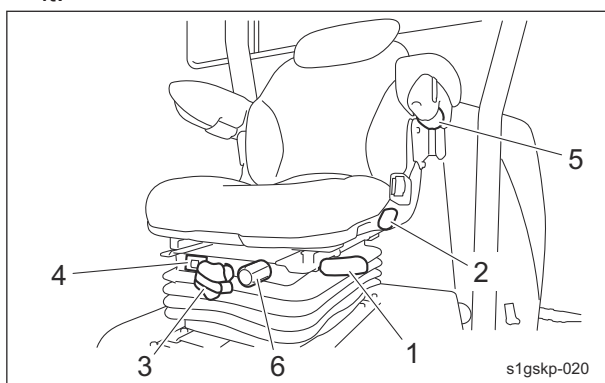

Adjustment of Seat Position_001

1	Forward/backward adjustment lever
2	Tilt adjustment lever
3	Suspension adjustment handle
4	Suspension indicator
5	Armrest adjustment knob
6	Seat height adjustment knob

Start/Stop of Engine

Procedure to Start Engine

Caution

Before starting the engine, make sure that there are no other people or obstacles around the machine.

Important

As for starting the engine, the safety device prevents the engine from starting unless it meets each of the conditions for engine starting.

Important

Starter operation must take 15 seconds or less.

If the engine does not start, stop using the battery for 30 to 60 seconds to avoid exhausting the battery.

1. Sit on the seat.
2. Make sure that the parking brake is applied.
3. Make sure that the knife rotation switch is set to the "Stop" position.
4. Make sure that the traveling pedal is in the neutral position.
5. Shift the throttle lever halfway from the "Low speed" position toward the "High speed" position.

Handling Instructions

Important

The thermo-start lamp turns off at the specified time. However, the lamp turning off is not related to the glow plug generating heat. If the ignition key is left in the "GLOW" position after the lamp is turned off, the plug will still generate heat. The lamp will stay illuminated for five seconds.

6. Switch the ignition key to the "GLOW" position.

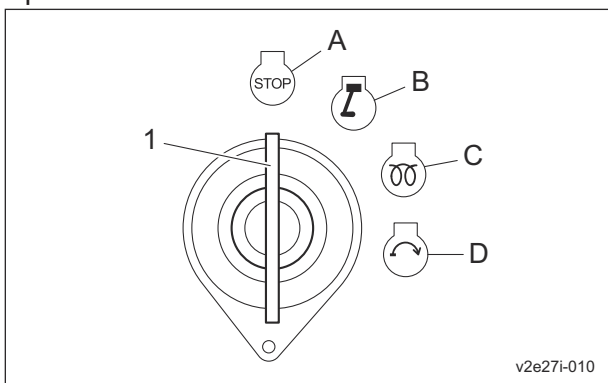

v2e27i-010

Procedure to Start Engine_002

1	Ignition key
A	OFF
B	ON
C	GLOW
D	START

7. Make sure that the thermo-start lamp is turned on.

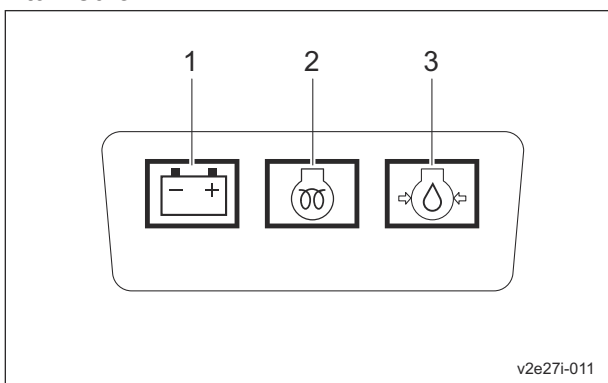

v2e27i-011

Procedure to Start Engine_003

1	Charge lamp
2	Thermo-start lamp
3	Oil pressure lamp

Important

Quickly returning the ignition key from the "START" position to the "ON" position may result in damage to the machine.

- After the thermo-start lamp turns off, immediately set the ignition key to the "START" position.
- When the starter starts rotating and the engine starts, return the ignition key to the "ON" position slowly.
- Make sure that the charge lamp and engine oil pressure lamp turn off. If they do not turn off, stop the engine and inspect the machine.

Important

Be sure to warm up the engine. Otherwise, a hydraulic system malfunction will occur.

11. Move the throttle lever to the "Low speed" position, and then warm up the engine so that the needle points above "C" on the water temperature gauge.

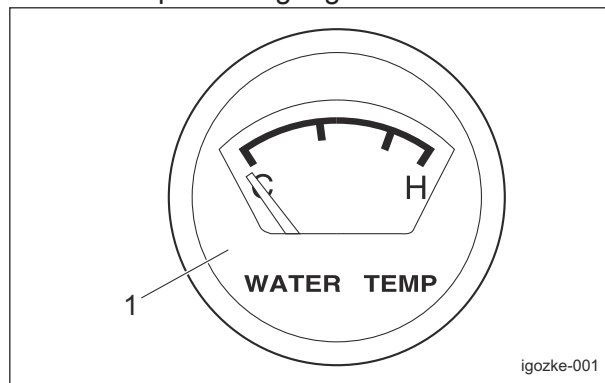

igozke-001

Procedure to Start Engine_004

1	Water temperature gauge
---	-------------------------

Procedure to Stop Engine

- Set the traveling pedal to the neutral position.
- Apply the parking brake.
- Set the knife rotation switch to the "Stop" position.
- Raise the mower decks.
- Shift the throttle lever to the "Low speed" position, and then idle the machine for 1 - 2 minutes.
- Switch the ignition key to the "OFF" position.
- Make sure that the engine has stopped.

Handling Instructions

Parking and Stopping

Procedure to Leave The Machine

⚠ Caution

If the brakes are not sufficiently effective, use the wheel stoppers to secure the machine.

⚠ Caution

Never park the machine on a slope.

1. Park the machine on level ground.
2. Apply the parking brake.
3. Stop the engine.
4. Remove the ignition key.
5. Install the cap to the key switch.
6. Hook the mower lock levers (latches) for the mower decks #4 and #5.
7. Leave the driver's seat.

Move

Traveling Procedure

⚠ Caution

Under any circumstances drive the machine at such a speed that you can stop it immediately for emergencies.

⚠ Caution

When traveling, be sure to stop the rotary knives and raise the mower decks.

Important

Do NOT start to move or stop the machine abruptly. It will damage the hydraulic system or result in oil leakage.

1. Start the engine.
2. Make sure that all the mower decks are raised and that the mower lock levers (latches) for mower decks #4 and #5 are hooked.
3. Gradually move the throttle lever toward the "High speed" position.
4. Depress the brake pedal to release the parking brake.

5. Release the brake pedal.
6. Slowly depress the traveling pedal.
7. The machine starts traveling.
8. The machine stops slowly when the traveling pedal released.

Cutting Work

Cutting Procedure

⚠ Caution

When working on a slope, be sure to use the machine in 4WD.

⚠ Caution

Cutting work must be performed at an appropriate speed for the site and location. When cutting bumpy surfaces, keep the engine rpm steady, and slow down the cutting speed.

⚠ Caution

Please note that if you stop operating the mower deck up/down lever before the mower decks are raised completely, knife rotation may not stop. Knife rotation will be turned on or off depending on the sensor-detected position of the mower decks.

⚠ Caution

Be sure that people around the machine keep a safe distance away.

Important

Do NOT start to move or stop the machine abruptly. It will damage the hydraulic system or result in oil leakage.

1. Release the mower lock levers for mower decks #4 and #5 just before cutting operation.
2. Start the engine.
"Procedure to Start Engine" (Page 5-11)
3. Set the 2WD-4WD selector switch to the "4WD".
4. Shift the throttle lever to rev the engine up to the maximum rpm.

Handling Instructions

5. Depress the brake pedal to release the parking brake.
6. Shift the mower deck up/down lever to the "Lower" position to lower the mower decks.
7. Set the knife rotation switch to the "Rotation" position to rotate the rotary knives of all mower decks.
8. Depress the traveling pedal to start cutting work.

Note:

During the work, the rotary knives will rotate or stop in sync with the up and down motion of the mower decks.

Transporting

Transporting Procedure

When loading the machine into a trailer or a truck to transport it, drive the machine forward. When unloading, drive the machine in reverse. If the roof is installed on the machine, remove it.

The roof may be damaged by wind pressure.

Cleaning after Use

The purpose of the machine cleaning is to:

- Prevent accidents
- Prevent damage to the machine
- Maintain machine performance

Properly clean the machine to maintain its functionality and performance.

If you detect any abnormalities with the machine, immediately perform maintenance or repairs.

Engine

Cleaning of Radiator Cover

Important

An unclean radiator cover may cause overheating or damage to the engine. It may also cause malfunction of the hydraulic system.

If the radiator cover has been contaminated with dust, be sure to clean it.

After operating the machine in a dusty environment, it is important to remove dust from the cover as soon as possible.

1. Open the radiator cover.

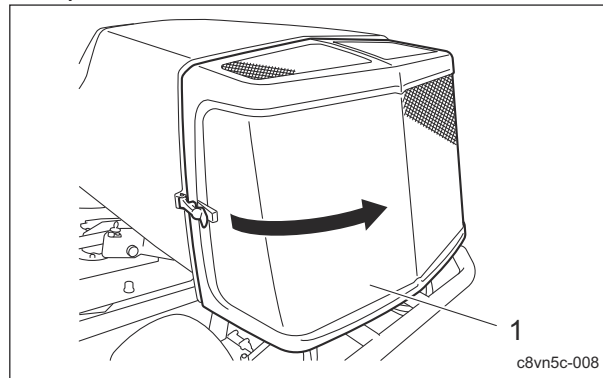

Cleaning of Radiator Cover_001

1	Radiator cover
---	----------------

2. Carefully clean the front and back of the radiator cover with water or compressed air.

Cleaning of Radiator

Important

An unclean radiator may cause overheating or damage to the engine. It may also cause malfunction of the hydraulic system.

Important

Do not use solid objects, such as a spatula or screwdriver, or high-pressure water to clean the radiator or oil cooler. Otherwise, special fins or tubes may be damaged, possibly resulting in reduced cooling performance or coolant leakage.

If the radiator has been contaminated with dust, be sure to clean it.

After operating the machine in a dusty environment, it is important to remove dust as soon as possible.

1. Open the radiator cover.

Handling Instructions

- Unlock the rubber catches on the left and right of the oil cooler, and then tilt the oil cooler.

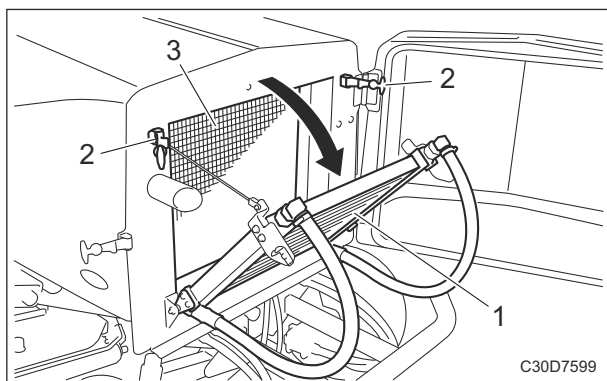

Cleaning of Radiator_001

1	Oil cooler
2	Rubber catch
3	Radiator

- Carefully clean the front and back of the radiator with water or compressed air.

Cleaning of Engine-Associated Parts

⚠ Caution

Perform operations after the muffler, engine and other parts have sufficiently cooled. Otherwise, you may get burned.

- Clean clippings and remove dirt.
- Blow compressed air to clean any grass or flammable materials that may be attached on or around the muffler.

Main Vehicle

Cleaning of Oil Cooler

Important

An unclean oil cooler may cause malfunction of the hydraulic system.

Important

Do not use solid objects, such as a spatula or screwdriver, or high-pressure water to clean the radiator or oil cooler. Otherwise, special fins or tubes may be damaged, possibly resulting in reduced cooling performance or coolant leakage.

If the oil cooler has been contaminated with dust, be sure to clean it. After operating the machine in a dusty environment, it is important to remove dust as soon as possible.

- Open the radiator cover.
- Unlock the rubber catches on the left and right of the oil cooler, and then tilt the oil cooler.

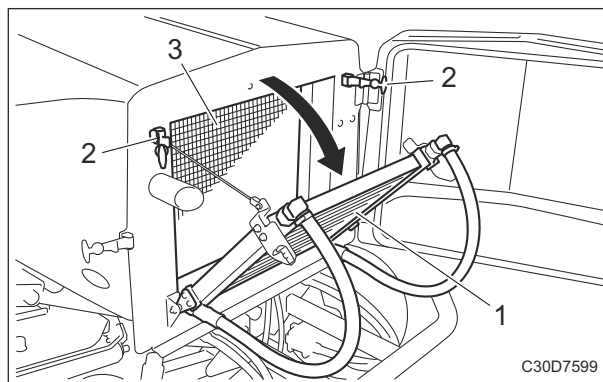

Cleaning of Oil Cooler_001

1	Oil cooler
2	Rubber catch
3	Radiator

- Carefully clean the front and back of the oil cooler with water or compressed air.

Mower Deck

Cleaning of Mower Deck

Be sure to clean the mower deck after use.

- Stop the engine, and then remove the key.
- Carefully clean the front and back of the mower deck with water or compressed air.
- Remove any grass wrapped around the rotary knife.

Handling Instructions

Storage

Short-Term Storage

Short-term storage means that the machine is temporarily stored (within 1 month) without use.

Follow the instructions below for short-term storage of this machine.

1. Cleaning

- Remove dirt, grass clippings, oil stains etc. completely from the main vehicle and engine.

2. Mower decks

- When storing this machine, lower all the mower decks unless a positive mechanical lock is provided.

3. Storage location

- Cover the machine and store it in a dry place where it will not be exposed to rain.

Precautions for Maintenance	Page 6-2
Operations before Maintenance	Page 6-2
Swiveling Mower Decks #2 and #3	Page 6-2
Jacking Up The Machine	Page 6-3
About Jacking Up The Machine	Page 6-3
Jack-Up Points	Page 6-3
Inspection and Cleaning	Page 6-4
Engine	Page 6-4
Main Vehicle	Page 6-7
Supplying Fluids	Page 6-8
Engine	Page 6-8
Main Vehicle	Page 6-10
Greasing	Page 6-12
About Greasing	Page 6-12
Greasing Points	Page 6-12
Lubrication	Page 6-15
About Lubrication	Page 6-15
Lubricating Points	Page 6-16
Adjustment	Page 6-16
Engine	Page 6-16
Mower Deck	Page 6-17
Replacement	Page 6-22
Engine	Page 6-22
Main Vehicle	Page 6-26
Mower Deck	Page 6-32
Storage	Page 6-36
Long-Term Storage	Page 6-36

Maintenance

Precautions for Maintenance

Warning

The chapter "Maintenance" in this manual describes practical measures which should be performed by a mechanic with expertise. The owner should instruct the mechanic with expertise to perform maintenance service for this machine.

Caution

First, learn well the operations you plan to perform.

Important

Use tools appropriate for each operation.

Important

Use Baronsess genuine parts for replacement and accessories. Our product warranty may be void if you use non-genuine parts for replacement or accessories.

Operations before Maintenance

Swiveling Mower Decks #2 and #3

Caution

The rotary knife is an edged tool. Take extra care in handling since they could cut your hands or legs.

Caution

Be careful not to inhale exhaust gas while swiveling the mower decks.

Maintenance can be performed more easily with mower decks #2 and #3 swiveled.

1. Lower the mower decks, and then stop the engine.

2. Remove the clip pin, and then remove the grip pin.

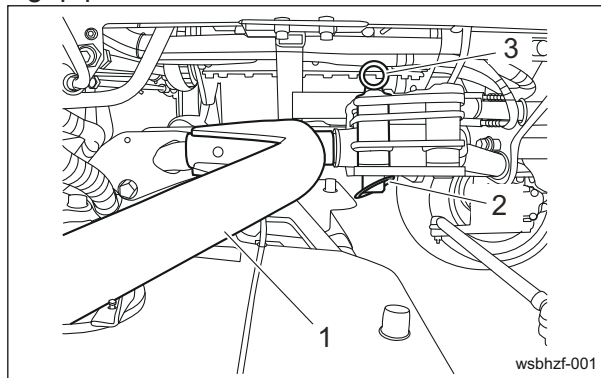

Swiveling Mower Decks #2 and #3_001

1	Mower arm
2	Clip pin
3	Grip pin

3. Swivel the mower deck toward the outside of the main vehicle.

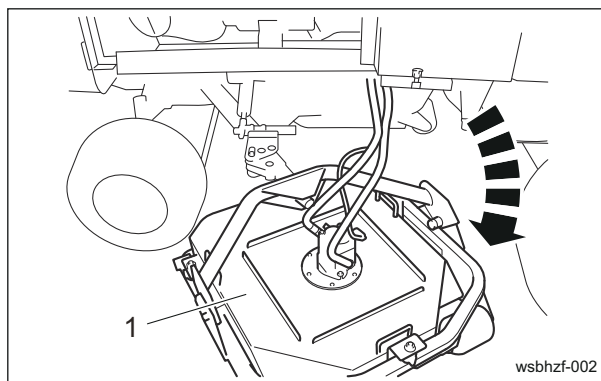

Swiveling Mower Decks #2 and #3_002

1	Mower deck
---	------------

4. Fully insert the grip pin into the locking hole for maintenance, and then install the clip pin in the grip pin.

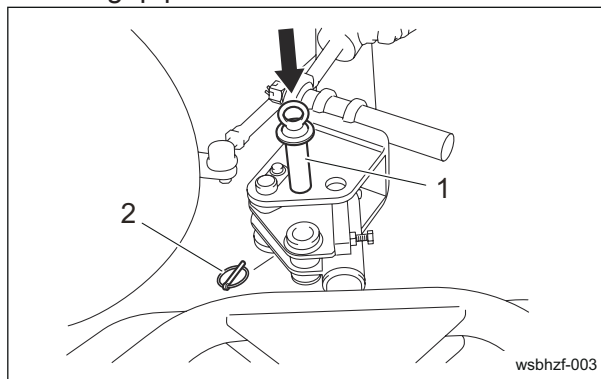

Swiveling Mower Decks #2 and #3_003

1	Grip pin
2	Clip pin

5. Start the engine, and then raise the mower decks.

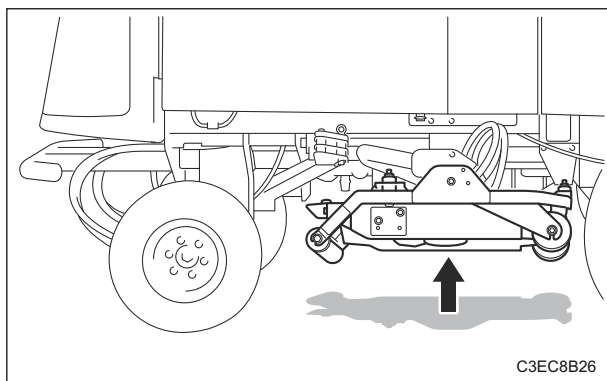

Swiveling Mower Decks #2 and #3_004

6. After the maintenance is completed, reverse the procedure to return the machine to its original condition.

Jacking Up The Machine

About Jacking Up The Machine

Warning

When replacing a tire or beginning any other maintenance or repairs, be sure to chock the wheels to prevent the machine from moving. Before jacking up the machine, park it on a hard, flat surface such as a concrete floor and remove any obstacles that could prevent you from performing the work safely. When necessary, use an appropriate chain block, hoist, or jack. Support the machine securely with jack stands or appropriate blocks. Failure to do so may cause the machine to move or fall, resulting in injury or death.

Important

Only place a jack under the jack-up points specified. Placing a jack at any other point will result in damage to the frame or other parts.

Use the jack-up points identified in this manual when jacking up the machine.

Jack-Up Points

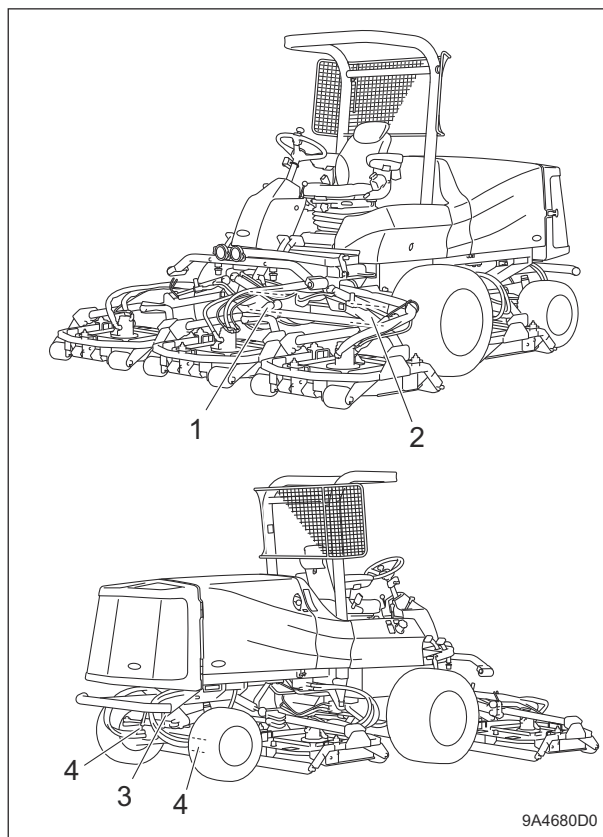

Jack-Up Points_001

	Jack-up points
1	Front right frame
2	Front left frame
3	Center of pivot
4	Below rear wheel motors

1. Front right frame

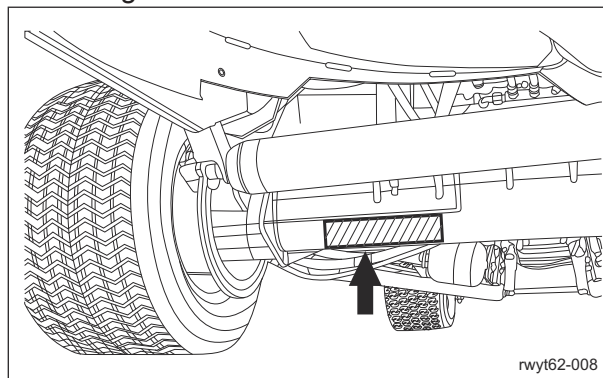

Jack-Up Points_002

Maintenance

2. Front left frame

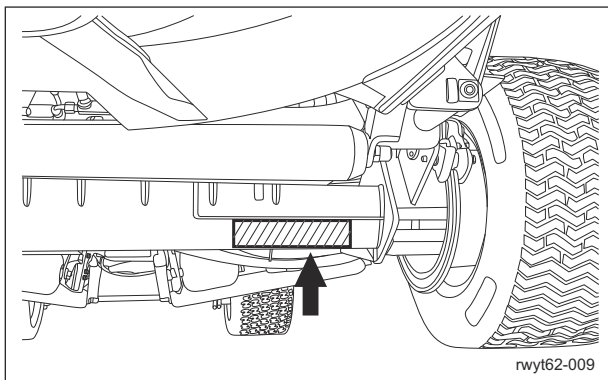

Jack-Up Points_003

3. Center of pivot

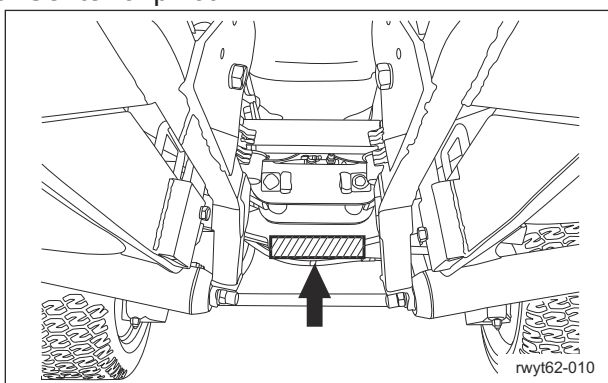

Jack-Up Points_004

4. Below rear wheel motors Two locations

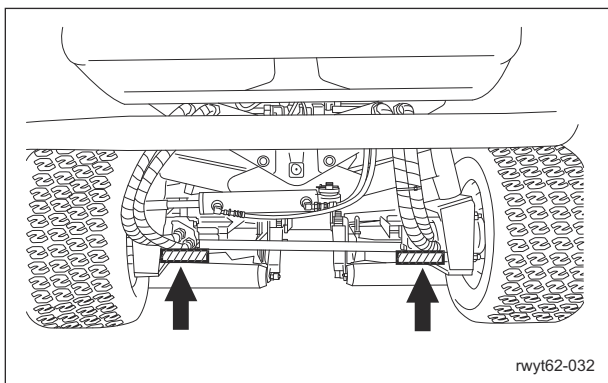

Jack-Up Points_005

Inspection and Cleaning

Inspect and clean the machine with the goals of the followings.

- Accident prevention
- Failure prevention
- Performance retention

Make efforts for early detection of the machine failure and prevention of the sudden occurrence of trouble.

Perform maintenance and repair works immediately if any abnormality is found in the machine.

Engine

Cleaning of Air Cleaner Element

A contaminated air cleaner element may cause malfunction of the engine. To maximize the life of the engine, clean the air cleaner properly.

1. Follow the steps below to clean the air cleaner filter.

[1] Remove the clips and remove the air cleaner cap.

[2] Remove the air cleaner filter.

[3] While paying close attention not to damage the air cleaner filter, tap a solid portion of the air cleaner element or blow compressed air from its inside to remove dust and dirt.

If the air cleaner element is extremely contaminated, replace it with a new one.

[4] Attach the air cleaner element to the air cleaner body.

[5] Install the air cleaner cap, and then affix it securely using the clips.

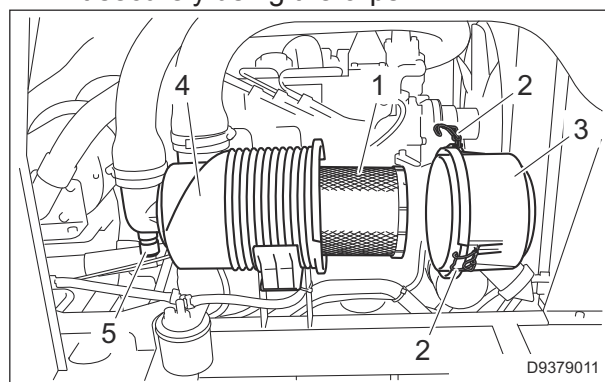

Cleaning of Air Cleaner Element_001

1	Air cleaner filter
2	Clip
3	Air cleaner cap
4	Air cleaner body
5	Vacuum indicator

2. Press the reset button for the vacuum indicator.

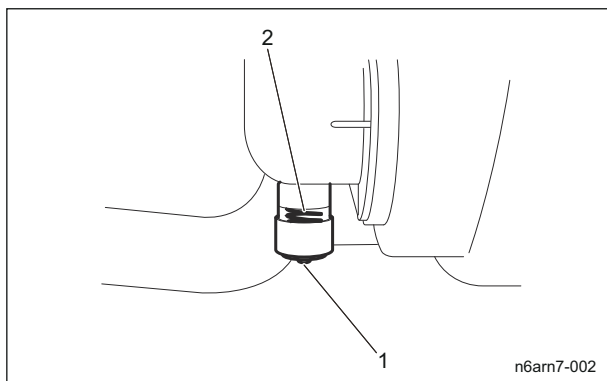

Cleaning of Air Cleaner Element_002

1	Reset button
2	Vacuum indicator

Inspection of Water Separator

Important

Water-contaminated fuel may impair engine startability, decrease output or damage engine parts.

1. Make sure that the water separator is not damaged or dirty.
2. Make sure that there is no water leakage.
3. Make sure that debris and water have not accumulated in the cup.
With the float raised, water contamination is confirmed.
When the float reaches the drain level, drain the water.

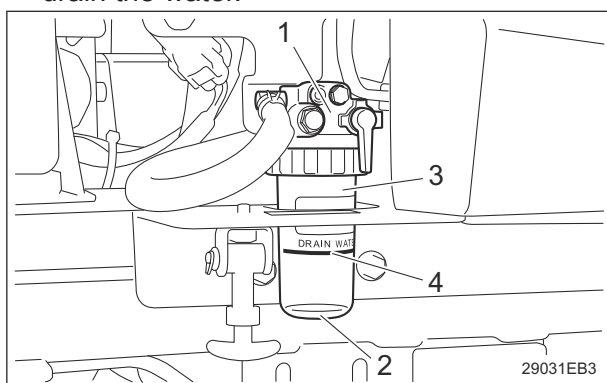

Inspection of Water Separator_001

1	Water Separator
2	Float
3	Cup
4	Drain level

Draining of Water Separator

Important

Water-contaminated fuel may impair engine startability, decrease output or damage engine parts.

Drain the water after at least the number of hours in the Maintenance Schedule and whenever the float is raised by water.

1. Stop the engine, and then turn the key switch to the "OFF" position.
2. Place a container under the water separator.
3. Close the fuel cock of the water separator.

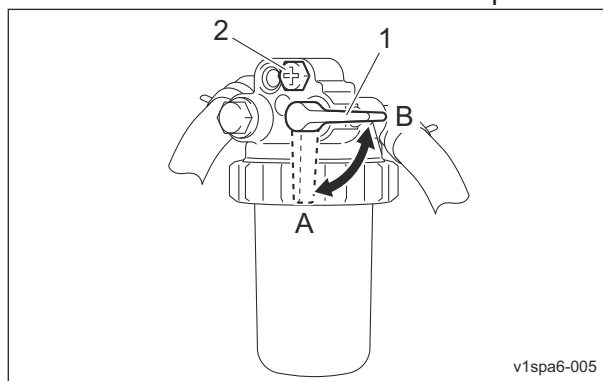

Draining of Water Separator_001

1	Fuel cock
2	Air-bleeding plug
A	ON (open)
B	OFF (close)

4. Remove the ring nut, and then remove the cup.

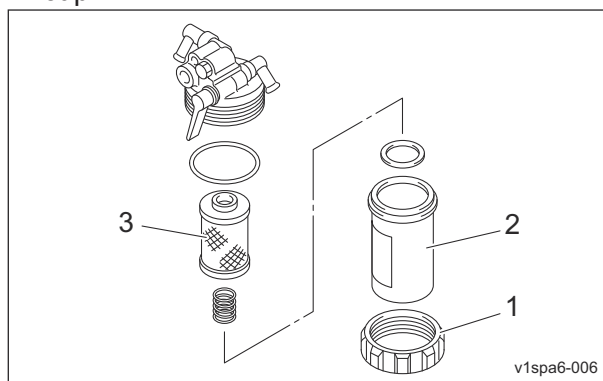

Draining of Water Separator_002

1	Ring nut
2	Cup
3	Element

Maintenance

5. Drain the water from the cup.

Important

During installation, prevent contamination with dirt or dust.

If the fuel is contaminated with dirt, dust, etc., the fuel injection pump and injection nozzle will become worn.

6. Correctly install all parts in their original positions.
7. Fill up the fuel tank with fuel.
8. Open the fuel cock of the water separator.

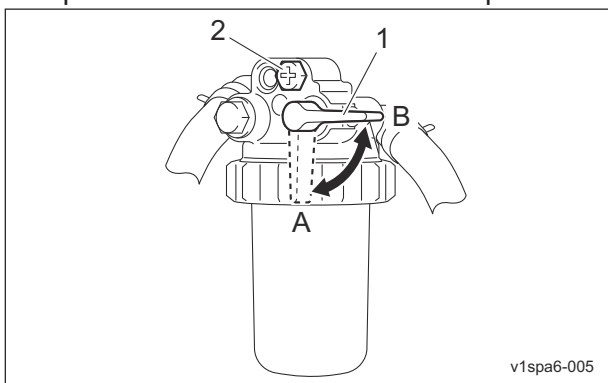

Draining of Water Separator_003

1	Fuel cock
2	Air-bleeding plug
A	ON (open)
B	OFF (close)

9. Set the ignition key to the "ON" position.
10. Loosen the air-bleed plug to bleed the air.
11. When the cup is filled with fuel, close the air-bleed plug.
12. Set the ignition key to the "OFF" position.
13. If the engine does not start within 15 seconds after switching the ignition key to the "START" position, wait at least 30 seconds, and then repeat the same operation.
If there is still air in the cup after starting the engine, bleed the air again.

Cleaning of Water Separator

Important

Water-contaminated fuel may impair engine startability, decrease output or damage engine parts.

Clean the water separator after at least the number of hours in the Maintenance Schedule and whenever debris has accumulated in the cup.

1. Stop the engine, and then turn the key switch to the "OFF" position.
2. Place a container under the water separator.
3. Close the fuel cock of the water separator.

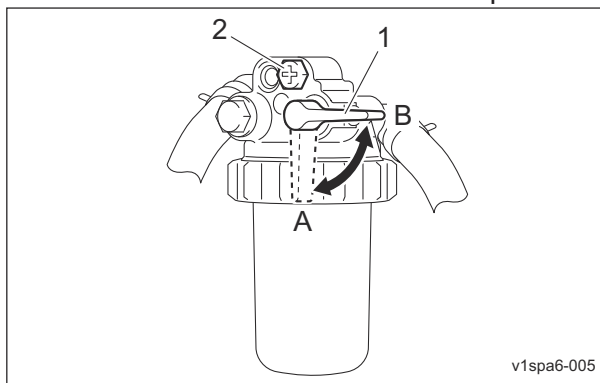

Cleaning of Water Separator_001

1	Fuel cock
2	Air-bleeding plug
A	ON (open)
B	OFF (close)

4. Remove the ring nut, and then remove the cup.

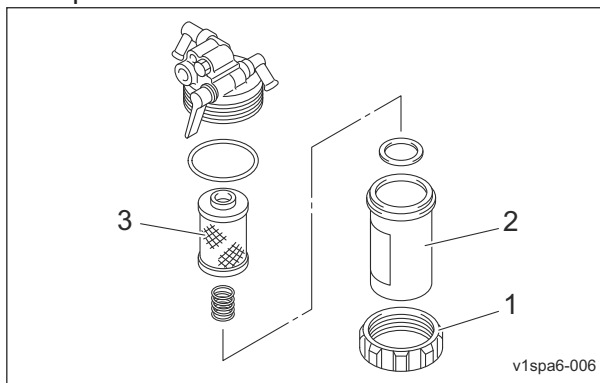

Cleaning of Water Separator_002

1	Ring nut
2	Cup
3	Element

5. Drain the water from the cup.
6. Clean the cup and element with diesel fuel.

Important

During installation, prevent contamination with dirt or dust.

If the fuel is contaminated with dirt, dust, etc., the fuel injection pump and injection nozzle will become worn.

7. Correctly install all parts in their original positions.
8. Fill up the fuel tank with fuel.
9. Open the fuel cock of the water separator.

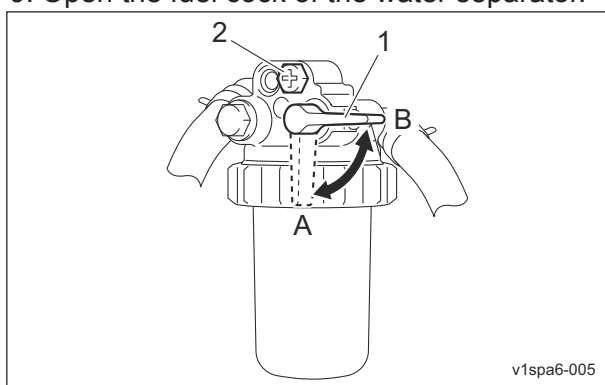

Cleaning of Water Separator_003

1	Fuel cock
2	Air-bleeding plug
A	ON (open)
B	OFF (close)

10. Set the ignition key to the "ON" position.
11. Loosen the air-bleeding plug to bleed the air.
12. When the cup is filled with fuel, close the air-bleeding plug.
13. Set the ignition key to the "OFF" position.
14. If the engine does not start within 15 seconds after switching the ignition key to the "START" position, wait at least 30 seconds, and then repeat the same operation.
If there is still air in the cup after starting the engine, bleed the air again.

Inspection of Belt

Warning

The engine must be stopped when the belt is inspected.

Important

A slacking or damaged belt or damaged fan may cause overheating or lack of a battery charge.

1. Check the belt tension.
2. Make sure that there are no cracks and damage on the belt.
3. Make sure that there is no abnormal wear on the belt.

Main Vehicle

Inspection of Hydraulic Hoses and Pipes

Warning

When checking the hydraulic circuit for pinhole leaks or oil leakage from nozzles, do not use your hands. Use items such as paper or corrugated cardboard to find leakage points.

Be extremely careful with high-pressure oil as it may pierce your skin, resulting in personal accidents.

If fluid is injected into the skin it must be surgically removed within a few hours by a doctor familiar with this form of injury or gangrene may result.

1. Make sure that there is no wear, deterioration or damage in the hydraulic hoses and pipes.
2. Make sure that there is no looseness in the connecting portion of the hydraulic hoses and pipes.
3. Check underneath the machine for hydraulic oil leakage.

Inspection of Electrical Wiring

Important

Electrical short circuit will cause fire, electrical leakage and malfunction of electrical equipments.

1. Make sure that there is no defacement in wires and terminals.
2. Make sure that there is no deterioration or damage in wires and terminals.
3. Make sure that there is no looseness in wiring connections.

Maintenance

4. Make sure that there is no poor terminal connection.

Inspection of Wheel Mounting Bolt

Important

Tighten the wheel mounting bolts on the specified torque by using a torque wrench.

1. Check the wheel mounting bolts and wheel nuts for looseness and coming off.
2. Check the wheel mounting bolts and wheel nuts for cracks and damages.
3. Check the wheel mounting bolts and wheel nuts for rust.
4. Check around the wheel mounting bolts and wheel nuts for traces of rust fluid.
5. Check the wheel mounting bolts for unequal bolt length.
6. Check the wheel mounting bolts and wheel nuts for stripped threads and abrasion.

Supplying Fluids

Engine

Supply of Engine Oil

Important

Do not supply too much engine oil. Otherwise, the engine may be damaged.

Important

Do not mix different types of engine oil.

Important

Be sure to use engine oil that is classified as API Service Grade CF or higher, with an SAE Viscosity that is appropriate for the operating environment (ambient temperature).

Important

Securely install the oil level gauge and oil filler cap.

If the engine oil level is lower than the lower limit line on the oil level gauge, supply engine oil through the oil filling port.

There are two oil filling ports on the engine. Use either one.

1. Remove the oil filler cap.
2. Supply new engine oil until the oil reaches a level in between the upper and lower limit lines on the oil level gauge.
3. Install the oil filler cap.



Supply of Engine Oil_001

1	Oil level gauge
2	Oil filler cap

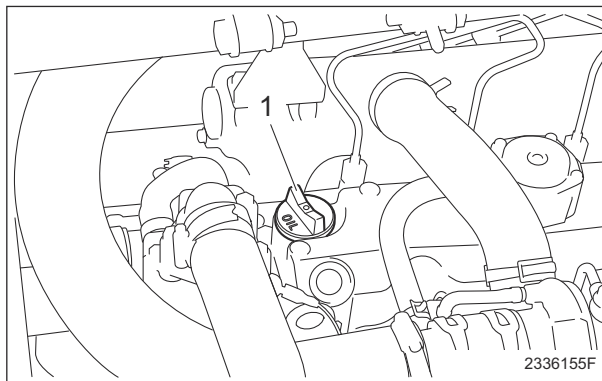

Supply of Engine Oil_002

1	Oil filler cap
---	----------------

4. It will take a while for the supplied engine oil to descend into the oil pan. Check the oil level again 10 to 20 minutes after supplying the oil.

Supply of Coolant

Caution

Do not touch the radiator or coolant during engine operation or right after the engine has been turned off. Due to high temperatures, doing so could cause burns.

Caution

Supply coolant after the engine has well cooled down.

Caution

The radiator cap is pressurized. If you remove the radiator cap while the engine is overheated, hot steam will burst out, possibly resulting in burns. Make sure that the water temperature and pressure are reduced, and then grab the cap with a thick cloth and gradually open the cap.

Important

When you supply coolant, be sure to mix clean water and antifreeze (long-life coolant), and then pour it into the radiator and reserve tank.

Important

Tightly close the radiator cap. If the cap is loose or incorrectly installed, the engine will be overheated due to water leakage, resulting in engine damage.

When mixing antifreeze and clean water, refer to "Relationship between concentration of long-life coolant (LLC) and freezing temperature" below for the mixing ratio.

Relationship between concentration of long-life coolant (LLC) and freezing temperature

Freezing temperature	LLC concentration (volume %)
Down to -10 °C (14 °F)	20 %
Down to -15 °C (5 °F)	30 %
Down to -20 °C (-4 °F)	35 %
Down to -25 °C (-13 °F)	40 %

If the coolant level in the reserve tank is low, supply clean water and antifreeze.

1. If the coolant level in the reserve tank is lower than the "LOW" mark, follow the steps below to fill the tank.
 - [1] Remove the reserve tank cap.
 - [2] Supply clean water and antifreeze up to the "FULL" mark of the reserve tank.
 - [3] Install the reserve tank cap.

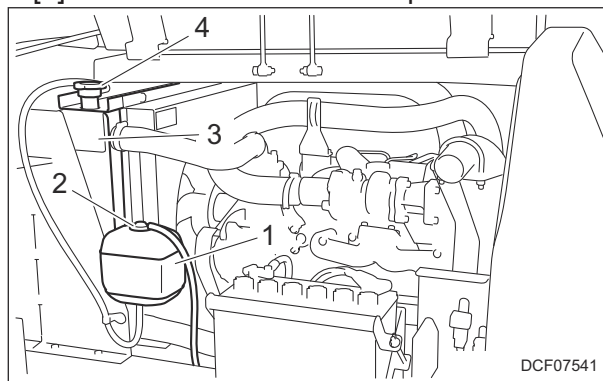

Supply of Coolant_001

1	Reserve tank
2	Reserve tank cap
3	Radiator
4	Radiator cap

2. If no coolant is in the reserve tank, follow the steps below to fill the tank.
 - [1] Remove the radiator cap.
 - [2] Supply clean water and antifreeze up to the opening of the radiator.
 - [3] Install the radiator cap.
 - [4] Remove the reserve tank cap.
 - [5] Supply clean water and antifreeze up to the "FULL" mark of the reserve tank.
 - [6] Install the reserve tank cap.

Maintenance

Main Vehicle

Supply of Hydraulic Oil

Important

Do not mix different types of oil.

Important

For the hydraulic oil to be used, consult Characteristics of Hydraulic Oil and use the oil whose characteristics are equivalent or superior to those specified there. Especially regarding kinematic viscosity and viscosity index, use of hydraulic oil whose figures are less than those of the specified hydraulic oil will cause a malfunction in the hydraulic circuit.

Important

Supply hydraulic oil after checking the oil in the hydraulic tank has been sufficiently cooled down. Oil level changes depending on the hydraulic oil temperature.

■ Characteristics of Hydraulic Oil

ISO Viscosity Grade		ISO VG46
Density	15 °C (59 °F)	0.873 g/cm ³ (0.0315 lb/in ³)
API Gravity		30.6
Flash Point (Open Cup)		230 °C (446 °F)
Pour Point		-30 °C (-22 °F)
Kinematic	40 °C (104 °F)	46 mm ² /s (46 cSt)
Viscosity	100 °C (212 °F)	7 mm ² /s (7 cSt)
Viscosity Index		109

■ Characteristics of Hydraulic Oil with conditions of use

Hydraulic oil of ISO viscosity grade VG68 can be used only if the following condition is met:

- The outside temperature must be 20 °C (68 °F) or more during engine operation.

ISO Viscosity Grade		ISO VG68
Density	15 °C (59 °F)	0.878 g/cm ³ (0.0318 lb/in ³)
API Gravity		29.7
Flash Point (Open Cup)		252 °C (486 °F)
Pour Point		-30 °C (-22 °F)
Kinematic	40 °C (104 °F)	68 mm ² /s (68 cSt)
Viscosity	100 °C (212 °F)	9 mm ² /s (9 cSt)
Viscosity Index		107

Note:

In Japan, "Shell Tellus S2M46 (ISO VG46)" and "Shell Tellus S2M68 (ISO VG68)" meet the characteristics described above.

However, in other countries, the specification of Shell Tellus S2M46 and Shell Tellus S2M68 can be below what is required.

Please check the product data sheet to ensure that it meets the requirements before using.

1. Remove the left tank cover.
2. If the oil level is low, follow the steps below to supply oil.
 - #20001 - 20071
 - [1] Open the tank cap.
 - [2] Supply hydraulic oil through the oil filling port until the oil level reaches the middle of the oil gauge on the hydraulic tank.
 - [3] Tighten the tank cap securely.

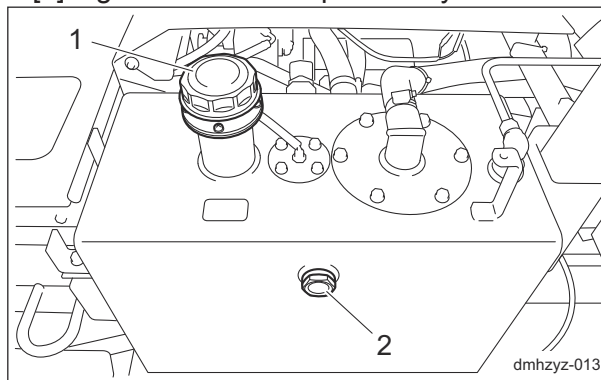

Supply of Hydraulic Oil_001

1	Tank cap
2	Oil gauge

■ #20072-

- [1] Loosen the bushing with a wrench and remove the oil filler plug.
- [2] Supply hydraulic oil through the oil filling port until the oil level reaches the middle of the oil gauge on the hydraulic tank.

- [3] Install the oil filler plug and tighten the bushing securely.

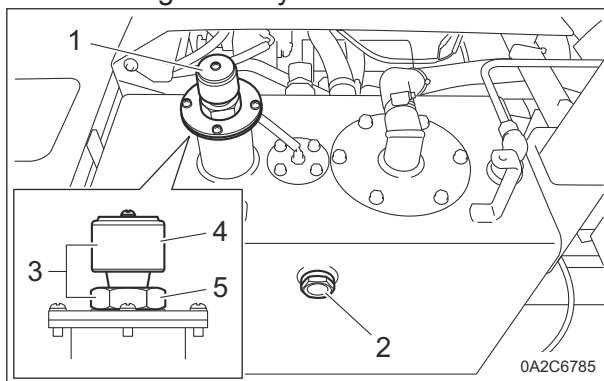

Supply of Hydraulic Oil_002

1	Tank cap
2	Oil gauge
3	Oil filler plug
4	Air breather
5	Bushing

3. Start the engine, and then repeat the steps below a few times.
 - Raise and lower the mower units.
 - Turn the steering wheel left and right.
 - Move forward and reverse.
4. Lower the mower decks and maintain that position on a level surface, check to see if the oil level is at the middle of the oil gauge. If the hydraulic oil level is low, supply oil again until it reaches the specified level.
5. Check underneath the machine for oil leakage.
6. Install the left tank cover.

Supply of Battery Fluid

⚠ Danger

If battery fluid comes into contact with eyes, it may result in blindness. Immediately flush with plenty of water and take medical care from an ophthalmologist.

⚠ Danger

Do not drink battery fluid. If battery fluid enters the mouth or is swallowed, it may result in burns inside the mouth. Immediately and repeatedly gargle with plenty of water, then drink plenty of water, and take medical care.

⚠ Danger

When you supply battery fluid, wear protective garments and safety glasses, etc.

⚠ Warning

If battery fluid adheres to the skin or clothing, it may cause burns or damage clothing. Immediately flush with plenty of water, then wash thoroughly with soap.

⚠ Warning

Do not allow the battery fluid level to become lower than the LOWER LEVEL (minimum fluid level line). The battery may explode if it is used or charged while the battery fluid level is at the LOWER LEVEL (minimum fluid level line).

⚠ Warning

When refilling, do not fill purified water above the UPPER LEVEL (maximum fluid level line). Doing so may result in electrolyte leaks.

⚠ Caution

Implement after the engine and muffler etc. have well cooled down. Otherwise, you may get burned.

Important

If battery fluid adheres to the vehicle, it may cause corrosion. Wipe it off with a cloth dampened with water, and then flush with water.

If the battery fluid level is lower than halfway between the UPPER LEVEL (maximum fluid level line) and LOWER LEVEL (minimum fluid level line), add purified water.

1. Loosen the vent plug and remove it.
2. Add purified water up to the UPPER LEVEL (maximum fluid level line)
3. Tighten the vent plug securely.

Maintenance

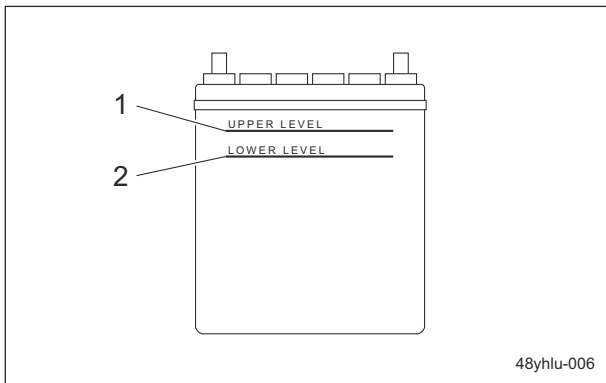

48yhlu-006

Supply of Battery Fluid_001

1	Maximum fluid level line
2	Minimum fluid level line

Greasing

About Greasing

Since there may be adhesion or damage due to lack of grease on moving parts, they must be greased.

Add urea-based No. 2 grease in accordance with the Maintenance Schedule.

Other locations where the specified grease or lubricant is used are indicated in "Greasing Points".

Add grease using the specified grease or lubricant.

Greasing Points

Grease nipples are installed in the following locations.

Add grease every 50 hours of operation.

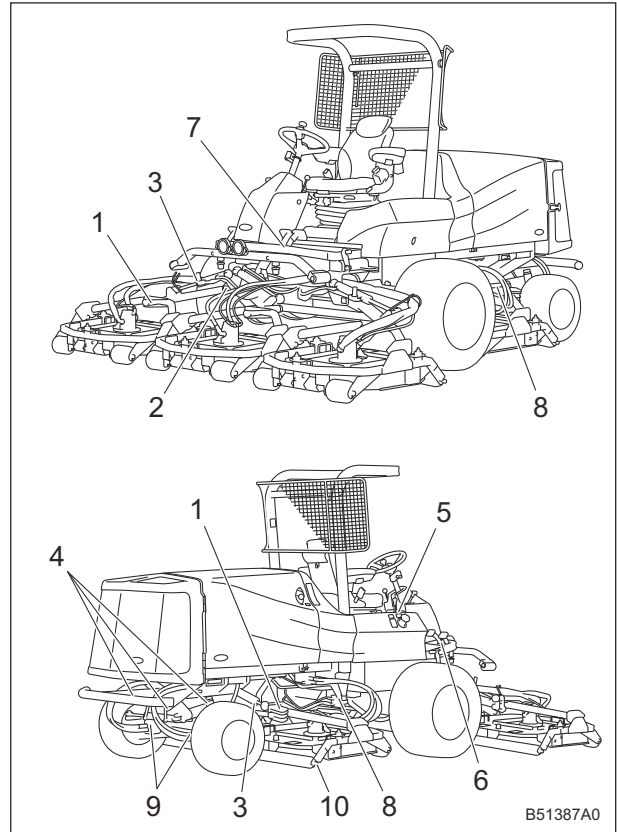

B51387A0

Greasing Points_001

	Portion	No. of Greasing Points
1	Mower arm fulcrum	5
2	Lift arm fulcrum	5
3	Lift arm cylinder fulcrum	12
4	Pivot	3
5	Neutral position area	2
6	Traveling pedal shaft fulcrum	2
7	Foot brake	3
8	Rear mower deck swing out pin	2
9	Tie rod end (#20102-)	2
10	Rear roller (#20110-)	10

1. Mower arm fulcrum

There is one greasing point on the arm connected to each mower deck.

Mower decks #1, #4 and #5

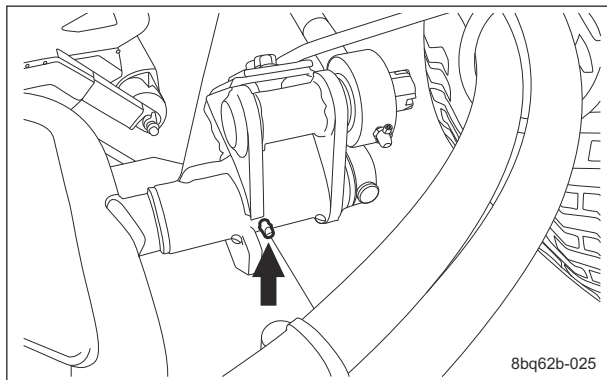

Greasing Points_002

Mower decks #2 and #3

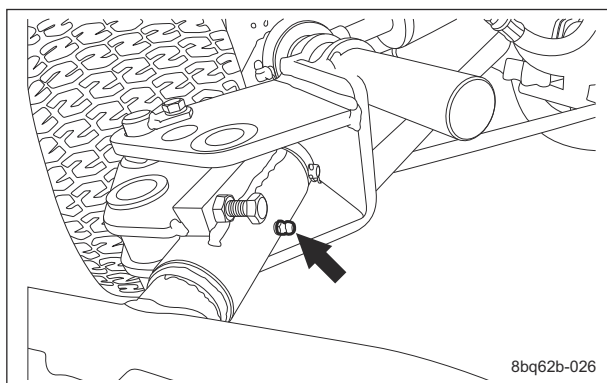

Greasing Points_003

2. Lift arm fulcrum

There is one greasing point on the arm connected to each mower deck.
Lower the mower decks before greasing the lift arm fulcrums.

Mower decks #1 and #4

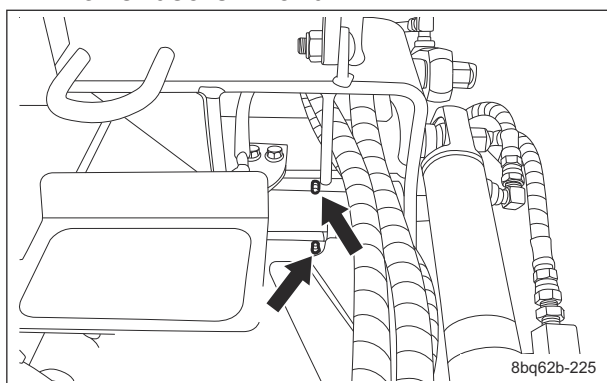

Greasing Points_004

Mower decks #2 and #3

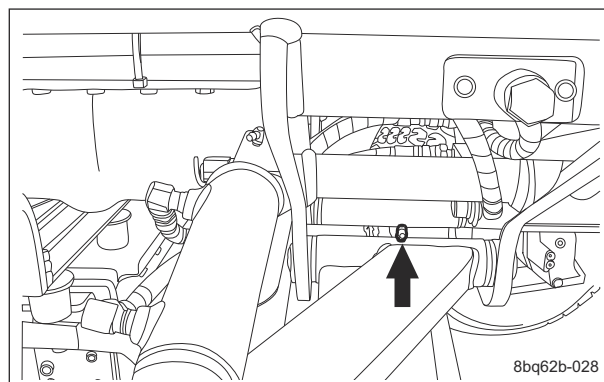

Greasing Points_005

Mower deck #5

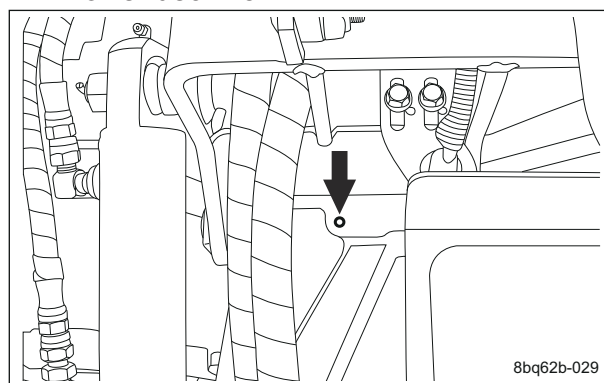

Greasing Points_006

3. Lift arm cylinder fulcrum

This is on each cylinder of the arms connected to each mower deck.

Mower decks #1, #4 and #5

There are two greasing points on each cylinder.

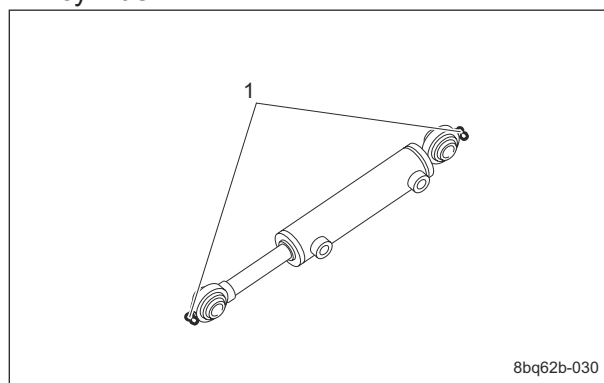

Greasing Points_007

1	Grease nipple
---	---------------

Maintenance

Mower decks #2 and #3

There are three greasing points on each cylinder.

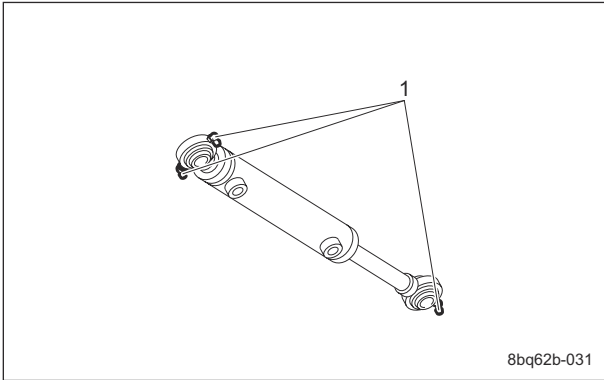

Greasing Points_008

1	Grease nipple
---	---------------

4. Pivot

Middle between the rear wheels

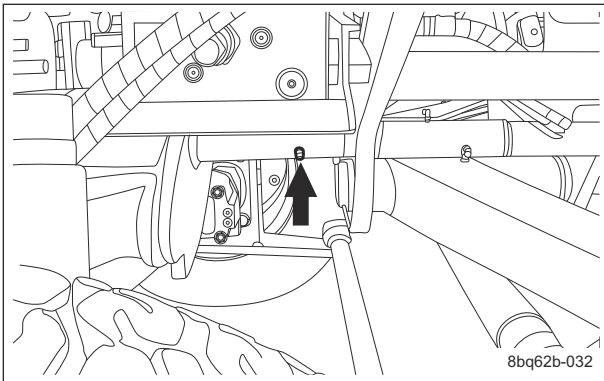

Greasing Points_009

Rear left wheel

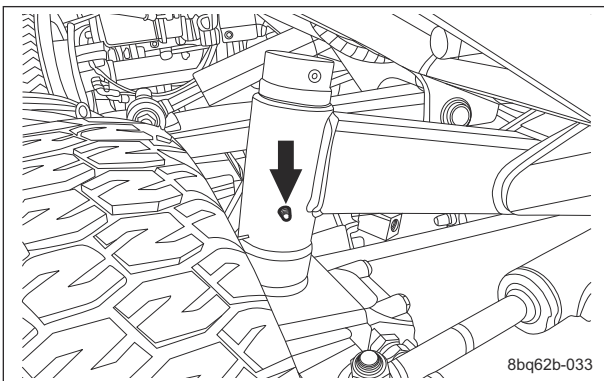

Greasing Points_010

Rear right wheel

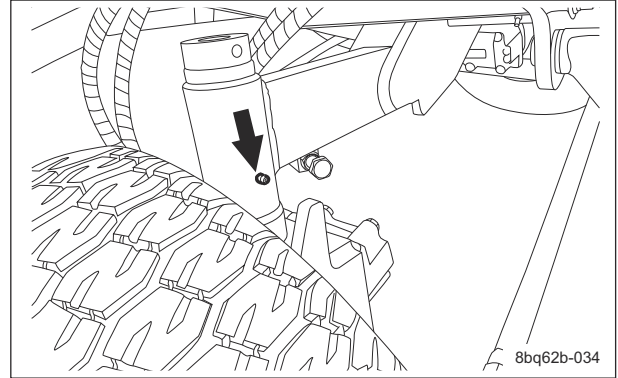

Greasing Points_011

5. Neutral position area

There are two locations.

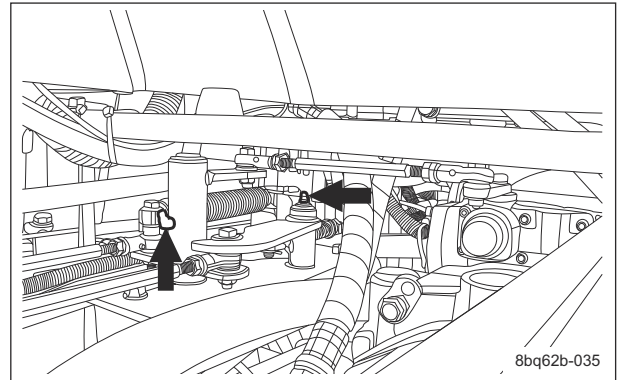

Greasing Points_012

6. Traveling pedal shaft fulcrum

There are two locations.

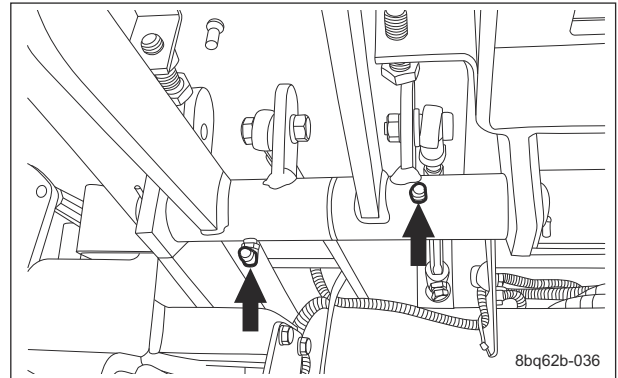

Greasing Points_013

7. Foot brake

There are three locations.

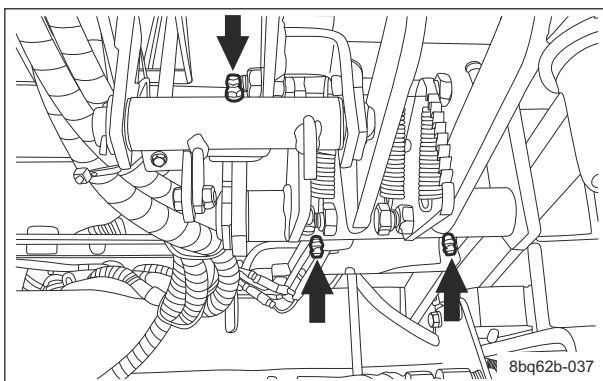

Greasing Points_014

8. Rear mower deck swing out pin

There is one point on the mower decks #2 and #3.

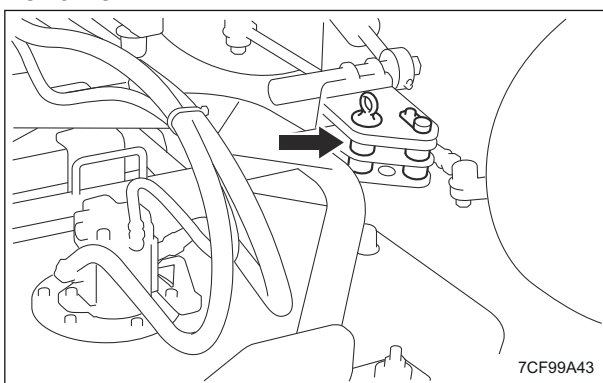

Greasing Points_015

9. Tie rod end

There is one point each on the left and right tie rod ends.

Add 9 g (0.02 lb) of DYNAMAX GREASE EP NO.1 every 3 months of operation.

Note:

Add grease with the steering wheel turned to the left/right completely.

The appropriate greasing amount is that it sticks out a little from the tie rod end rubber boot.

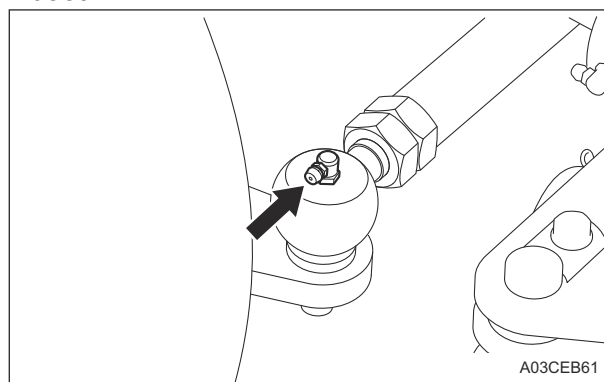

Greasing Points_016

10. Rear roller

There is one greasing point each on the left and right of each mower deck.

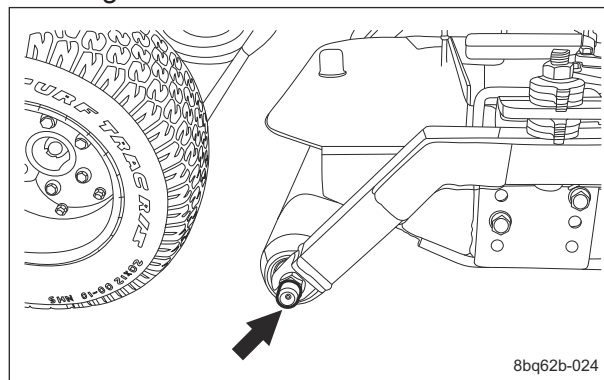

Greasing Points_017

Lubrication

About Lubrication

It is necessary to lubricate moving parts so that they will not become stuck or damaged.

The locations where lubricant is used are indicated in "Lubricating Points".

Apply the lubricant.

Maintenance

Lubricating Points

Apply lubricant at the following locations every 50 hours of operation.

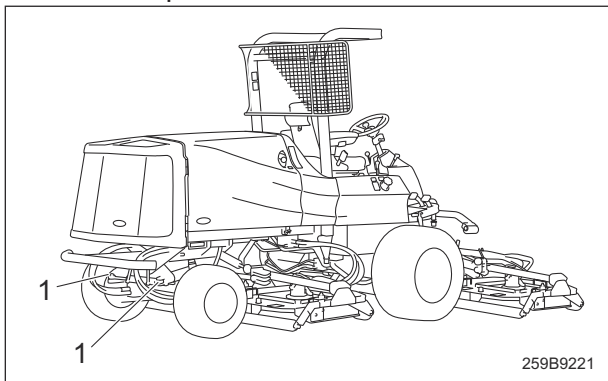

Lubricating Points_001

	Location	No. of lubricating points
1	Steering cylinder spherical bearing	2

1. Steering cylinder spherical bearing
There are two locations.

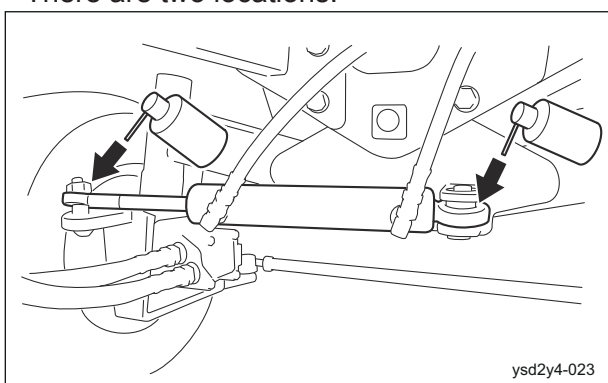

Lubricating Points_002

Adjustment

Engine

Adjustment of Fan Belt



Warning
Be sure to stop the engine before inspecting or adjusting the fan belt.



Warning
If a cover is removed due to inspection or adjustment, be sure to reinstall it in its original location.

Important

A slacking or damaged fan belt will cause overheating or lack of battery charge. Adjust or replace the belt.

For fan belt adjustment, follow either of the methods below.

1. Adjustment on the basis of belt slack deviation when applying a specified load to a specified place
 - [1] Press the middle of the belt with your finger to check the belt tension. The belt tension is appropriate when the belt slacks by approximately 10 - 12 mm (0.39 - 0.47 in) when you apply a force of 98 N (10 kgf) to the belt at the middle point between the pulleys.
 - [2] If the belt tension is inappropriate, loosen bolts A and B for securing the alternator, and then move the alternator to adjust the tension.
 - [3] Be sure to tighten the bolts A and B securely after adjustment.
 - [4] After adjustment of belt tension, check the belt tension again. If the belt tension is still not at the appropriate value after repeating the adjustment several times, replace the belt with a new one.

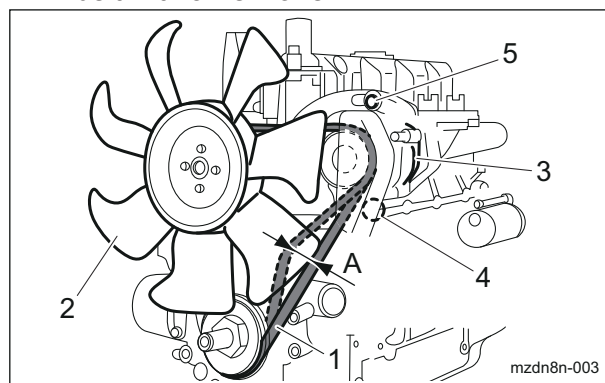

Adjustment of Fan Belt_001

1	Fan belt
2	Blade
3	Alternator
4	Bolt A
5	Bolt B
A	10 - 12 mm (0.39 - 0.47 in)

2. Adjustment to suitable belt tension force by using sonic type tension meters at a specified point

Important

Perform correct measurement in accordance with the operations manual of the equipment being used for tension measurement.

Important

Perform measurement immediately after mounting the belt, when the pulley is not rotating.

- [1] Measure belt tension force by using a sonic type tension meter.
For measurement position and distance between pulleys, see diagram below.
Here is the suitable belt tension force.

Adjustment	237 - 403 N (24.17 - 41.09 kgf)
Replacement	460 - 680 N (46.91 - 69.34 kgf)

- [2] If the belt tension is inappropriate, loosen bolts A and B for securing the alternator, and then move the alternator to adjust the tension.
- [3] Be sure to tighten the bolts A and B securely after adjustment.
- [4] After adjustment of belt tension, check the belt tension again.
If the belt tension is still not at the appropriate value after repeating the adjustment several times, replace the belt with a new one.

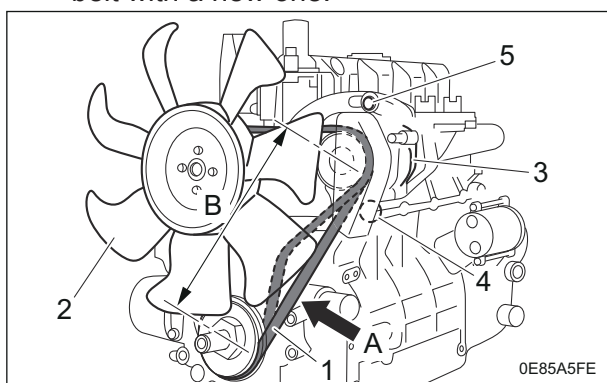

Adjustment of Fan Belt_002

1	Fan belt
2	Blade
3	Alternator
4	Bolt A
5	Bolt B
A	Measurement position
B	Distance between pulleys

Mower Deck

Adjustment of Cutting Height

■Cutting Height Table

The adjustment range for the cutting height is 20.0 - 91.5 mm (0.79 - 3.60 in).

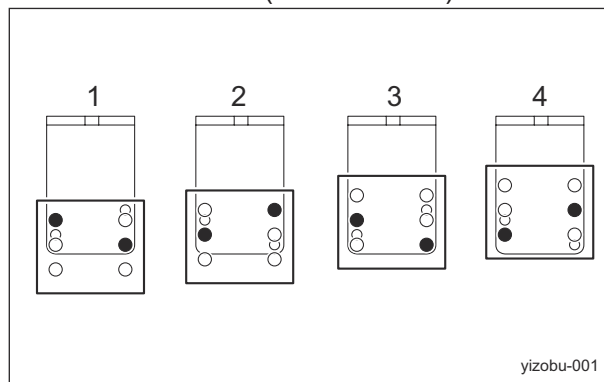

Cutting Height Table_001

1	Adjusting plate position 1
2	Adjusting plate position 2
3	Adjusting plate position 3
4	Adjusting plate position 4

Maintenance

Adjusting Plate Position	1	2	3	4
Adjusting Collars Inserted Under Cutting Height Adjusting Plate (Qty)	Cutting Height			
0	20.0 mm (0.79 in)	30.0 mm (1.18 in)	45.5 mm (1.79 in)	55.5 mm (2.19 in)
1	26.0 mm (1.02 in)	36.0 mm (1.42 in)	51.5 mm (2.03 in)	61.5 mm (2.42 in)
2	32.0 mm (1.26 in)	42.0 mm (1.65 in)	57.5 mm (2.26 in)	67.5 mm (2.66 in)
3	38.0 mm (1.50 in)	48.0 mm (1.89 in)	63.5 mm (2.50 in)	73.5 mm (2.89 in)
4	44.0 mm (1.73 in)	54.0 mm (2.13 in)	69.5 mm (2.74 in)	79.5 mm (3.13 in)
5	50.0 mm (1.97 in)	60.0 mm (2.36 in)	75.5 mm (2.97 in)	85.5 mm (3.67 in)
6	56.0 mm (2.20 in)	66.0 mm (2.60 in)	81.5 mm (3.21 in)	91.5 mm (3.60 in)

Note:

The factory default cutting height is 48.0 mm (1.89 in).

■ Adjustment with Adjusting Collars

Adjusting collars are installed at three locations on each mower deck.

Important

The length of grass cut off at any one time must be no more than 30.0 mm (1.18 in).

Important

Do not cut off more than 1/3 of the grass height.

1. Apply the parking brake, and then lower all mower decks.
2. Stop the engine, and then remove the key.

3. Loosen the nuts securing the adjusting collars at the three locations.

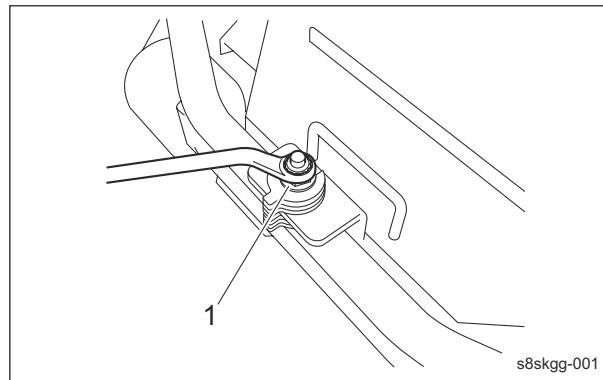

Adjustment with Adjusting Collars_001

1	Nut
---	-----

4. Refer to the Cutting Height Table, and then adjust the number of adjusting collars at the three locations.

[1] To increase cutting height:

Remove an upper adjusting collar and insert it below.

[2] To decrease cutting height:

Remove a lower adjusting collar and insert it above.

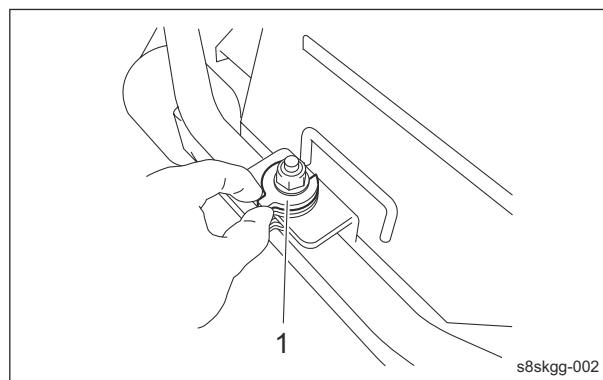

Adjustment with Adjusting Collars_002

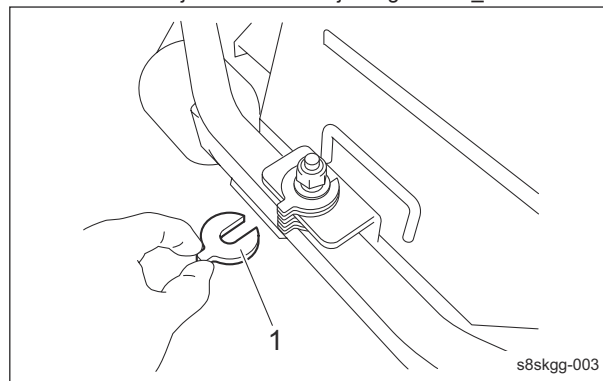

Adjustment with Adjusting Collars_003

1	Adjusting collar
---	------------------

5. After adjusting the adjusting collars at the three locations, firmly tighten all nuts.

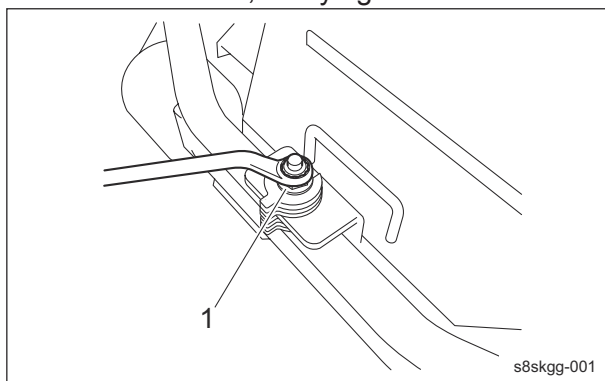

Adjustment with Adjusting Collars_004

1	Nut
---	-----

■ Adjustment with Cutting Height Adjusting Plates

Cutting height adjusting plates are installed at three locations on each mower deck.

Important

The length of grass cut off at any one time must be no more than 30.0 mm (1.18 in).

Important

Do not cut off more than 1/3 of the grass height.

1. Apply the parking brake, and then lower all mower decks.
2. Stop the engine, and then remove the key.
3. Loosen the six bolts securing the cutting height adjusting plates at the three locations on the mower deck.

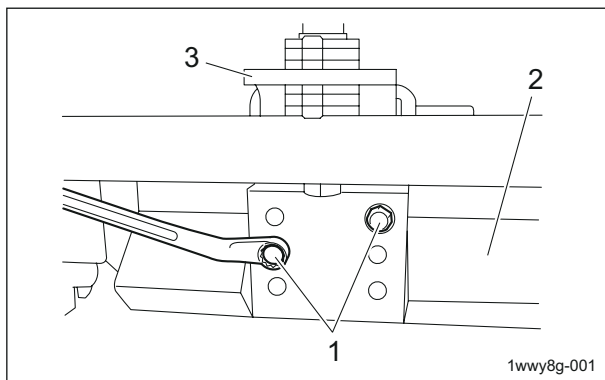

Adjustment with Cutting Height Adjusting Plates_001

1	Bolt
2	mower deck
3	Cutting height adjusting plate

4. Refer to the Cutting Height Table, and then change the hole positions.

[1] To increase cutting height:

- a. While lifting the handle at each location on the mower deck, remove the two bolts.
- b. Raise the mower deck to change the hole positions, and then temporarily secure it with the two bolts.

[2] To decrease cutting height:

- a. While lifting the handle at each location on the mower deck, remove the two bolts.
- b. Lower the mower deck to change the hole positions, and then temporarily secure it with the two bolts.

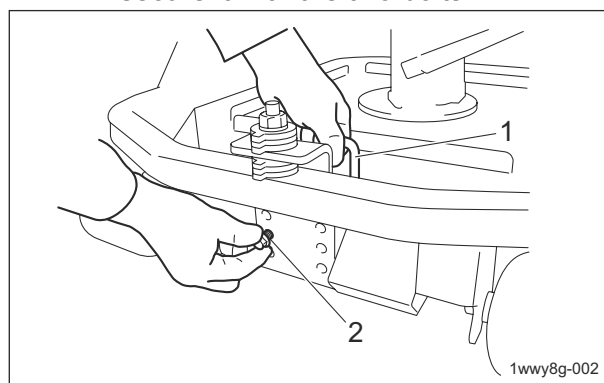

Adjustment with Cutting Height Adjusting Plates_002

1	Handle
2	Bolt

5. After making adjustments at the three locations, firmly tighten all bolts.

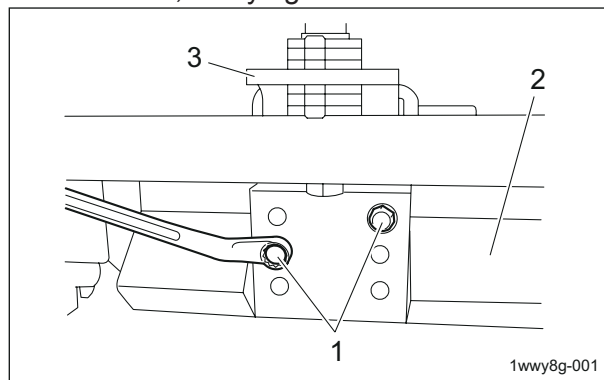

Adjustment with Cutting Height Adjusting Plates_003

1	Bolt
2	mower deck
3	Cutting height adjusting plate

Maintenance

Grinding of Rotary Knife

⚠ Caution

The rotary knife is an edged tool. Take extra care in handling since they could cut your hands or legs.

⚠ Caution

Wear gloves when touching edged tools to avoid cutting your hands.

⚠ Caution

If the rotary knife becomes worn or damaged, cracks or tears will occur between the sail and flat part. Broken pieces of the rotary knife may fly out while it is rotating.

⚠ Caution

When grinding the rotary knife, be sure to wear safety glasses and gloves.

Important

Using an imbalanced rotary knife will cause vibrations, resulting in damage to the machine.

When the edge of the rotary knife becomes rounded and no longer cuts well, sharpen the worn cutting edge with a grinder or sander. If the edge of the rotary knife becomes chipped or thin, replace it with a new one. The criteria for grinding the rotary knife are described below.

1. When, after grinding, the width of the rotary knife to the blade edge is $\frac{2}{3}$ or more of the total width of a new knife

2. When, after grinding, the blade base of the rotary knife does not reach the sail

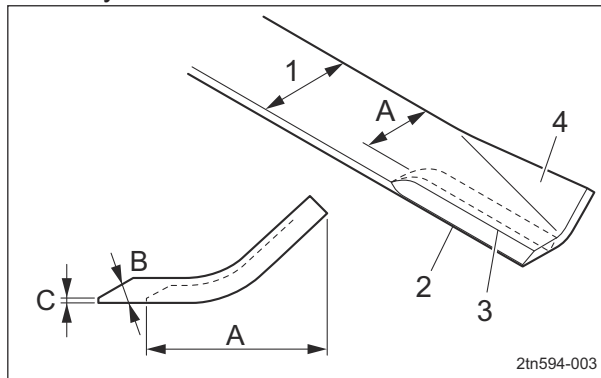

Grinding of Rotary Knife_001

1	Total width
2	Blade edge
3	Blade base
4	Sail
A	$\frac{2}{3}$ or more
B	30 - 40 °
C	0.5 - 1.0 mm (0.02 - 0.04 in)

3. When the thinnest part of the rotary knife has a thickness of $\frac{1}{3}$ or more of the thickness of a new knife

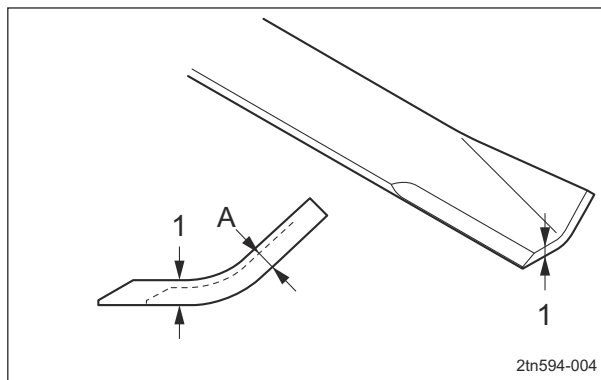

Grinding of Rotary Knife_002

1	Thickness
A	$\frac{1}{3}$ or more

Follow the steps below to grind the rotary knife.

1. Remove the rotary knife from the mower deck.

"Replacement of Rotary Knife" (Page 6-32)

Important

Grind only the top surface of the edge, and be sure to maintain the original angle.

By equally grinding the left and right ends of the rotary knife, it can be sharpened without becoming imbalanced.

2. Grind the cutting edge of the rotary knife. Grind so that the edge angle is 30 - 40 degrees, the point thickness is 0.5 - 1.0 mm (0.02 - 0.04 in), and the blade base does not reach the sail.

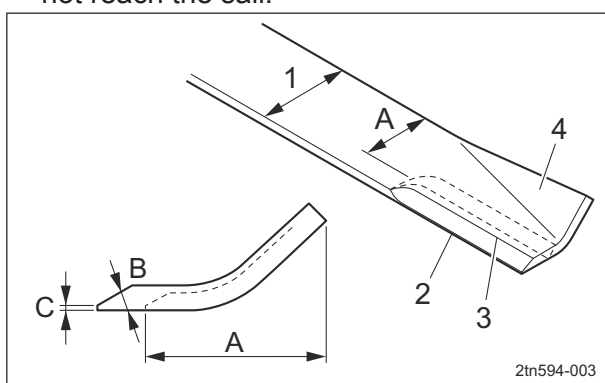

Grinding of Rotary Knife_003

1	Total width
2	Blade edge
3	Blade base
4	Sail
A	2/3 or more
B	30 - 40 °
C	0.5 - 1.0 mm (0.02 - 0.04 in)

3. Balance the rotary knife.

"Balancing of Rotary Knife" (Page 6-21)

4. If it is not balanced, repeat steps 2. - 3.

Balancing of Rotary Knife

Caution

The rotary knife is an edged tool. Take extra care in handling since they could cut your hands or legs.

Caution

When touching edged tools, wear gloves since they could cut your hands.

Important

Using an imbalanced rotary knife will cause vibrations, resulting in damage to the machine.

When the rotary knife is worn asymmetrically, causing vibrations, or when it becomes dull or worn, remove the rotary knife from the mower deck and balance it.

Follow the steps below to balance the rotary knife.

1. Remove the rotary knife from the mower deck.
"Replacement of Rotary Knife" (Page 6-32)
2. Install the balancer equipment in an appropriate location.
3. Fit the hole at the center of the rotary knife onto the balancer equipment, and then balance the left and right ends so that the rotary knife is level.

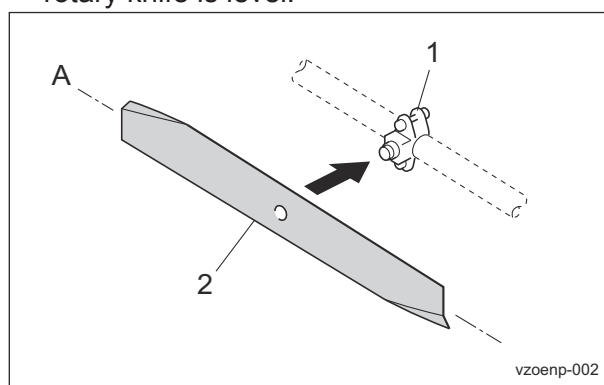

Balancing of Rotary Knife_001

1	Balancer equipment
2	Rotary knife
A	Level

Maintenance

Replacement

Engine

Replacement of Engine Oil

Caution

Be careful with hot oil, which could cause burns if it contacts your skin.

Important

When you change the engine oil, be sure to drain it into a bowl and discard it in accordance with local laws and regulations.

Important

Be sure to use engine oil that is classified as API Service Grade CF or higher, with an SAE Viscosity that is appropriate for the operating environment (ambient temperature).

Important

Securely install the oil level gauge and oil filler cap.

Change the engine oil more frequently if the engine oil is contaminated, and especially if you use the machine in dusty areas or operate the engine at high loads or in high temperatures.

1. Move the machine onto a level surface and stop the engine.
2. Remove the drain plug while the engine oil is warm, and then drain the oil into a bowl.
3. Re-place the drain plug in the engine.

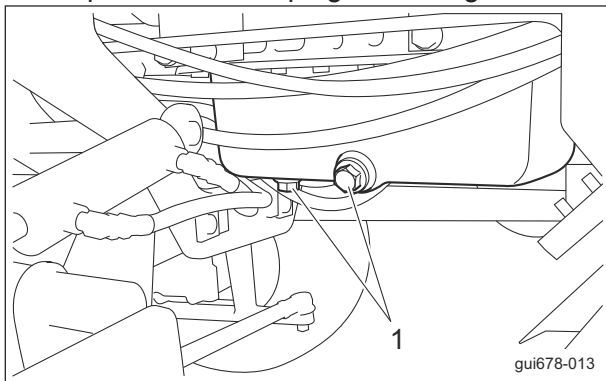

Replacement of Engine Oil_001

1	Drain plug
---	------------

4. Remove the oil filler cap, and supply new engine oil until the oil reaches a level in between the upper and lower limit lines on the oil level gauge.

There are two oil filling ports on the engine. Use either one.

Engine oil quantity is approximately 9.7 dm³ (9.7 L).

5. Install the oil filler cap.



Replacement of Engine Oil_002

1	Oil level gauge
2	Oil filler cap

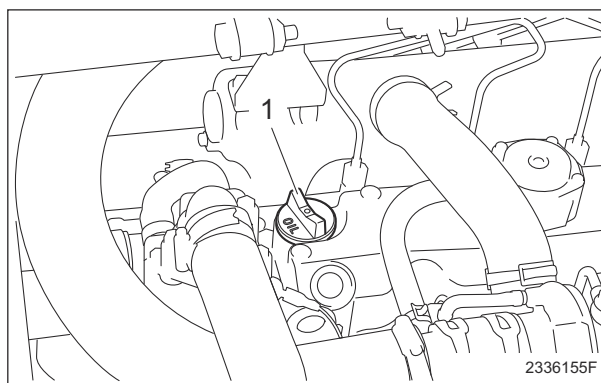

Replacement of Engine Oil_003

1	Oil filler cap
---	----------------

6. It will take a while for the supplied engine oil to descend into the oil pan. Check the oil level again 10 to 20 minutes after supplying the oil.
7. Check underneath the machine for oil leakage.

Replacement of Engine Oil Filter

Caution

Be careful with hot oil, which could cause burns if it contacts your skin.

Important

When replacing the engine oil filter, be sure to drain the engine oil into a container and discard it in accordance with local laws and regulations.

Important

Be sure to use engine oil that is classified as API Service Grade CF or higher, with an SAE Viscosity that is appropriate for the operating environment (ambient temperature).

Important

Securely install the oil level gauge and oil filler cap.

1. With the filter wrench, remove the old filter cartridge.

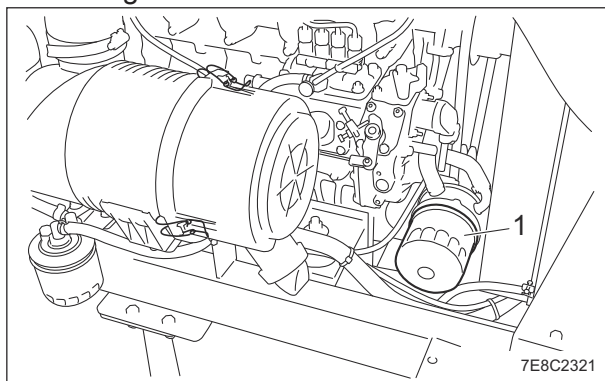

Replacement of Engine Oil Filter_001

1	Filter cartridge
---	------------------

2. Lightly coat the packing of the new filter cartridge with engine oil.
3. Hand-tighten the filter cartridge until the packing contacts the sealing surface, and then firmly hand-tighten (without using a filter wrench).
4. Supply engine oil until it reaches the specified level.
"Supply of Engine Oil" (Page 6-8)
5. Start the engine, and then stop it after 10 to 20 minutes.

6. Make sure that there is no oil leakage at the sealing surface of the filter cartridge.
7. Check the engine oil level.
If it is low, supply engine oil until it reaches the specified level.

Replacement of Fuel Filter

Important

When installed, be careful that it is not contaminated with dirt or dust. If the fuel is contaminated with dirt or dust etc., the fuel injection pump and injection nozzle will become worn.

Since the fuel filter is a cartridge, it cannot be disassembled or cleaned. If dust or dirt accumulates in the fuel filter, the fuel flow will become insufficient. Replace the fuel filter at the appropriate times.

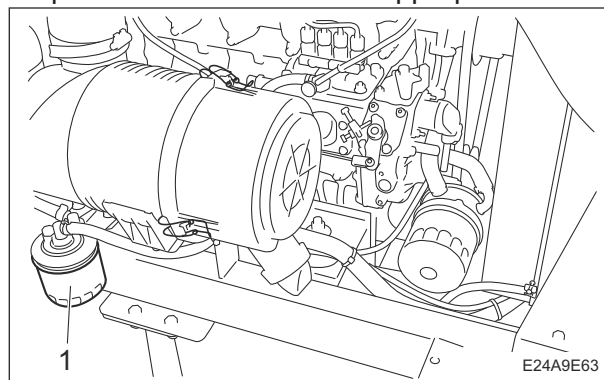

Replacement of Fuel Filter_001

1	Fuel filter
---	-------------

1. Follow the steps below to replace the fuel filter.
[1] Using a filter wrench, remove the fuel filter cartridge.

Maintenance

- [2] Lightly apply fuel to the packing of the new cartridge, and then properly hand-tighten the cartridge, without using the filter wrench.

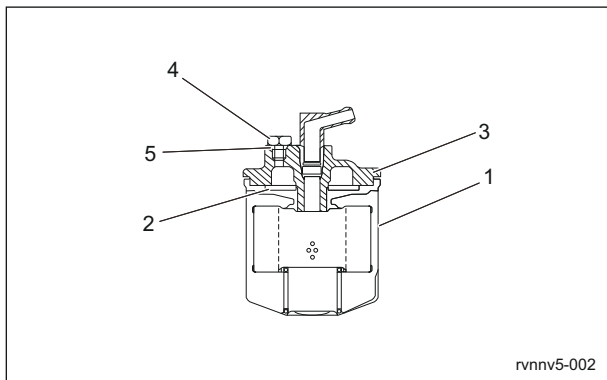

Replacement of Fuel Filter_002

1	Cartridge
2	Packing
3	Cover
4	Air-bleeding plug
5	O-ring

2. If the key is turned to the "ON" position and the fuel pump is operated after replacement, air bleeding will occur automatically.

Replacement of Air Cleaner Element

Important

A contaminated air cleaner element may cause malfunction of the engine.

- The timing for replacing the air cleaner element is described below.
 - [1] Replace the air cleaner element in accordance with the Maintenance Schedule.
 - [2] If it is significantly contaminated, replace it, even if the hours of operation do not exceed the specified time.
- Replace the air cleaner element by following the same steps as for cleaning the air cleaner element.
"Cleaning of Air Cleaner Element" (Page 6-4)

Replacement of Coolant

Caution

Do not touch the radiator or coolant during engine operation or immediately after the engine has been turned off. Otherwise, you may get burned.

Caution

Change coolant after the engine has well cooled down.

Caution

The radiator cap is pressurized. If you remove the radiator cap while the engine is overheated, hot steam will burst out, possibly resulting in burns. Make sure that the water temperature and pressure are reduced, and then grab the cap with a thick cloth and gradually open the cap.

Important

When changing the coolant, be sure to drain it into a container and discard it in accordance with local laws and regulations.

Important

When changing the coolant, be sure to mix clean water and antifreeze (long-life coolant), and then pour it into the radiator and reserve tank.

Important

Tightly close the radiator cap. If the cap is loose or incorrectly installed, the engine will be overheated due to water leakage, resulting in engine damage.

When mixing antifreeze and clean water, refer to "Relationship between concentration of long-life coolant (LLC) and freezing temperature" below for the mixing ratio.

Relationship between concentration of long-life coolant (LLC) and freezing temperature

Freezing temperature	LLC concentration (volume %)
Down to -10 °C (14 °F)	20 %
Down to -15 °C (5 °F)	30 %
Down to -20 °C (-4 °F)	35 %
Down to -25 °C (-13 °F)	40 %

1. Stop the engine, and then allow the radiator to cool.
2. Open the hood.
3. Follow the steps below to drain the coolant.
 - [1] Position a container to drain the coolant into.
 - [2] Remove the drain plug from the radiator.

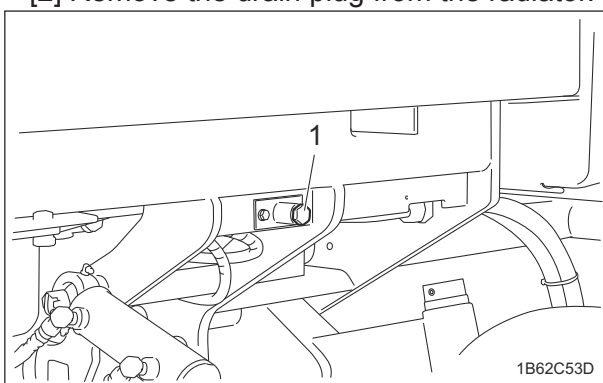

Replacement of Coolant_001

1	Radiator drain plug
---	---------------------

- [3] Remove the radiator cap.
- [4] Remove the reserve tank.
- [5] Open the reserve tank cap, and then drain the coolant.

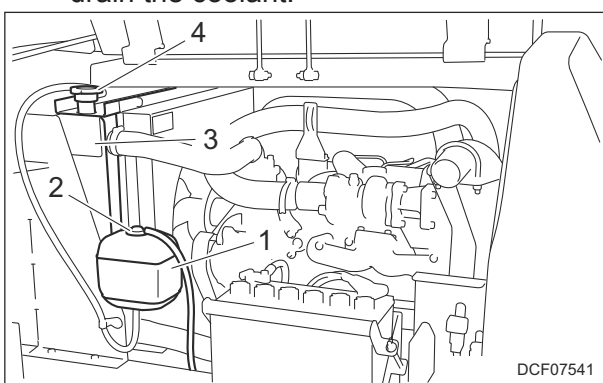

Replacement of Coolant_002

1	Reserve tank
2	Reserve tank cap
3	Radiator
4	Radiator cap

4. Install the reserve tank.
5. Clean the radiator with clean water to remove any debris or rust.
6. Drain all water from the radiator.
7. Follow the steps below to fill with coolant. The coolant quantity, including the reserve tank, is 12.0 dm³ (12.0 L).
 - [1] Install the drain plug.
 - [2] Supply clean water and antifreeze into the radiator up to the radiator cap opening.
 - [3] Close the radiator cap.
 - [4] Supply clean water and antifreeze into the reserve tank up to the "FULL" mark.
 - [5] Close the reserve tank cap.
8. Start the engine, and then idle for several minutes to bleed air from the system.
9. Stop the engine, and then allow the radiator to cool.
10. Check if the coolant level in the reserve tank is between "FULL" and "LOW", and then supply coolant if necessary.
11. Close the hood.

Maintenance

Main Vehicle

Replacement of Hydraulic Oil

⚠ Caution

Be careful with hot oil, which could cause burns if it contacts your skin.

Important

When you change the hydraulic oil, be sure to drain it into a bowl and discard it in accordance with local laws and regulations.

Important

If the oil emulsifies or if it becomes even slightly less transparent, change the oil immediately.

Important

For the hydraulic oil to be used, consult Characteristics of Hydraulic Oil and use the oil whose characteristics are equivalent or superior to those specified there. Especially regarding kinematic viscosity and viscosity index, use of hydraulic oil whose figures are less than those of the specified hydraulic oil will cause a malfunction in the hydraulic circuit.

■ Characteristics of Hydraulic Oil

ISO Viscosity Grade		ISO VG46
Density	15 °C (59 °F)	0.873 g/cm ³ (0.0315 lb/in ³)
API Gravity		30.6
Flash Point (Open Cup)		230 °C (446 °F)
Pour Point		-30 °C (-22 °F)
Kinematic	40 °C (104 °F)	46 mm ² /s (46 cSt)
Viscosity	100 °C (212 °F)	7 mm ² /s (7 cSt)
Viscosity Index		109

■ Characteristics of Hydraulic Oil with conditions of use

Hydraulic oil of ISO viscosity grade VG68 can be used only if the following condition is met:

- The outside temperature must be 20 °C (68 °F) or more during engine operation.

ISO Viscosity Grade		ISO VG68
Density	15 °C (59 °F)	0.878 g/cm ³ (0.0318 lb/in ³)
API Gravity		29.7
Flash Point (Open Cup)		252 °C (486 °F)
Pour Point		-30 °C (-22 °F)
Kinematic	40 °C (104 °F)	68 mm ² /s (68 cSt)
Viscosity	100 °C (212 °F)	9 mm ² /s (9 cSt)
Viscosity Index		107

Note:

In Japan, "Shell Tellus S2M46 (ISO VG46)" and "Shell Tellus S2M68 (ISO VG68)" meet the characteristics described above.

However, in other countries, the specification of Shell Tellus S2M46 and Shell Tellus S2M68 can be below what is required.

Please check the product data sheet to ensure that it meets the requirements before using.

1. Follow the steps below to remove the old oil.

[1] Start and run the engine to warm up the oil.

[2] Lower the mower decks on a level surface, and then stop the engine.

[3] Remove the drain plug of the hydraulic tank, and then drain the old oil into a container.

[4] Wind new sealing tape on the drain plug, and then attach it to the hydraulic tank.

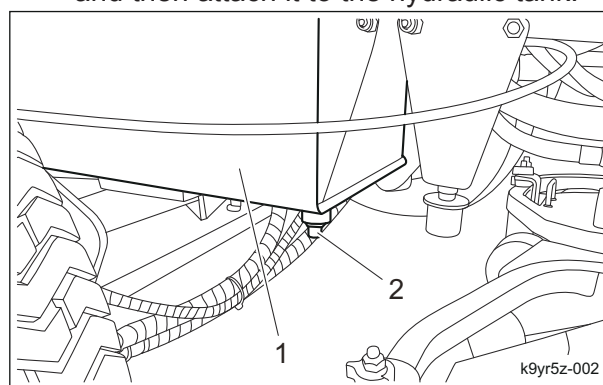

Replacement of Hydraulic Oil_001

1	Hydraulic tank
2	Drain plug

2. Remove the left tank cover.

3. Follow the steps below to supply new oil.

The hydraulic tank capacity is approximately 44.0 dm³ (44.0 L).

■ #20001 - 20071

- [1] Open the tank cap.
- [2] Supply hydraulic oil through the oil filling port until the oil level reaches the middle of the oil gauge on the hydraulic tank.
- [3] Tighten the tank cap securely.

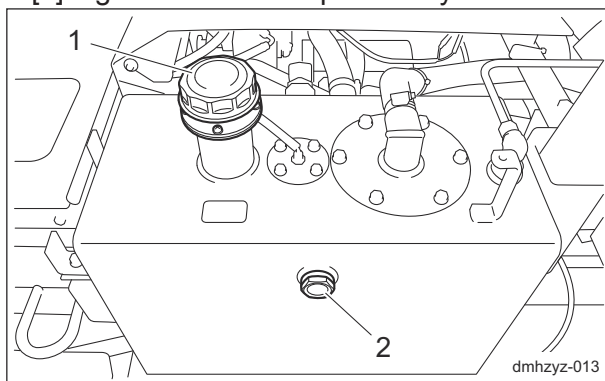

Replacement of Hydraulic Oil_002

1	Tank cap
2	Oil gauge

■ #20072-

- [1] Loosen the bushing with a wrench and remove the oil filler plug.
- [2] Supply hydraulic oil through the oil filling port until the oil level reaches the middle of the oil gauge on the hydraulic tank.
- [3] Install the oil filler plug and tighten the bushing securely.

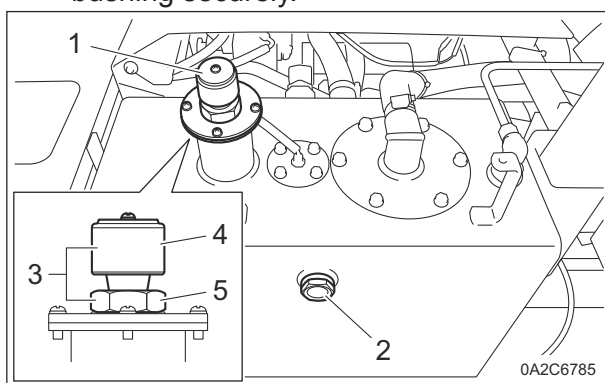

Replacement of Hydraulic Oil_003

1	Tank cap
2	Oil gauge
3	Oil filler plug
4	Air breather
5	Bushing

4. Start the engine, and then repeat the steps below a few times.

- Raise and lower the mower units.
- Turn the steering wheel left and right.
- Move forward and reverse.

5. Lower the mower decks and maintain that position on a level surface, check to see if the oil level is at the middle of the oil gauge. If the hydraulic oil level is low, supply oil again until it reaches the specified level.

6. Check underneath the machine for oil leakage.

7. Install the left tank cover.

Maintenance

Replacement of Hydraulic Oil Filter

■ Replacement of Hydraulic Oil Line Filter

⚠ Caution

Be careful with hot oil, which could cause burns if it contacts your skin.

Important

When replacing the hydraulic oil filter, be sure to drain the oil into a container and discard it in accordance with local laws and regulations.

Important

If the hydraulic oil emulsifies or if it becomes even slightly less transparent, change the oil immediately.

Important

Use hydraulic oil whose specification meets the requirements.

1. Lower the mower decks on a level surface, and then stop the engine.
2. Remove the filter protection plate.

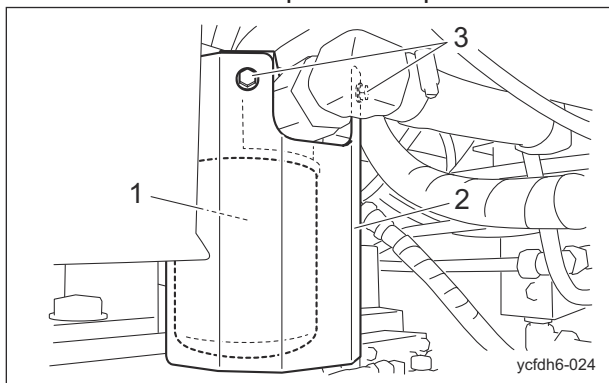

Replacement of Hydraulic Oil Line Filter_001

1	Filter cartridge
2	Filter protection plate
3	Bolt

3. Loosen the old filter cartridge by hand and remove it.
4. Lightly coat the packing of the new filter cartridge with hydraulic oil, and then install the cartridge.

5. Firmly tighten the filter cartridge by hand until the packing contacts the mounting surface.
And then tighten it with a half more turn.

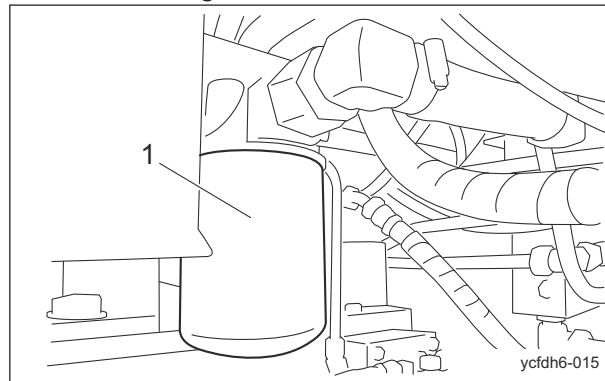

Replacement of Hydraulic Oil Line Filter_002

1	Filter cartridge
---	------------------

6. Supply hydraulic oil until it reaches the specified level.
"Supply of Hydraulic Oil" (Page 6-10)
7. Start the engine and stop it after hydraulic oil warmed.
8. Check underneath the machine for hydraulic oil leakage.
9. Install the filter protection plate.

■ Replacement of Hydraulic Oil Suction Filter

⚠ Caution

Be careful with hot oil, which could cause burns if it contacts your skin.

Important

When replacing the hydraulic oil filter, be sure to drain the oil into a container and discard it in accordance with local laws and regulations.

Important

If the hydraulic oil emulsifies or if it becomes even slightly less transparent, change the oil immediately.

Important

Use hydraulic oil whose specification meets the requirements.

Important

Replace the intake port packing with a new one.

1. Lower the mower decks on a level surface, and then stop the engine.
2. Remove the left tank cover.
3. Remove bolts, spring washers and washers, and then remove the intake hose joint fitting.
4. Remove the old suction filter and intake port packing.
5. Remove all of the old liquid gasket from the hydraulic tank.
6. Remove all of the old liquid gasket and the intake port packing from the intake hose joint fitting.
7. Wash and clean the intake hose joint fitting.
8. Apply liquid gasket to the new intake port packing and then install it to the intake hose joint fitting.
9. Install the new suction filter to the intake hose joint fitting.

10. Install the intake hose joint fitting to the hydraulic tank.

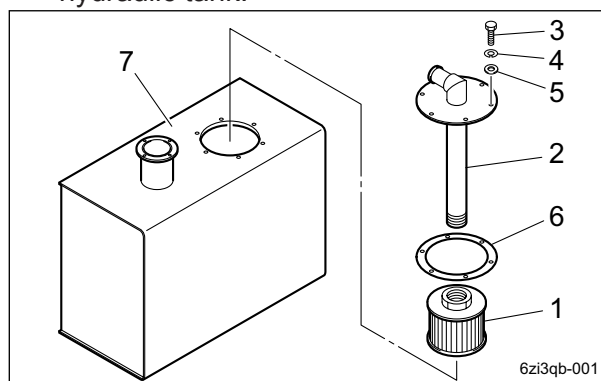

Replacement of Hydraulic Oil Suction Filter_001

1	Suction filter
2	Intake hose joint fitting
3	Bolt
4	Spring washer
5	Washer
6	Intake port packing
7	Hydraulic tank

11. Supply hydraulic oil until it reaches the specified level.
"Supply of Hydraulic Oil" (Page 6-10)
12. Start the engine and stop it after hydraulic oil warmed.
13. Check underneath the machine for hydraulic oil leakage.
14. Install the left tank cover.

Maintenance

Replacement of Air Breather Element

Caution

Be careful with hot oil, which could cause burns if it contacts your skin.

#20072-

1. Lower the mower decks on a level surface, and stop the engine.
2. Remove the left tank cover.
3. Loosen the air breather screw and remove the seal washer.

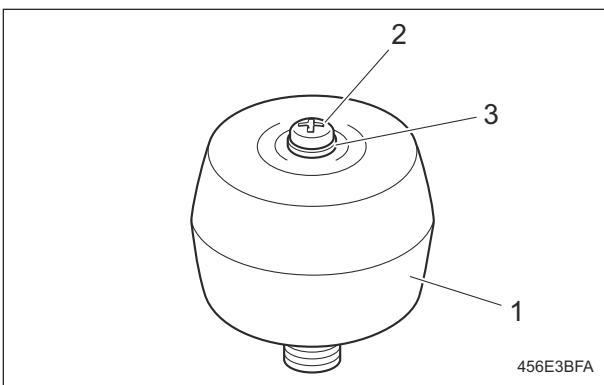

Replacement of Air Breather Element_001

1	Air breather
2	Screw
3	Seal washer

4. Remove the top cover of the air breather.
5. Remove the old element.

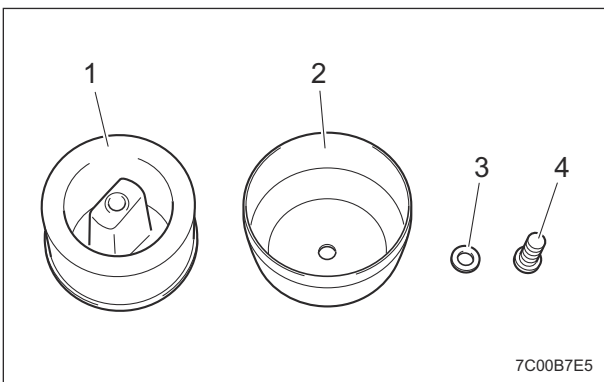

Replacement of Air Breather Element_002

1	Element
2	Top cover
3	Seal washer
4	Screw

6. Install the new element.

Important

If the seal washer is damaged, replace it with a new one.

7. Install the top cover of the air breather.
8. Install the seal washer and tighten the screw.
9. Install the left tank cover.

Replacement of Resin Bushing

Resin bushings are installed in the following locations.

Replace resin bushings according to the maintenance schedule.

1. Lift arm (#1, #4, #5)

Note:

The illustration shows the lift arm #4.

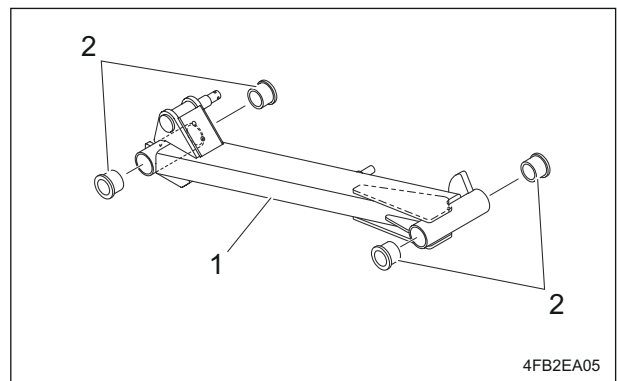

Replacement of Resin Bushing_001

1	Lift arm
2	Resin bushing

2. Lift arm (#2, #3)

Note:

The illustration shows the lift arm #2.

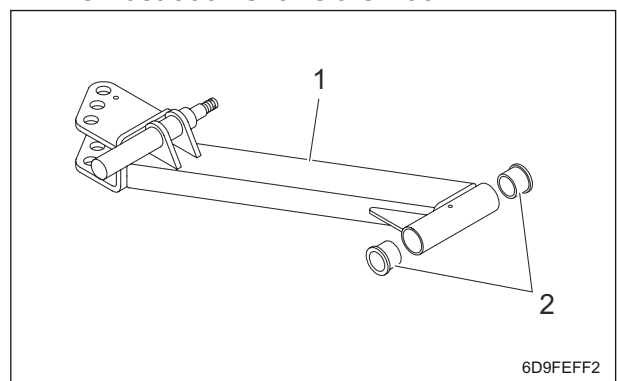

Replacement of Resin Bushing_002

1	Lift arm
2	Resin bushing

3. Swiveling bracket (#2, #3)

Note:

The illustration shows the swiveling bracket #2.

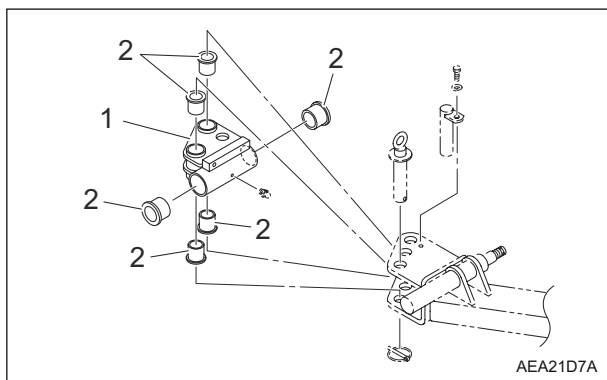

Replacement of Resin Bushing_003

1	Swiveling bracket
2	Resin bushing

4. Deck arm (#1, #2, #3, #4, #5)

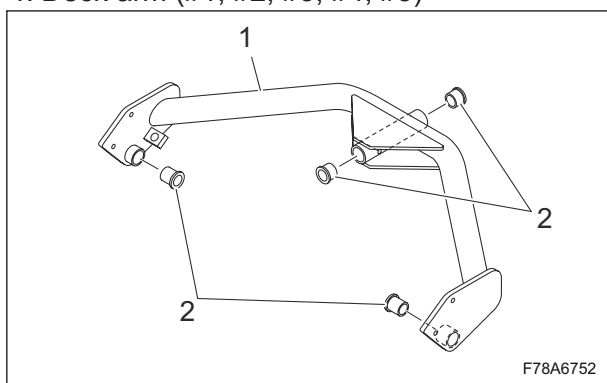

Replacement of Resin Bushing_004

1	Deck arm
2	Resin bushing

Replacement of Tires

■ Replacement of Front Tires

1. Removing front tires

Follow the steps below to remove the front tires:

[1] Loosen the bolts.

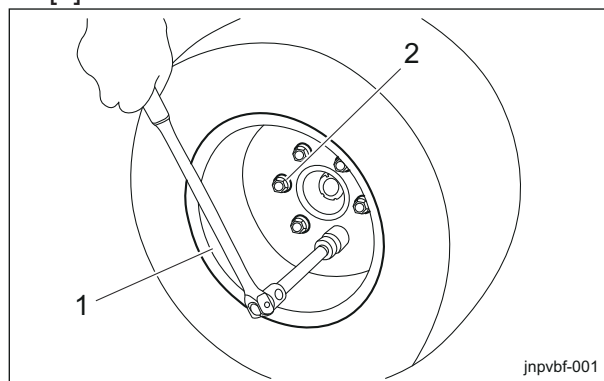

Replacement of Front Tires_001

1	Front tire
2	Bolt

[2] Securely place the jack beneath the jack-up point of the front left/right frame area, and then raise it until the tire lifts off the ground.

"Jack-Up Points" (Page 6-3)

[3] Remove the bolts.

[4] Remove the tire from the wheel mounting seat.

2. Installing front tires

Important

Tighten the bolts in the tightening order (crosswise).

Important

Tighten the wheel mounting bolts on the specified torque by using a torque wrench.

For installing the front tires, reverse the removing procedure.

Maintenance

■ Replacement of Rear Tire

1. Removing rear tires

Follow the steps below to remove the rear tire.

[1] Loosen the bolts.

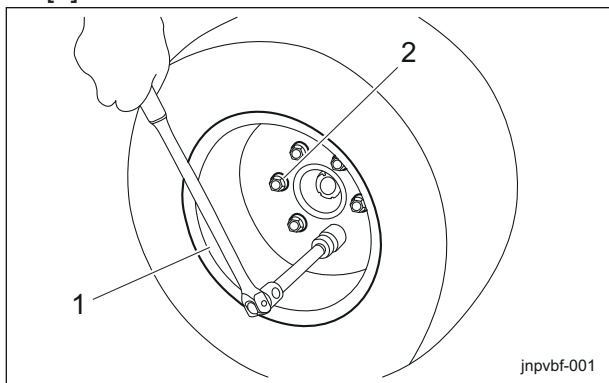

Replacement of Rear Tire_001

1	Rear tire
2	Bolt

[2] Securely place the jack beneath the jack-up point below the rear wheel motor, and then raise it until the tire lifts off the ground.

"Jack-Up Points" (Page 6-3)

[3] Remove the bolts.

[4] Remove the tire from the wheel mounting base.

2. Installing rear tires

Important

Tighten the bolts in the tightening order (diagonally).

Important

Tighten the wheel mounting bolts on the specified torque by using a torque wrench.

For installing the rear tire, reverse the removing procedure.

Mower Deck

Replacement of Rotary Knife

Caution

The rotary knife is an edged tool. Take extra care in handling since they could cut your hands or legs.

Caution

If the rotary knife becomes worn or damaged, cracks or tears will occur between the sail and flat part.

Broken pieces of the rotary knife may fly out while it is rotating.

Caution

Wear gloves when touching edged tools since they could cut your hands.

Important

The rotary knife has a specific installation direction.

Do not install it facing the wrong direction.

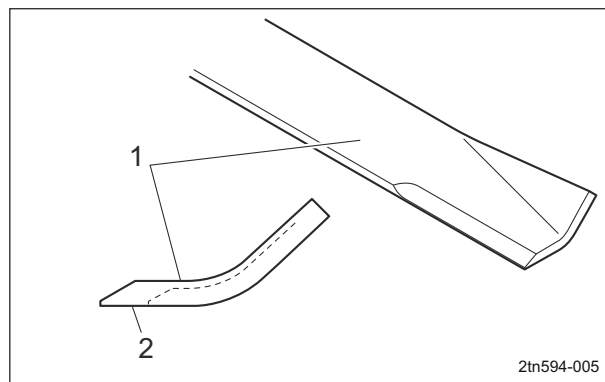

Replacement of Rotary Knife_001

1	Rotary knife top side
2	Rotary knife bottom side

Important

Before installing the rotary knife, make sure that it is balanced.

If the edge of the rotary knife becomes chipped or thin, replace it with a new one. The criteria for replacing the rotary knife are described below.

- When the narrowest part of the rotary knife has a width of less than $\frac{2}{3}$ of the width of a new knife

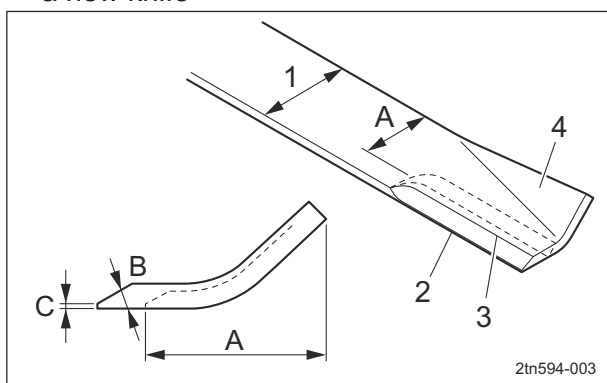

Replacement of Rotary Knife_002

1	Total width
2	Blade edge
3	Blade base
4	Sail
A	less than $\frac{2}{3}$
B	30 - 40 °
C	0.5 - 1.0 mm (0.02 - 0.04 in)

- When the thinnest part of the rotary knife has a thickness of less than $\frac{1}{3}$ of the thickness of a new knife

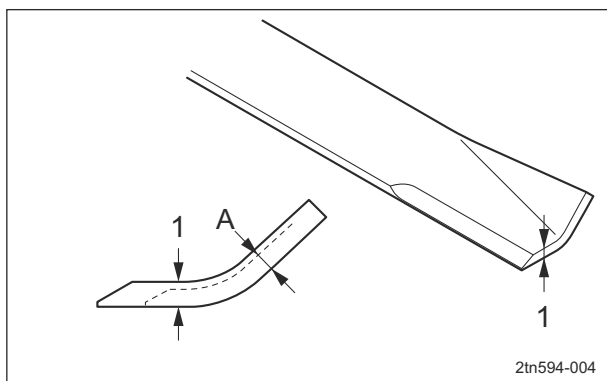

Replacement of Rotary Knife_003

1	Thickness
A	less than $\frac{1}{3}$

■Mower Deck #1

- Start the engine, and then raise the mower decks.
- Stop the engine, and then remove the key.
- Lift the mower deck at the front.

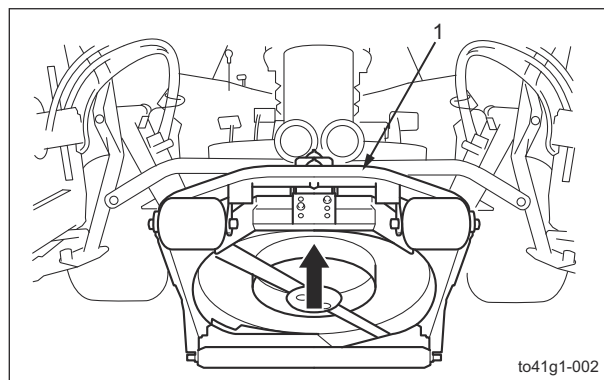

Mower Deck #1_001

1	Mower deck
---	------------

- Remove the cotter pin and hardened roundhead pin inserted at a, and then insert them at b.

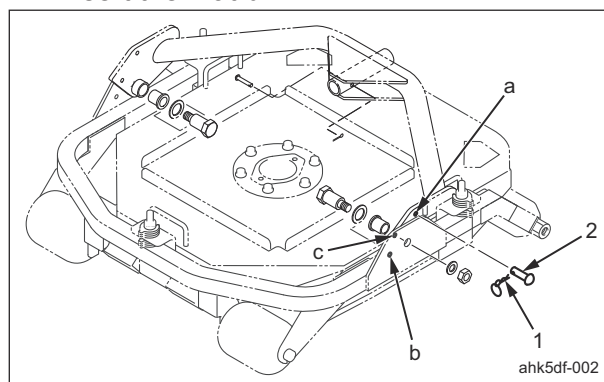

Mower Deck #1_002

1	Cotter pin
2	Hardened roundhead pin

- Follow the steps below to remove the rotary knife.

- [1] Use the square pipe from the included tools to secure the rotary knife so that it does not turn.
- [2] Remove the two bolts, spring washers and washers used to install the rotary knife.
- [3] Remove the knife guide.
- [4] Remove the rotary knife.

Maintenance

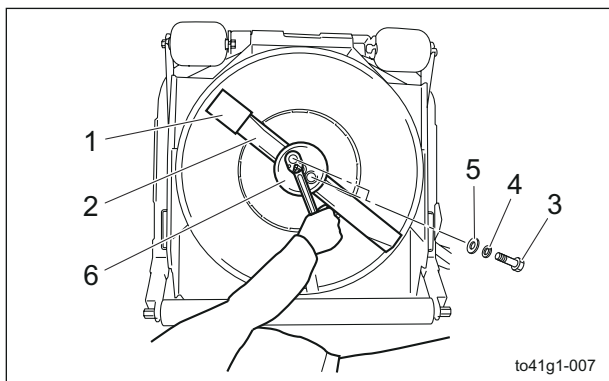

Mower Deck #1_003

1	Square pipe
2	Rotary knife
3	Bolt
4	Spring washer
5	Washer
6	Knife guide

Important

The tightening torque for the knife mounting bolt is 104 - 134 N-m (1,060.49 - 1,366.40 kgf-cm).

6. Install the rotary knife.
For installing the rotary knife, reverse the removing procedure.

■Mower Decks #2/#3

1. Swivel the mower deck.
2. Start the engine, and then raise the mower decks.
3. Stop the engine, and then remove the key.
4. Lift the mower deck at the front.

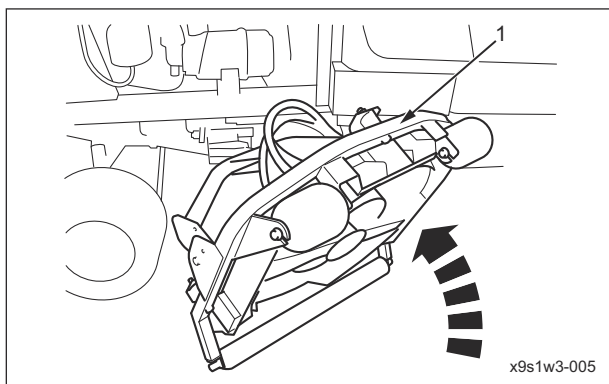

Mower Decks #2/#3_001

1	Mower deck
---	------------

5. Remove the cotter pin and hardened roundhead pin inserted at a, and then insert them at b.

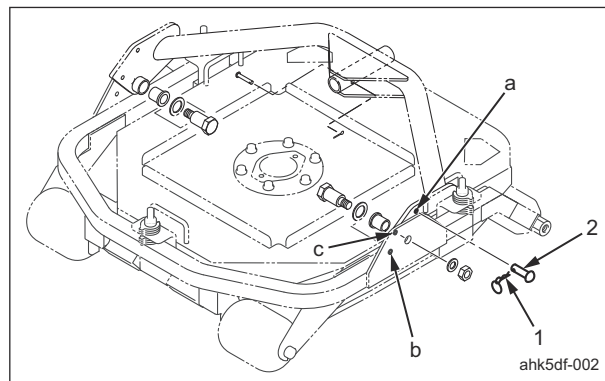

Mower Decks #2/#3_002

1	Cotter pin
2	Hardened roundhead pin

6. Follow the steps below to remove the rotary knife.
 - [1] Use the square pipe from the included tools to secure the rotary knife so that it does not turn.
 - [2] Remove the two bolts, spring washers and washers used to install the rotary knife.
 - [3] Remove the knife guide.
 - [4] Remove the rotary knife.

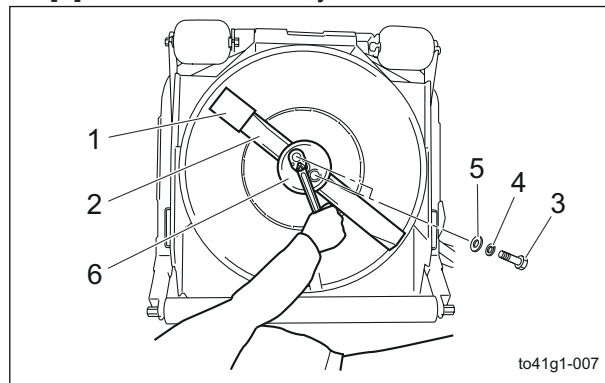

Mower Decks #2/#3_003

1	Square pipe
2	Rotary knife
3	Bolt
4	Spring washer
5	Washer
6	Knife guide

Important

The tightening torque for the knife mounting bolt is 104 - 134 N-m (1,060.49 - 1,366.40 kgf-cm).

7. Install the rotary knife.
For installing the rotary knife, reverse the removing procedure.

■ Mower Decks #4/#5

1. Start the engine, and then raise the mower decks.

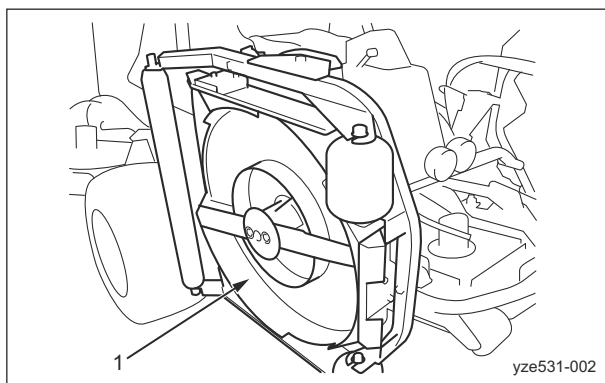

Mower Decks #4/#5_001

1	Mower deck
---	------------

2. Stop the engine, and then remove the key.
3. Remove the cotter pin and hardened roundhead pin inserted at a, and then insert them at c.

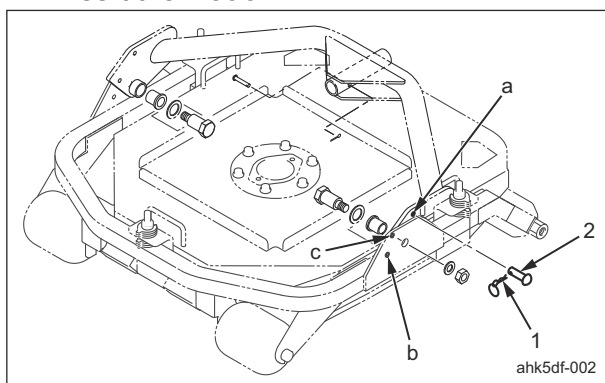

Mower Decks #4/#5_002

1	Cotter pin
2	Hardened roundhead pin

4. Follow the steps below to remove the rotary knife.

- [1] Use the square pipe from the included tools to secure the rotary knife so that it does not turn.
- [2] Remove the two bolts, spring washers and washers used to install the rotary knife.
- [3] Remove the knife guide.
- [4] Remove the rotary knife.

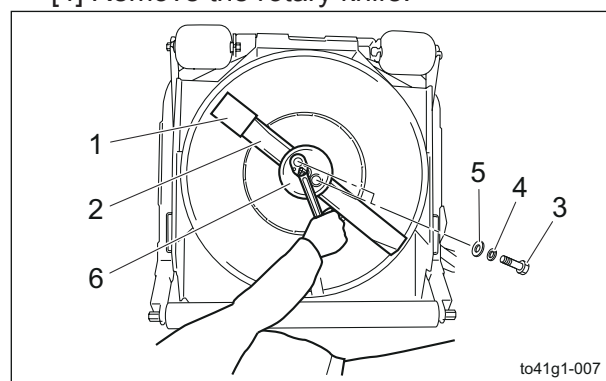

Mower Decks #4/#5_003

1	Square pipe
2	Rotary knife
3	Bolt
4	Spring washer
5	Washer
6	Knife guide

Important

The tightening torque for the knife mounting bolt is 104 - 134 N-m (1,060.49 - 1,366.40 kgf-cm).

5. Install the rotary knife.
For installing the rotary knife, reverse the removing procedure.

Storage

Long-Term Storage

Follow the instructions below for long-term storage of the machine.

1. Cleaning

- Remove dirt, grass clippings, oil stains etc. completely from the main vehicle and engine.

2. Replacing oil

- Inspect and replace the engine oil, hydraulic oil and element.

3. Greasing and lubricating

- Supply oil and apply grease to appropriate parts.

4. Battery

- Remove the negative battery wire.

5. Fuel

- Remove the fuel from the fuel tank.

6. Tire pneumatic pressure

- Set the tire air pressure slightly higher than normal, and then place the machine on a board to avoid humidity.

7. Mower decks

- When storing this machine, lower all the mower decks unless a positive mechanical lock is provided.

8. Storage location

- Cover the machine and store it in a dry place where it will not be exposed to rain.

Precautions for Repair Page 7-2

Adjustment Page 7-2

Adjustment of Brake Page 7-2

Adjustment of The Neutral Position
of The Piston Pump Page 7-4

Replacement Page 7-4

Replacement of Fuse Page 7-4

TowingPage 7-5

Towing The Machine in An
EmergencyPage 7-5

Repair

Precautions for Repair

Warning

The chapter "Repair" in this manual describes practical measures which should be performed by a mechanic with expertise. The owner should instruct the mechanic with expertise to perform repair service for this machine.

Caution

First, learn well the operations you plan to perform.

Important

Use tools appropriate for each operation.

Important

Use Barons genuine parts for replacement and accessories. Our product warranty may be void if you use non-genuine parts for replacement or accessories.

Adjustment

Adjustment of Brake

Caution

Make sure that the brake wire is not cracked or damaged.

Important

If the brake is not sufficiently effective due to a larger clearance between the brake disc and the pad, adjust the clearance. The wire is used for fine adjustments.

Important

Adjust the brake with the brake pads.

The brake pad wear limit is 3 mm (0.12 in).



Adjustment of Brake_001

1	Brake disc
2	Brake pad

Important

Make sure that the lever is maintained in the open position (neutral).

1. For each wheel, fully tighten the adjustment bolt on the brake disc side.

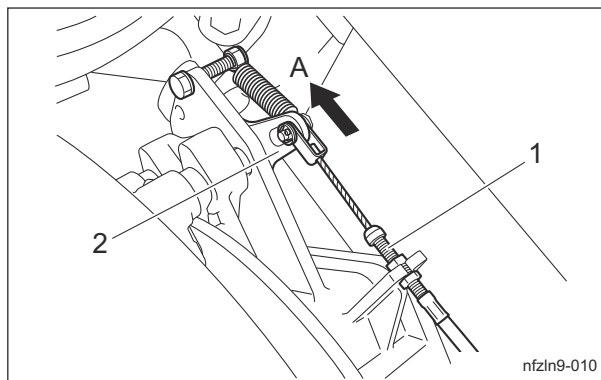

Adjustment of Brake_002

1	Adjustment bolt (on brake disc side)
2	Lever
A	Open (neutral)

- Reduce the clearance by loosening the lock nut, then tightening the adjustment nut. Tighten the adjustment nut until the friction material contacts the friction surface of the disc.

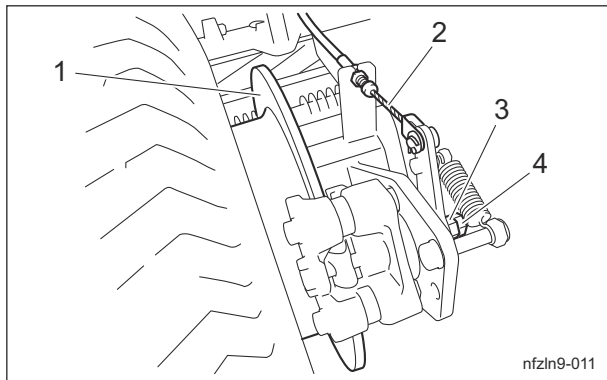

Adjustment of Brake_003

1	Brake disc
2	Wire
3	Adjustment nut
4	Lock nut

Warning

A clearance between the brake disc and the pad that is too small may result in heat generation or fire.

- Loosen the adjustment nut to adjust the clearance between the brake disc and the pad to about 0.2 mm (0.0079 in).
- Securely place the jack beneath the jack-up point of the front left/right frame area, and then raise it until both tires lift off the ground.
- Check that the disc rotates freely.
- Tighten the lock nut, and then fully tighten it while holding the adjustment nut in place.
- With the brake pedal released, obtain a play of 1 mm (0.039 in) at the connection of the inner wire.

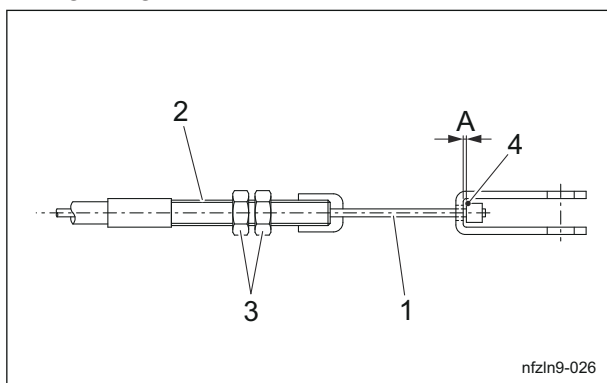

Adjustment of Brake_004

1	Inner wire
2	Adjustment bolt
3	Lock nut
4	Connection
A	1 mm (0.039 in)

- Use a wrench to loosen the lock nut and tighten it after making the adjustment with the adjustment bolt.
- Drive, and then check the following.
 - Make sure that heat is not generated in the brake area.
 - Make sure that the left and right brakes are equally effective.

Caution

It may result in an unexpected accident if the left and right brakes are not equally effective.

- If the left and right brakes are not equally effective, make fine adjustments with the adjustment bolt on the brake wire.

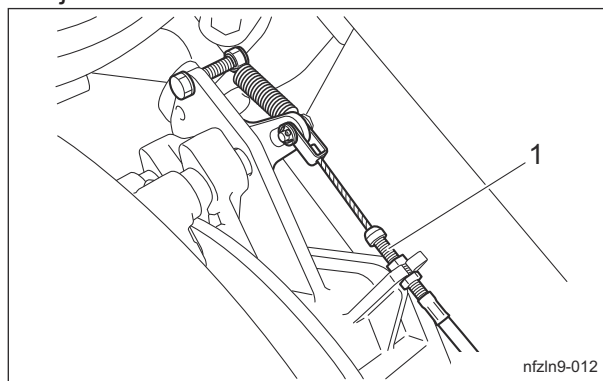

Adjustment of Brake_005

1	Adjustment bolt (on brake disc side)
---	--------------------------------------

Break-In of Brakes

If the brake shoes or brake pads are worn, replace them with new ones. Immediately after replacement, drive to break in the brakes if the effectiveness of the brakes is low. While driving, lightly operate the brakes to break in the contact areas.

Repair

Adjustment of The Neutral Position of The Piston Pump

⚠ Caution

Make sure not to touch rotating tires.

⚠ Caution

When adjusting the neutral position, pay close attention to abrupt start of the machine. Place the jacks beneath the jack-up points, and then lift the machine until all the tires get off the ground.

If the machine moves forward or backward while the traveling pedals are released, they are not set to the neutral position.

Follow the steps below to make adjustments.

1. Stop the engine.
2. Place the jacks beneath the jack-up points, and then lift the machine off the ground.
3. Make sure that no tires come into contact with the jack stand.
4. Open the underseat cover.
"Procedure to Open/Close Underseat Cover" (Page 5-3)
5. Start the engine, and rev it up to the maximum rpm.
6. Set the 2WD/4WD selector switch to the "2WD" position.
7. Adjust the neutral position.
 - [1] If the front tires rotate forward, loosen the lock nuts, and then turn the neutral adjustment rod to shorten it.
 - [2] If the front tires rotate in reverse, loosen the lock nuts, and then turn the neutral adjustment rod to extend it.

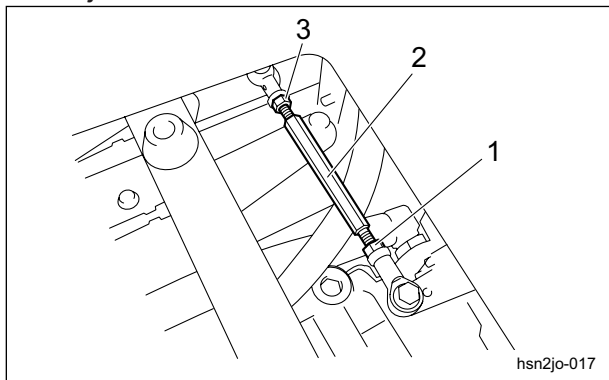

Adjustment of The Neutral Position of The Piston Pump_001

1	Lock nut A (Left-hand thread)
2	Neutral adjustment rod
3	Lock nut B (Right-hand thread)

8. Find the position where the front wheels stop, and then tighten the lock nuts.

Replacement

Replacement of Fuse

Important

When performing maintenance on the electrical system, be sure to remove the negative battery wire.

Important

If a fuse blows, a short may have occurred within the electrical circuit. Check for the cause, such as faulty terminal connections, damaged wiring or terminals, or incorrect wiring.

Important

For fuse replacement, clean the fuse mounting area with use of compressed air before mounting the fuse.

Fuse Box

The fuse box includes spare fuses and tools.

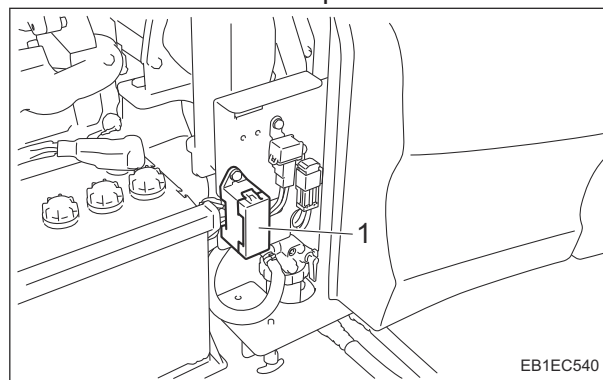

Fuse Box_001

1	Fuse box
---	----------

The machine uses a mini fuse for automobiles.

Replace an old fuse with a new fuse of the specified capacity.

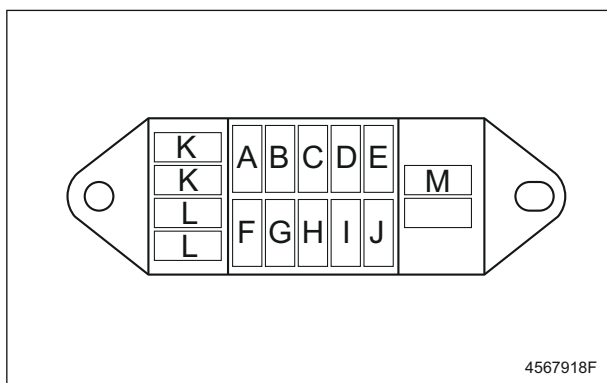

4567918F

Fuse Box_002

A	5 A	Timer
B	5 A	Thermo-start lamp
C	5 A	Tachometer, fuel gauge, water temperature gauge, charge lamp, oil pressure (engine oil pressure) lamp, water temperature buzzer, hydraulic oil buzzer
D	15 A	Relay box 2, 2WD/4WD selection, #4/#5 proximity switches
E	15 A	Relay box 1, differential lock, (assist switch)
F	15 A	LED light
G	5 A	Timer
H	5 A	Alternator
I	5 A	Fuel pump, safety relay, stop solenoid
J	5 A	Relay (starter)
K	5 A	Spare
L	15 A	
M		Fuse removal tool

Fusible Link

Fuse capacities of the fusible links are 30 A and 50 A.

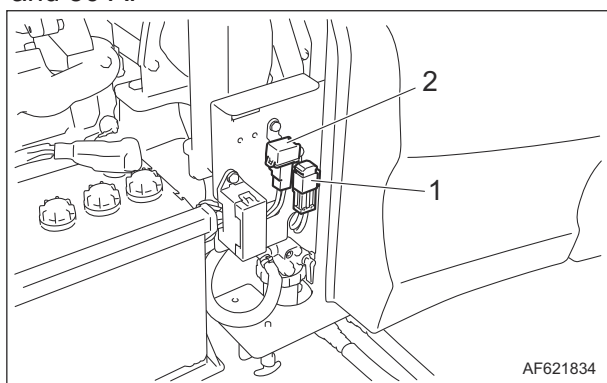

AF621834

Fusible Link_001

1	Fusible link (50 A)
2	Fusible link (30 A)

Towing

Towing The Machine in An Emergency

If the machine does not travel due to engine problems, etc., you can move it by towing it.

⚠ Caution

Before towing, check the brake is applied effectively.

⚠ Caution

Before starting the engine, be sure to close the bypass.

Important

Do not touch the unload valve except when towing the machine.

Important

When towing the machine, obey the following restrictions.

Obey the speed and the time restrictions to prevent damaging the pump or motor.

- Speed: Do not travel at a speed more than 3.0 km/h.
- Time: Do not tow the machine for more than 3 minutes.

When towing the machine for more than 3 minutes, start the engine and circulate the hydraulic oil in the hydraulic circuit.

Therefore, do not tow the machine until restart the engine after completed repairs.

1. Stop the engine.
"Procedure to Stop Engine" (Page 5-12)
2. Apply the parking brake.
3. Chock the wheels.

Repair

- Secure the machine with ropes.
Front left side

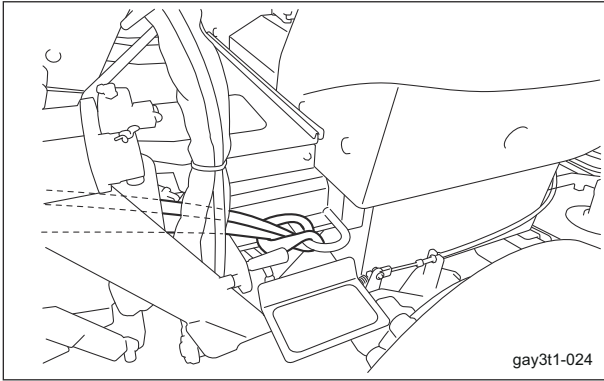

Towing The Machine in An Emergency_001

Front right side

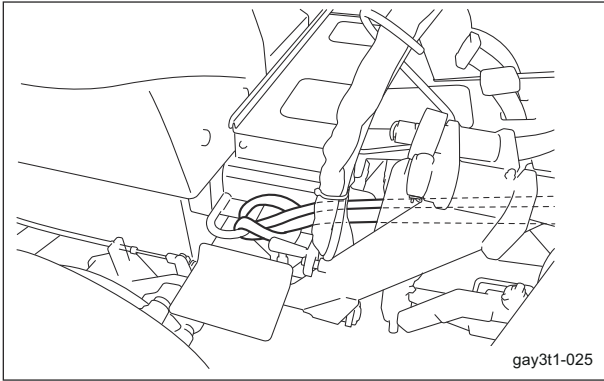

Towing The Machine in An Emergency_002

Rear side

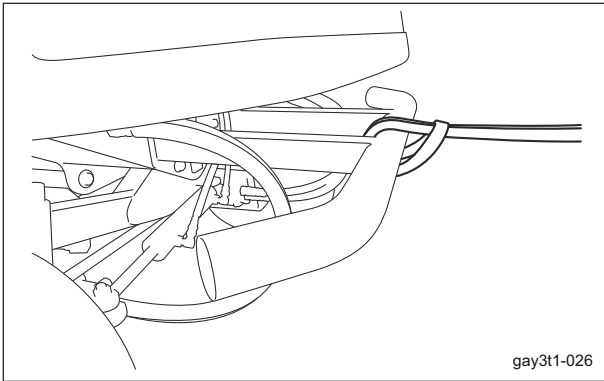

Towing The Machine in An Emergency_003

- Set the 2WD/4WD selector switch to the "2WD" position.
- Open the underseat cover.
"Procedure to Open/Close Underseat Cover"
(Page 5-3)

- Open the bypass.

Turn the needle valve of the unload valve 90 degrees (so that it is vertical) located beside the hydraulic pump to set it to the "Unload" position.

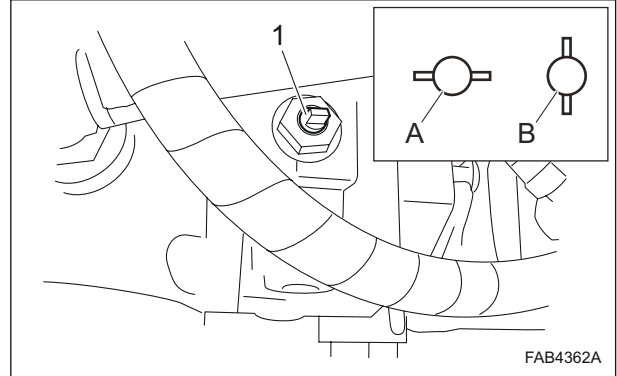

Towing The Machine in An Emergency_004

1	Unload valve
A	Onload
B	Unload

- Close the underseat cover.
- Remove the wheel stopper.
- Release the parking brake.

Warning

While towing, always keep your foot on the brake pedal to make sure you can depress it at any time to stop.

- Tow the machine slowly.
- After towing is completed, close the bypass.
Turn the needle valve of the unload valve 90 degrees (so that it is horizontal) to set it to the "Onload" position.

Appended Table

Tightening Torques	Page 8-2
Standard Tightening Torques	Page 8-2
Principal Tightening Torques	Page 8-5
Daily Check List	Page 8-7
Maintenance Schedule	Page 8-9
List of Adjusted Values	Page 8-12

Appended Table

Tightening Torques

Important

Refer to the Tightening Torque table.
Note that the Baroness product warranty may not apply to defects caused by incorrect or overtorque tightening, etc.

Standard Tightening Torques

Bolts and Nuts



Important

A number of bolts are used in each part of this machine.
Be sure to re-tighten the bolts and nuts, because they may be loosened at the earlier stage of the use.

- As to the bolts and nuts without any special instruction, tighten them in appropriate tightening torque with proper tool.
Too much tightening may cause the looseness or damage of the screw.
- The strength of tightening is determined by types of screws, strength, the friction of thread face or base face and others.
The table below is for the galvanized or parkerized bolts.
In case that the strength of internal thread is weak, it is not applied.
- Do not use rusty or sand attached "screw."
Otherwise, it may cause insufficient tightening even if you apply the specified tightening torque.
The friction of the screw face becomes higher and the tightening torque is canceled out by the friction, therefore sufficient tightening cannot be applied.
- If "screw" is wet by water or oil, do not tighten it with normal tightening torque.
If the screw is wet, the torque coefficient will get smaller and it may result in too much tightening.
Too much tightening may cause looseness by the screw stretched or result in damage.
- Do not use a bolt experienced too much burden.
- Using the impact wrench requires the skill.
Do exercise as much as possible for steady tightening.

Appended Table

Nominal diameter	General bolt		
	Strength classification 4.8		
	 tib3yb-001		
	N-m	kgf-cm	lb-in
M5	3 - 5	30.59 - 50.99	26.55 - 44.26
M6	7 - 9	71.38 - 91.77	61.96 - 79.66
M8	14 - 19	142.76 - 193.74	123.91 - 168.17
M10	29 - 38	295.71 - 387.49	256.68 - 336.34
M12	52 - 67	530.24 - 683.20	460.25 - 593.02
M14	70 - 94	713.79 - 958.52	619.57 - 831.99
M16	88 - 112	897.34 - 1142.06	778.89 - 991.31
M18	116 - 144	1,182.85 - 1,468.37	1,026.72 - 1,274.54
M20	147 - 183	1,498.96 - 1,866.05	1,301.10 - 1,619.73
M22	295	3,008.12	2,611.05
M24	370	3,772.89	3,274.87
M27	550	5,608.35	4,868.05
M30	740	7,545.78	6,549.74

Nominal diameter	Heat-treated bolt					
	Strength classification 8.8			Strength classification 10.9		
	 tib3yb-002			 tib3yb-003		
	N-m	kgf-cm	lb-in	N-m	kgf-cm	lb-in
M5	5 - 7	50.99 - 71.38	44.26 - 61.96	7 - 10	71.38 - 101.97	61.96 - 88.51
M6	8 - 11	81.58 - 112.17	70.81 - 97.36	14 - 18	142.76 - 183.55	123.91 - 159.32
M8	23 - 29	234.53 - 295.71	203.57 - 256.68	28 - 38	285.52 - 387.49	247.83 - 336.34
M10	45 - 57	458.87 - 581.23	398.30 - 504.51	58 - 76	591.43 - 774.97	513.36 - 672.68
M12	67 - 85	683.20 - 866.75	593.02 - 752.34	104 - 134	1,060.49 - 1,366.40	920.50 - 1186.03
M14	106 - 134	1,080.88 - 1,366.40	938.21 - 1,186.03	140 - 188	1,427.58 - 1,917.04	1,239.14 - 1,663.99
M16	152 - 188	1,549.94 - 1,917.04	1,345.35 - 1,663.99	210 - 260	2,141.37 - 2,651.22	1,858.71 - 2,301.26
M18	200 - 240	2,039.40 - 2,447.28	1,770.20 - 2,124.24	280 - 340	2,855.16 - 3,466.98	2,478.28 - 3,009.34
M20	245 - 295	2,498.27 - 3,008.12	2,168.50 - 2,611.05	370 - 450	3,772.89 - 4,588.65	3,274.87 - 3,982.95
M22	-	-	-	530	5,404.41	4,691.03
M24	-	-	-	670	6,831.99	5,930.17
M27	-	-	-	1,000	10,197.00	8,851.00
M30	-	-	-	1,340	13,663.98	11,860.34

Note:

The same values are applied to "fine screw thread."

Appended Table

Hydraulic Hose

The tightening torques for union joints and union adaptors with parallel pipe threads (G, PF) are shown in the table below.

A union joint or adaptor will not become loose or leak as long as it is tightened by the specified torque.

If fluid leaks from the sealed portion, do not attempt to tighten the union joint or adaptor forcibly.

Examine whether any foreign matter or scratches are present on the seat surface.

Tightening a union joint or adaptor forcibly could damage the connection of the joints.

When tightening a union joint or adaptor, use a torque wrench where possible and firmly tighten it by an appropriate torque.

Nominal diameter of the hose size	Nominal diameter of the parallel pipe threads (G, PF)	Tightening torque		
		N-m	kgf-cm	lb-in
6	1/4	25	254.93	221.28
9	3/8	50	509.85	442.55
12	1/2	60	611.82	531.06
15	3/4	120	1,223.64	1,062.12
19	3/4	120	1,223.64	1,062.12
25	1	140	1,427.58	1,239.14
32	1-1/4	170	1,733.49	1,504.67
38	1-1/2	210	2,141.37	1,858.71
50	2	250	2,549.25	2,212.75

Fittings with Parallel Threads (O-Ring Seal Type)

The tightening torques for fittings with parallel threads (O-ring seal method) are shown in the table below.

Tightening the fitting forcibly with a spanner or other such tool to secure it to a set position could damage the fitting, its washers, and other parts.

When tightening an adjustable elbow, use a torque wrench where possible and firmly tighten it by an appropriate torque.

Nominal diameter of thread	Tightening torque		
	N-m	kgf-cm	lb-in.
1/4	34.32 - 49.03	349.96 – 499.96	303.77 – 433.96
3/8	68.65 - 78.45	700.02 – 799.95	607.62 – 694.36
1/2	98.07 - 117.68	1,000.02 – 1,199.98	868.02 – 1,041.59
3/4	147.10 - 176.52	1,499.98 – 1,799.97	1,301.98 – 1,562.38
1	245.17 - 274.59	2,500.00 – 2,799.99	2,170.00 – 2,430.40
1-1/4	294.20	2,999.96	2,603.96
1-1/2	294.20	2,999.96	2,603.96
2	392.27	3,999.98	3,471.98

Appended Table

Principal Tightening Torques

Tightening Torque by Model

GM2800C

Tighten the following bolts and nuts at the torque specified in the table.

For thread locking adhesive, apply a middle strength thread locker (ThreeBond 1322 or equivalent anaerobic sealant).

Location	Code	Part name	Tightening torque			Thread locking adhesive	
			N-m	kgf-cm	lb-in		
Front wheel	Motor housing	K0014160402	BOLT, HT P1.5 M16-40	152 - 188	1,549.94 - 1,917.04	1,345.35 - 1,663.99	-
	Motor	K0013140502	BOLT, HT M14-50	100	1,019.70	885.10	-
	Wheel mounting base	1 • 1/4-18UNF	Slotted nut (Hydraulic motor)	400 - 430	4,078.80 - 4,384.71	3,540.40 - 3,805.93	-
	Brake disc	K001A080401	BOLT, 13T W/HEX HOLE M8-40	28 - 38	285.52 - 387.49	247.83 - 336.34	-
	Wheel	K0014120652	BOLT, HT P1.5 M12-65	110	1,121.67	973.61	-
Rear wheel	Wheel mounting base	K0138240002	NUT, HIGH SLOTTED P1.5 M24	180 - 200	1,835.46 - 2,039.40	1,593.18 - 1,770.20	-
	Wheel	K0014120652	BOLT, HT P1.5 M12-65	110	1,121.67	973.61	-
Front axle	K0015200702	BOLT, HT P1.5 M20-70	370 - 450	3,772.89 - 4,588.65	3,274.87 - 3,982.95	-	
Brake Assy	K1720000270	NUT, M12 (accessories)	50 - 70	509.85 - 713.79	442.55 - 619.57	○	
	K1720000260	NUT, M12 (accessories)	50 - 70	509.85 - 713.79	442.55 - 619.57	○	
Engine	K0012120352	BOLT, HT P1.25 M12-35	67 - 85	683.20 - 866.75	593.02 - 752.34	-	
	K0012120552	BOLT, HT P1.25 M12-55	67 - 85	683.20 - 866.75	593.02 - 752.34	-	
	K0011100502	BOLT, HT P1.25 M10-50	58 - 76	591.43 - 774.97	513.36 - 672.68	-	
	K0013121102	BOLT, HT M12-110	67 - 85	683.20 - 866.75	593.02 - 752.34	-	
	K3680000030	Screw, M3.5 (accessories)	0.78 - 1.18	7.95 - 12.03	6.90 - 10.44	-	
Electric components for engine	-	Starter B terminal (M8)	5.9 - 11.7	60.16 - 119.30	52.22 - 103.56	-	
	-	Alternator B terminal (M6)	5.9 - 9.8	60.16 - 99.93	52.22 - 86.74	-	
	-	Glow plug connection terminal nut (M4)	1.0 - 1.8	10.20 - 18.35	8.85 - 15.93	-	
Flywheel adapter	K0010140402	BOLT, HT M14-40	140 - 188	1,427.58 - 1,917.04	1,239.14 - 1,663.99	-	
	K0010100352	BOLT, HT M10-35	45 - 76	458.87 - 774.97	398.30 - 672.68	-	

Appended Table

Location	Code	Part name	Tightening torque			Thread locking adhesive
			N-m	kgf-cm	lb-in	
Joint	K001A100401	BOLT, 13T W/HEX HOLE M10-40	80	815.76	708.08	-
	K0013100352	BOLT, HT M10-35	45 - 76	458.87 - 774.97	398.30 - 672.68	-
Kingpin stopper	K0010120502	BOLT, HT M12-50 (lock nut)	52 - 67	530.24 - 683.20	460.25 - 593.02	-
Tie rod	K1610000020	Tie rod end slotted nut (RH)	45	458.87	398.30	-
	K1611000020	Tie rod end slotted nut (LH)	45	458.87	398.30	-
Piston pump	K0010120502	BOLT, HT M12-50	67 - 134	683.20 - 1,366.40	593.02 - 1,186.03	-
Tandem gear pump	K0069000251	BOLT, 3/8-16 UNC 31.8	29 - 38	295.71 - 387.49	256.68 - 336.34	-
Pedal stopper	K0013101202	BOLT, HT M10-120 (lock nut)	29 - 38	295.71 - 387.49	256.68 - 336.34	-
Diff-lock valve	K001A100151	BOLT, 13T W/HEX HOLE M10-15	29 - 38	295.71 - 387.49	256.68 - 336.34	-
Knife and Knife guide	K0010120302	BOLT, HT P1.75 M12-30	104 - 134	1,060.49 - 1,366.40	920.50 - 1,186.03	-
Shoulder bolt	GM2800-0207Z2	BOLT, STEPPED	67 - 134	683.20 - 1,366.40	593.02 - 1,186.03	-
Bumper	K0010120302	BOLT, HT P1.75 M12-30	67 - 134	683.20 - 1,366.40	593.02 - 1,186.03	-
Cover mounting bracket	K0000080202	BOLT, M8-20	9 - 14	91.77 - 142.76	79.66 - 123.91	-
ROPS	K0013121102	BOLT, HT M12-110	104 - 134	1,060.49 - 1,366.40	920.50 - 1,186.03	-
Battery terminal	K3612000070	Terminal, battery (+) 4013-D-8-1	9	91.77	79.66	-
	K3612000080	Terminal, battery (-) 4013-D-8-2	9	91.77	79.66	-

Appended Table

Daily Check List

GM2800C

● . . . Inspect, adjust, supply, clean (first time)

○ . . . Inspect, adjust, supply, clean

▲ . . . Replace (first time)

△ . . . Replace

Maintenance Item		Before Work	After Work	Remarks
Engine	*1	Check engine oil	○	
	*1	Check fuel	○	
		Check fuel filter	○	
	*1	Check coolant	○	
	*1	Check air cleaner	○	
		Check radiator cover	○	
		Check radiator	○	
		Check engine area	○	
		Clean radiator cover		○
	*1	Clean radiator		○
	Clean engine area		○	
Main vehicle		Check hydraulic oil	○	
		Check tire	○	
	*2	Check battery	○	
		Check oil cooler	○	
		Check cover	○	
		Check brake pedal	○	
		Check parking brake lever	○	
		Check traveling pedal	○	
		Check wire	○	
		Check liquid leakage	○	
		Check ball proof net	○	
		Clean machine exterior	○	
		Check bolts and nuts	○	
		Check tachometer and hour meter	○	
		Check water temperature gauge	○	
		Check fuel gauge	○	
		Check pilot lamp	○	
		Check safety device	○	
		Check steering wheel	○	
		Check lighting	○	
	Clean oil cooler		○	
	Clean machine exterior		○	

Appended Table

Maintenance Item		Before Work	After Work	Remarks
Mower deck	Check rotary knife	<input type="radio"/>		
	Check roller	<input type="radio"/>		
	Check cover	<input type="radio"/>		
	Check bolts and nuts	<input type="radio"/>		
	Check cutting height	<input type="radio"/>		
	Clean mower deck		<input type="radio"/>	

- *1: Refer to the Engine's Owner's Manual.
- *2: Refer to the Battery's Owner's Manual.

Appended Table

Maintenance Schedule

GM2800C

● . . . Inspect, adjust, supply, clean (first time)

○ . . . Inspect, adjust, supply, clean

▲ . . . Replace (first time)

△ . . . Replace

Maintenance Item		Before Work	After Work	Every Week	Every 50 hrs.	Every 100 hrs.	Every 200 hrs.	Every 400 hrs.	Every 500 hrs.	Every 800 hrs.	Every 1500 hrs.	Every 3000 hrs.	Every month	every 3 months	every 6 months	Every year	Every 2 years	Every 4 years	When Required	Remarks		
Engine	*3		○	○																Open valve every week or daily in dusty conditions		
	*2.*3				○																	
	*3					○																
	*2.*3					○															Air cleaner should be cleaned more often in dusty conditions than in normal conditions	
	*3					○																
	*2.*3						○															
	*3							○								○					Every 200 hours or every 6 month whichever comes earlier	
	*3								○													
	*1.*3									○												
*1.*3										○												

Appended Table

Maintenance Item		Before Work	After Work	Every Week	Every 50 hrs.	Every 100 hrs.	Every 200 hrs.	Every 400 hrs.	Every 500 hrs.	Every 800 hrs.	Every 1500 hrs.	Every 3000 hrs.	Every month	every 3 months	every 6 months	Every year	Every 2 years	Every 4 years	When Required	Remarks	
Engine	*1.*3	Check valve clearance								○											
	*1.*2 .*3	Check of fuel injection nozzle injection pressure									○										
	*1.*2 .*3	Check turbocharger										○									
	*1.*2 .*3	Check of injection pump										○									
	*3	Replace engine oil				▲		△									△				Initial 50 hours, thereafter every 200 hours or every year whichever comes earlier
	*3	Replace engine oil filter cartridge				▲		△									△				Initial 50 hours, thereafter every 200 hours or every year whichever comes earlier
	*2.*3	Replace fuel filter cartridge							△												
	*3	Replace fan belt								△								△			Every 500 hours or 2 years whichever comes earlier
	*2.*3	Replace air cleaner outer element															△				Every 6 cleanings or every year whichever comes earlier
*3	Replace radiator coolant (L.L.C.)																△				

Appended Table

Maintenance Item		Before Work	After Work	Every Week	Every 50 hrs.	Every 100 hrs.	Every 200 hrs.	Every 400 hrs.	Every 500 hrs.	Every 800 hrs.	Every 1500 hrs.	Every 3000 hrs.	Every month	every 3 months	every 6 months	Every year	Every 2 years	Every 4 years	When Required	Remarks	
Engine	*1.*3	Replace radiator hoses and clamp bands															△				
	*1.*2 .*3	Replace fuel hoses and clamp bands															△				
	*1.*2 .*3	Replace intake air line (air cleaner hose) and clamp bands															△				
Main vehicle		Check hydraulic hose (Moving part)	○																		
		Grease and Lubricate				○										○				Maintenance schedules differ according to greasing points	
		Grease rear mower deck swing out pins				○															
		Check electrical wiring				●	○														
		Check wheel mounting bolts				●	○														
		Check hydraulic hose (Fixed part) condition					○										○				Every 100 hours or every month whichever comes earlier
		Replace hydraulic oil					▲			△											
		Replace hydraulic oil suction filter					▲			△											
		Replace hydraulic oil line filter					▲			△											
		Replace air breather element					▲			△											
		Replace resin bushing																△			
		*4	Replace battery															△			
		*1	Replace hydraulic hoses (Moving part)															△			

Appended Table

Maintenance Item		Before Work	After Work	Every Week	Every 50 hrs.	Every 100 hrs.	Every 200 hrs.	Every 400 hrs.	Every 500 hrs.	Every 800 hrs.	Every 1500 hrs.	Every 3000 hrs.	Every month	every 3 months	every 6 months	Every year	Every 2 years	Every 4 years	When Required	Remarks
Main vehicle	*1.*5	Replace hydraulic hoses (Moving part) relating to steering																△		
	*1	Replace hydraulic hoses (Fixed part)																	△	
		Replace brake cables																		△
		Replace brake pads																		△
Mower deck		Grease			○															
		Adjust cutting height																		○
		Sharpen and balance rotary knife																		○ Sharpen/ Balance/ Replace rotary knife if needed.

- *1: Consult your local Baroness Dealer or local KUBOTA Dealer for this service.
- The items above (*2 marked) are registered as emission related critical parts by KUBOTA in the U.S. EPA nonroad emission regulation.
As the engine owner, you are responsible for the performance of the required maintenance on the engine according to the above instruction.
Please see the Engine's Warranty Statement in detail.
- *3: Refer to the Engine's Owner's Manual.
- *4: Refer to the Battery's Owner's Manual.
- The values for consumables are not guaranteed.
- *5: Be sure to replace hydraulic hoses for steering cylinder and hydraulic hoses for hydraulic motor of wheel relating to steering every two years.

List of Adjusted Values

Fan belt	10 - 12 mm (0.39 - 0.47 in)	Slack when applying 98 N (10 kgf) force to the belt at the middle point
	Adjustment: 237 - 403 N (24.17 - 41.09 kgf) Replacement: 460 - 680 N (46.91 - 69.34 kgf)	Measurement of belt tension by using a sonic type tension meter
Brake	0.2 mm (0.0079 in)	Clearance between the brake disc and the pad
	1 mm (0.039 in)	Play at the connection of the inner wire

Daily Check Records Page 9-2

Maintenance RecordsPage 9-5

Records

Daily Check Records

GM2800C

Use this table freely for your records of the daily check.

Model		Serial Number	
-------	--	---------------	--

Items										
Engine	Check engine oil									
	Check fuel									
	Check fuel filter									
	Check coolant									
	Check air cleaner									
	Check radiator cover									
	Check radiator									
	Check engine area									
	Clean radiator cover									
	Clean radiator									
	Clean engine area									

Items										
Main vehicle	Check hydraulic oil									
	Check tire									
	Check battery									
	Check oil cooler									
	Check cover									
	Check brake pedal									
	Check parking brake lever									
	Check traveling pedal									
	Check wire									
	Check liquid leakage									
	Check ball proof net									
	Clean machine exterior									
	Check bolts and nuts									
	Check tachometer and hour meter									

Records

Records

Items											
Main vehicle	Check water temperature gauge										
	Check fuel gauge										
	Check pilot lamp										
	Check safety device										
	Check steering wheel										
	Check lighting										
	Clean oil cooler										
	Clean machine exterior										
Mower deck	Check rotary knife										
	Check roller										
	Check cover										
	Check bolts and nuts										
	Check cutting height										
	Clean mower deck										

Maintenance Records

GM2800C
 Use this table freely for your records of the maintenance.

Model		Serial Number	
-------	--	---------------	--

	Items									
Engine	Open air cleaner evacuator valve to remove dust									
	Check fuel hoses and clamp bands									
	Draining of water separator									
	Clean air cleaner outer element									
	Check of fan belt tightness									
	Check intake air line (air cleaner hose)									
	Check radiator hoses and clamp bands									
	Clean of water separator									
	Clean fuel tank interior									
	Clean water jacket (radiator interior)									
	Check valve clearance									
	Check of fuel injection nozzle injection pressure									

Records

Records

Items											
Engine	Check turbocharger										
	Check of injection pump										
	Replace engine oil										
	Replace engine oil filter cartridge										
	Replace fuel filter cartridge										
	Replace fan belt										
	Replace air cleaner outer element										
	Replace radiator coolant (L.L.C.)										
	Replace radiator hoses and clamp bands										
	Replace fuel hoses and clamp bands										
Replace intake air line (air cleaner hose) and clamp bands											
Main vehicle	Check hydraulic hose (Moving part)										
	Grease and Lubricate										
	Grease rear mower deck swing out pins										

Items											
Main vehicle	Check electrical wiring										
	Check wheel mounting bolts										
	Check hydraulic hose (Fixed part) condition										
	Replace hydraulic oil										
	Replace hydraulic oil suction filter										
	Replace hydraulic oil line filter										
	Replace air breather element										
	Replace resin bushing										
	Replace battery										
	Replace hydraulic hoses (Moving part)										
	Replace hydraulic hoses (Moving part) relating to steering										
	Replace hydraulic hoses (Fixed part)										
	Replace brake cables										
	Replace brake pads										

Records

Records

Items											
Mower deck	Grease										
	Adjust cutting height										
	Sharpen and balance rotary knife										

BARONESS[®]
Quality on Demand

 **KYOEISHA CO., LTD.**
Head Office 1-26, Miyuki-cho, Toyokawa-city, Tel :+81-533-84-1390
Aichi-pref, 442-8530 JAPAN Fax:+81-533-84-1220