

Trencher

AP-TR48 & AP-TR60

70657

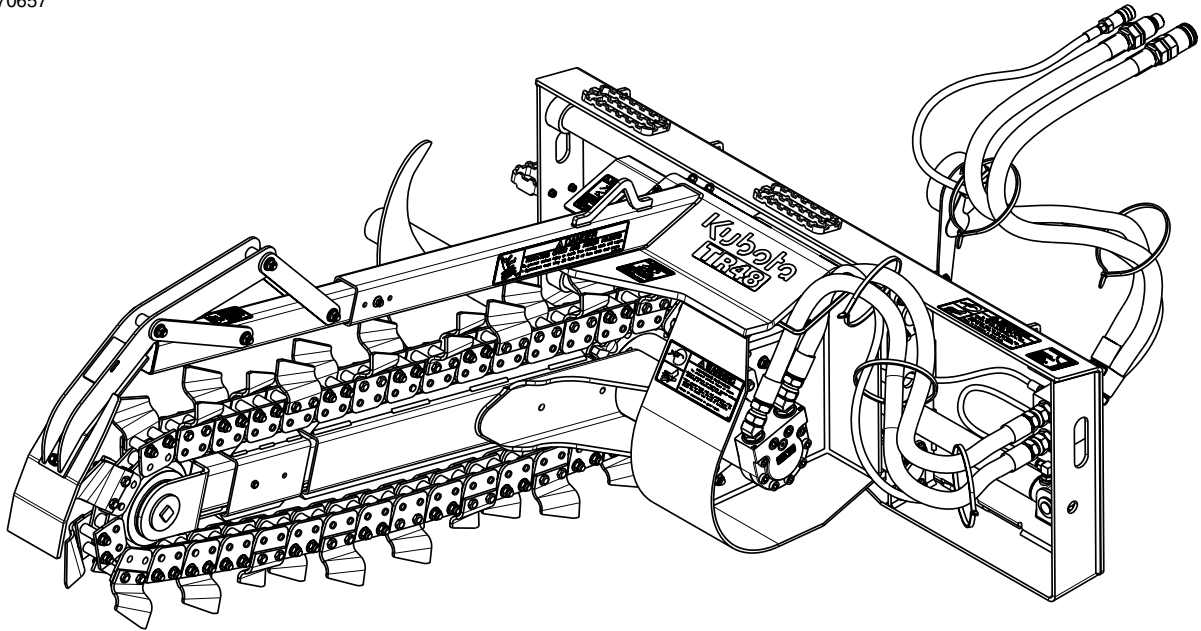

350-234MK Operator's Manual



Read the Operator's Manual entirely. When you see this symbol, the subsequent instructions and warnings are serious - follow without exception. Your life and the lives of others depend on it!

Cover photo may show optional equipment not supplied with standard unit.

For an Operator's Manual and Decal Kit in French Language, please see your Kubota dealer.

Kubota®

Machine Identification

Record your machine details in the log below. If you replace this manual, be sure to transfer this information to the new manual.

If you, or the dealer, have added Options not originally ordered with the machine, or removed Options that were originally ordered, the weights and measurements are no longer accurate for your machine. Update the record by adding the machine weight and measurements provided in the Specifications & Capacities Section of this manual with the Option(s) weight and measurements.

| | |
|------------------------|-------------------|
| Model Number | |
| Serial Number | |
| Machine Height | |
| Machine Length | |
| Machine Width | |
| Machine Weight | |
| Delivery Date | |
| First Operation | |
| Accessories | <hr/> <hr/> <hr/> |

Dealer Contact Information

Name: _____

Street: _____

City/State: _____

Telephone: _____

Email: _____

California Proposition 65

 **WARNING:** Handling passenger or off-highway motor vehicle parts can expose you to chemicals such as phthalates and lead, which can cause cancer and reproductive harm. To minimize exposure, service the vehicle in a well-ventilated area, wear gloves, and wash your hands. For more information see www.P65Warnings.ca.gov/motor-vehicle-parts.

| | | | |
|--|-----------|--|-----------|
| Important Safety Information | 1 | Section 4: Options | 26 |
| Safety at All Times | 1 | Crumber Shoe Option | 26 |
| Look for the Safety Alert Symbol | 1 | Trencher Chain Selection Options | 26 |
| Be Aware of Signal Words | 1 | Standard Cups, 2 Pitch Spacing | 28 |
| Be Aware of Special Notices | 1 | Standard Cups, 4 Pitch Spacing | 30 |
| Safety Labels | 6 | Alligator and Cup Teeth | 32 |
| Introduction | 10 | Scorpion and Cup Teeth | 34 |
| Application | 10 | Section 5: Maintenance & Lubrication | 36 |
| Using This Manual | 10 | Maintenance | 36 |
| Terminology | 10 | General Inspection | 36 |
| Owner Assistance | 10 | Chain Service in Harsh Conditions | 36 |
| Serial Number | 10 | Auger Removal | 37 |
| Further Assistance | 10 | Auger Installation | 37 |
| Section 1: Assembly & Set-up | 11 | Side Shift Bars | 37 |
| Skid Steer/Track Loader Requirements | 11 | Crumber Shoe Maintenance | 38 |
| Torque Requirements | 11 | Check Chain Tension | 38 |
| Before You Start | 11 | Check Chain and Sprocket Wear | 38 |
| Lift / Transport Anchor Points | 11 | Chain Removal and Replacement | 38 |
| Dealer Preparation and Set-up | 12 | Prep for Chain Removal | 38 |
| Check Chain Overall Width | 12 | Remove & Install Continuous Chain Loop | 39 |
| Check Auger Offset | 12 | Chain Removal: | 39 |
| Check Crumber Shoe Size | 12 | Chain Installation | 39 |
| Check Chain Tension | 13 | Remove & Install Single Chain Strand | 40 |
| Attach Depth Indicator | 13 | Chain Removal | 40 |
| Check Crumber Arm Clearance | 13 | Chain Installation | 40 |
| Connect Trencher | 14 | Sprocket Replacement | 41 |
| Connect Hydraulics | 15 | General Tooth Maintenance | 42 |
| Equipment Clearances | 16 | Cup Teeth | 43 |
| Skid Steer/Track Loader Shutdown Procedure | 16 | Alligator Teeth | 43 |
| Section 2: Adjustments | 17 | Scorpion Teeth | 43 |
| Side Shift Trencher | 17 | Remove & Install Front Roller | 44 |
| Manual Side Shift Option | 17 | Remove Front Roller | 44 |
| Hydraulic Side Shift Option | 18 | Install Front Roller | 44 |
| Adjust Auger Position | 18 | Replace Bearings in Front Roller | 44 |
| Adjust Chain Tension | 19 | Remove Old Bearings From Front Roller | 44 |
| Adjust Crumber Arm | 20 | Install New Bearings in Front Roller | 44 |
| Section 3: Operating Instructions | 21 | Long-Term Storage | 45 |
| Operating Checklist | 21 | Lubrication Points | 45 |
| General Safety Information | 21 | Side Shift Rods | 45 |
| Equipment Inspection | 22 | Section 6: Specifications & Capacities | 46 |
| Transporting | 22 | Section 7: Features & Benefits | 48 |
| Operating Guidelines | 23 | Section 8: Troubleshooting | 49 |
| General Operating Instructions | 24 | Section 9: Torque Values Chart | 51 |
| Disconnect Trencher | 25 | Section 10: Warranty & Legal Disclaimer | 52 |

© Copyright 2025 All rights Reserved

Kubota provides this publication "as is" without warranty of any kind, either expressed or implied. While every precaution has been taken in the preparation of this manual, Kubota assumes no responsibility for errors or omissions. Neither is any liability assumed for damages resulting from the use of the information contained herein. Kubota reserves the right to revise and improve its products as it sees fit. This publication describes the state of this product at the time of its publication, and may not reflect the product in the future.

Kubota is a registered trademark.

All other brands and product names are trademarks or registered trademarks of their respective holders.

Printed in the United States of America.

See previous page for Table of Contents.



Parts Manual QR Locator

The QR (Quick Reference) code on the left will take you to the Parts Manual for this equipment. Download the appropriate app on your smart phone. Scan the QR code and take a picture.



Dealer QR Locator

The QR code on the left will link you to available dealers for Kubota products. Refer to Parts Manual QR Locator on this page for detailed instructions.

Listed below are common practices that may or may not be applicable to the products described in this manual.

Safety at All Times

Careful operation is your best assurance against an accident.

All operators, no matter how much experience they may have, should carefully read this manual and other related manuals before operating the power machine and this attachment.

- ▲ Thoroughly read and understand the "Safety Label" section. Read all instructions noted on them.
- ▲ Do not operate the equipment while under the influence of drugs or alcohol, as they impair your ability to safely and properly operate the equipment.
- ▲ Operator should be familiar with all functions of the skid steer / track loader and attachment and be able to handle emergencies quickly.
- ▲ Make sure all guards and shields appropriate for the operation are in place and secured before operating the attachment.
- ▲ Keep all bystanders away from equipment and work area.
- ▲ Start skid steer or track loader from the driver's seat with steering levers and hydraulic controls in neutral.
- ▲ Operate skid steer or track loader and controls from the driver's seat only.
- ▲ Never dismount from a moving skid steer / track loader or leave the machine unattended with the engine running.
- ▲ Do not allow anyone to stand between the attachment and skid steer or track loader while connecting to the attachment.
- ▲ Keep hands, feet, and clothing away from power-driven parts.
- ▲ While transporting and operating equipment, watch out for objects overhead and along the sides such as fences, trees, buildings, wires, etc.
- ▲ Store attachment in an area where children normally do not play. When needed, secure attachment against falling with support blocks.



Look for the Safety Alert Symbol

The SAFETY ALERT SYMBOL indicates there is a potential hazard to personal safety and extra precaution must be taken. When you see this symbol, be alert and carefully read the message that follows it. Hazard control, and accident prevention are dependent upon the awareness, concern, prudence, and proper training of personnel involved in the operation, transport, maintenance, and storage of equipment.

Be Aware of Signal Words

A signal word designates a degree or level of hazard seriousness. They are:

- ▲ **DANGER:** Indicates a hazardous situation that, if not avoided, will result in death or serious injury.
- ▲ **WARNING:** Indicates a hazardous situation that, if not avoided, could result in death or serious injury.
- ▲ **CAUTION:** Indicates a hazardous situation that, if not avoided, may result in minor or moderate injury.

Be Aware of Special Notices

Special notices are intended to point out important and helpful information that should be followed. They are usually placed inside a box. They are:

- ▲ **IMPORTANT:** Indicates that equipment or property damage could result if instructions are not followed.
- ▲ **NOTE:** Indicates supplementary explanations that will be helpful when using the equipment.

Safety Precautions for Children

Tragedy can occur if the operator is not alert to the presence of children. Children generally are attracted to attachments and their work.

- ▲ Never assume children will remain where you last saw them.
- ▲ Keep children out of the work area and under the watchful eye of a responsible adult.
- ▲ Be alert and shut the attachment and skid steer/track loader down if children enter the work area.
- ▲ Never carry children on the power machine or attachment. There is not a safe place for them to ride. They may fall off and be run over or interfere with the control of the power machine.
- ▲ Never allow children to operate the power machine, even under adult supervision.
- ▲ Never allow children to play on the power machine or attachment.
- ▲ Use extra caution when backing up. Before the power machine starts to move, look down and behind to make sure the area is clear.

Listed below are common practices that may or may not be applicable to the products described in this manual.

Dig Safe - Avoid Underground Utilities

- ▲ USA: Call 811
CAN:
<http://www.clickbeforeyoudig.com>
- ▲ Always contact your local utility companies (electrical, telephone, gas, water, sewer, and others) before digging so that they may mark the location of any underground services in the area.
- ▲ Be sure to ask how close you can work to the marks they positioned.



Towing Safely

- ▲ Comply with federal, state, and local laws.
- ▲ Use towing vehicle and trailer of adequate size and capacity. Secure equipment towed on a trailer with chocks, tie downs, and chains.
- ▲ **IMPORTANT:** Do not tow a load that is more than double the weight of the vehicle towing the load.
- ▲ Sudden braking can cause a towed trailer to swerve unexpectedly. Reduce speed if trailer is not equipped with brakes.

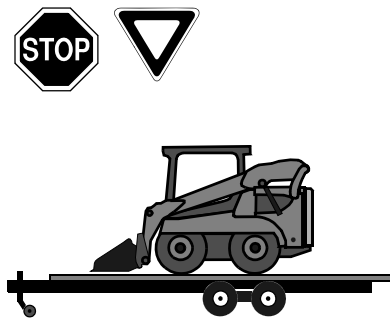

Transport Safely

- ▲ Comply with federal, state, and local laws.
- ▲ Avoid contact with any overhead utility lines or electrically charged conductors.
- ▲ Always drive with attachment on the end of the loader arms low to the ground.
- ▲ Follow recommendations in the power machine Operator's Manual when driving uphill or downhill and when parking on an incline.
- ▲ Never travel at a speed which does not allow adequate control of the load, steering, and stopping. Some rough terrains require a slower speed.

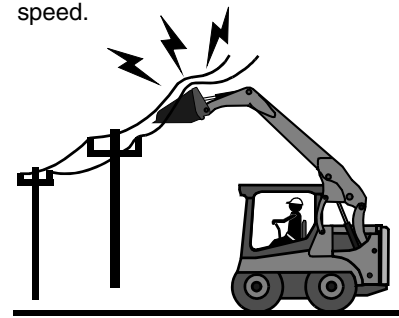

Tire Safety

- ▲ Tire changing can be dangerous and must be performed by trained personnel using the correct tools and equipment.
- ▲ Always properly match the wheel size to the properly sized tire.
- ▲ Always maintain correct tire pressure. Do not inflate tires above recommended pressures shown in the Operator's Manual.
- ▲ When inflating tires, use a clip-on chuck and extension hose long enough to allow you to stand to one side and NOT in front of or over the tire assembly. Use a safety cage if available.
- ▲ Securely support the attachment when changing a wheel.
- ▲ When removing and installing wheels, use wheel handling equipment adequate for the weight involved.
- ▲ Make sure wheel bolts have been tightened to the specified torque.



Practice Safe Maintenance

- ▲ Understand procedure before doing work. Refer to the Operator's Manual for additional information.
- ▲ Work on a level surface in a clean, dry area that is well-lit.
- ▲ Lower attachment to the ground and follow all shutdown procedures before leaving the operator's seat to perform maintenance.
- ▲ Do not work under any hydraulically supported equipment. It can settle, suddenly leak down, or be lowered accidentally. If it is necessary to work under the equipment, securely support it with stands or suitable blocking beforehand.
- ▲ Use properly grounded electrical outlets and tools.
- ▲ Use correct tools and equipment for the job that are in good condition.
- ▲ Allow equipment to cool before working on it.

- ▲ Disconnect battery ground cable (-) before servicing or adjusting electrical systems or before welding on equipment.
- ▲ Inspect all parts. Make certain that parts are in good condition & installed properly.
- ▲ Replace parts on this attachment with genuine Kubota parts only. Do not alter this attachment in a way which will adversely affect its performance.
- ▲ Do not grease or oil attachment while it is in operation.
- ▲ Remove buildup of grease, oil, or debris.
- ▲ Always make sure any material and waste products from the repair and maintenance of the attachment are properly collected and disposed of.
- ▲ Remove all tools and unused parts from the equipment before operation.



These are common practices that may or may not be applicable to the products described in this manual.

Prepare for Emergencies

- ▲ Be prepared if a fire starts.
- ▲ Keep a first aid kit and fire extinguisher handy.
- ▲ Keep emergency numbers for doctor, ambulance, hospital, and fire department near phone.

Wear Personal Protective Equipment (PPE)

- ▲ Wear protective clothing and equipment appropriate for the job such as safety shoes, safety glasses, hard hat, dust mask, and ear plugs.
- ▲ Clothing should fit snug without fringes and pull strings to avoid entanglement with moving parts.
- ▲ Prolonged exposure to loud noise can cause hearing impairment or hearing loss. Wear suitable hearing protection such as earmuffs or earplugs.
- ▲ Operating a machine safely requires the operator's full attention. Avoid wearing headphones while operating equipment.

Avoid High Pressure Fluids

- ▲ Escaping fluid under pressure will penetrate the skin or eyes causing serious injury.
- ▲ Relieve all residual pressure before disconnecting hydraulic lines or performing work on the hydraulic system.
- ▲ Make sure all hydraulic fluid connections are properly tightened/torqued and all hydraulic hoses and lines are in good condition before applying pressure to the system.
- ▲ Use a piece of cardboard or wood, NOT BODY PARTS, to check for suspected leaks.
- ▲ Wear protective gloves and safety glasses or goggles when working with hydraulic systems.
- ▲ **DO NOT DELAY.** If an accident occurs, seek immediate emergency medical care or gangrene may result.

Use Safety Lights and Devices

- ▲ A slow moving power machine can create a hazard when driven on public roads. They are difficult to see, especially at night.
- ▲ Flashing warning lights and turn signals are recommended whenever driving on public roads.
- ▲ For tractors and other agriculture equipment, a Slow Moving Vehicle (SMV) sign is required when traveling on public roads.

Use Seat Belt and ROPS

- ▲ Land Pride recommends the use of a CAB or roll-over-protective-structures (ROPS) and seat belt in almost all power machines. Combination of a CAB or ROPS and seat belt will reduce the risk of serious injury or death if the power machine should be upset.
- ▲ If ROPS is in the locked-up position, fasten seat belt snugly and securely to help protect the operator against serious injury or death from falling and/or machine overturn.

Keep Riders Off Machinery

- ▲ Never carry riders on the power machine or attachment.
- ▲ Riders obstruct operator's view and interfere with the control of the power machine.
- ▲ Riders can be struck by objects or thrown from the equipment.
- ▲ Never use the power machine or attachment to lift or transport riders.

Listed below are common practices that may or may not be applicable to the products described in this manual.

Avoid Crystalline Silica (Quartz) Dust

Because crystalline silica is a basic component of sand and granite, many activities at construction sites produce dust containing crystalline silica. Trenching, sawing, and boring of material containing crystalline silica can produce dust containing crystalline silica particles. This dust can cause serious injury to the lungs (silicosis).

There are guidelines which should be followed if crystalline silica (quartz) is present in the dust.



- ▲ Be aware of and follow OSHA (or other local, State, or Federal) guidelines for exposure to airborne crystalline silica.
- ▲ Know the work operations where exposure to crystalline silica may occur.
- ▲ Participate in air monitoring or training programs offered by the employer.
- ▲ Be aware of and use optional equipment controls such as water sprays, local exhaust ventilation, and enclosed cabs with positive pressure air conditioning if the machine has such equipment. Otherwise respirators shall be worn.
- ▲ Where respirators are required, wear a respirator approved for protection against crystalline silica containing dust. Do not alter respirator in any way. Workers who use tight-fitting respirators can not have beards/mustaches which interfere with the respirator seal to the face.
- ▲ If possible, change into disposable or washable work clothes at the work site; shower and change into clean clothing before leaving the work site.
- ▲ Do not eat, drink, use tobacco products, or apply cosmetics in areas where there is dust containing crystalline silica.
- ▲ Store food, drink, and personal belongings away from the work area.
- ▲ Wash hands and face before eating, drinking, smoking, or applying cosmetics after leaving the exposure area.

Handle Chemicals Properly

- ▲ Protective clothing should be worn.
- ▲ Handle all chemicals with care.
- ▲ Follow instructions on container label.
- ▲ Agricultural chemicals can be dangerous. Improper use can seriously injure persons, animals, plants, soil, and property.
- ▲ Inhaling smoke from any type of chemical fire can be a serious health hazard.
- ▲ Store or dispose of unused chemicals as specified by the chemical manufacturer.



Skid Steer / Track Loader Shutdown And Storage

- ▲ Reduce engine speed and shut-off all power to the attachment.
- ▲ Park on solid, level ground and lower attachment until it is flat on the ground or on non-concrete support blocks.
- ▲ Turn-off engine using the power-off switch or turn ignition key to stop. Do not remove key at this time.
- ▲ Relieve all hydraulic pressures.
 - If using a power-off switch, follow your machine Operator's Manual for instructions on how to release hydraulic pressure in the lines.
 - If using an ignition key, turn key to "RUN" and move joysticks to release hydraulic pressure in the lines. Finish by turning ignition key to off and removing it to prevent unauthorized starting.
- ▲ If included, raise seat bar and move controls until both lock.
- ▲ Wait for all components to stop before leaving operator's seat.
- ▲ Use steps, grab-handles and anti-slip surfaces when stepping on and off the skid steer or track loader.

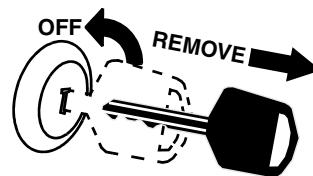

This page left blank intentionally.

Safety Labels

Your trencher comes equipped with all safety labels in place. They are designed to help you safely operate your attachment. Read and follow their directions.

1. Keep all safety labels clean and legible.
2. Refer to this section for proper label placement. Replace all damaged or missing labels. Order new labels from your nearest Kubota dealer. To find your nearest dealer, visit our dealer locator at www.landpride.com.
3. Some new equipment installed during repair requires safety labels to be affixed to the replaced component as

specified by Kubota. When ordering new components make sure the correct safety labels are included in the request.

4. Refer to this section for proper label placement. To install new labels:
 - a. Clean surface area where label is to be placed.
 - b. Spray soapy water onto the cleaned area.
 - c. Peel backing from label and press label firmly onto the surface.
 - d. Squeeze out air bubbles with edge of a credit card or a similar type of straight edge.

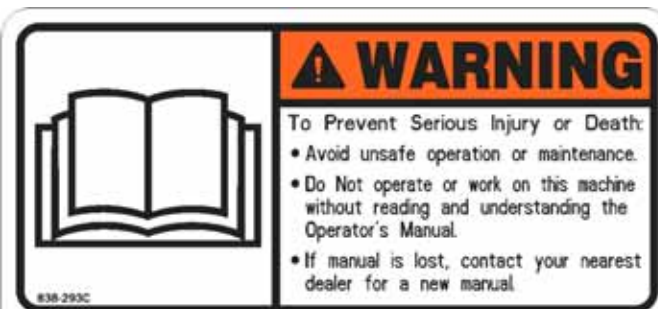
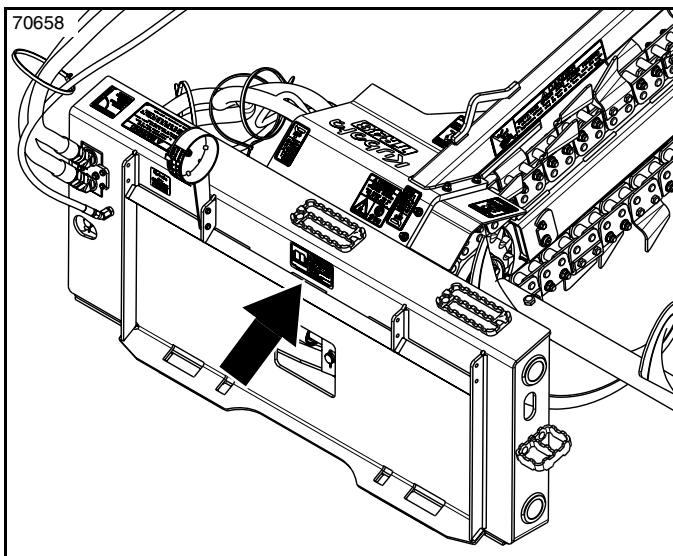

838-293C
Warning: Read Operator's Manual
1 Place

70243

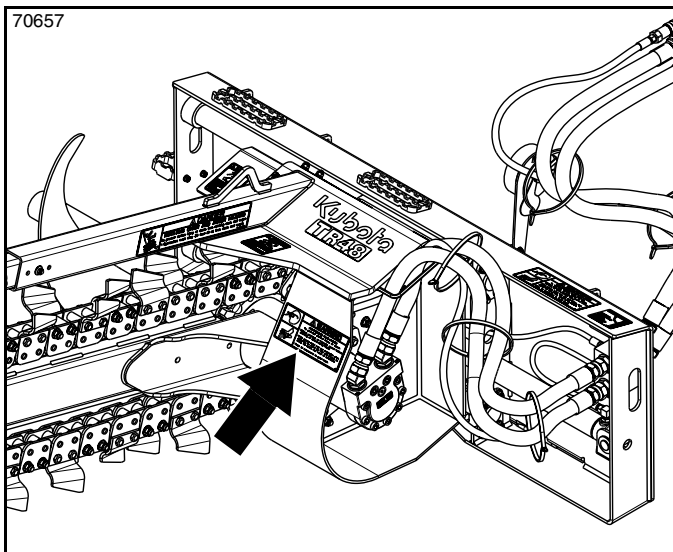

818-831C
Warning: High Pressure Fluid Hazard
1 Place

70659

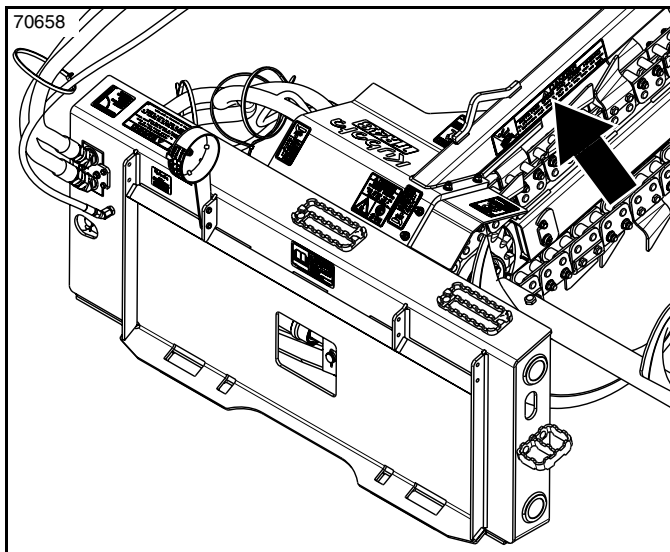

72085

858-722C

Danger: Rotating Chain and Auger Hazard
 2 Places

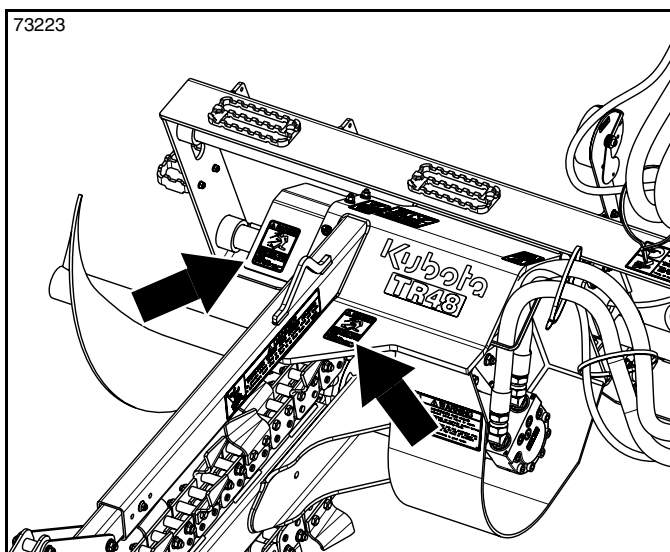
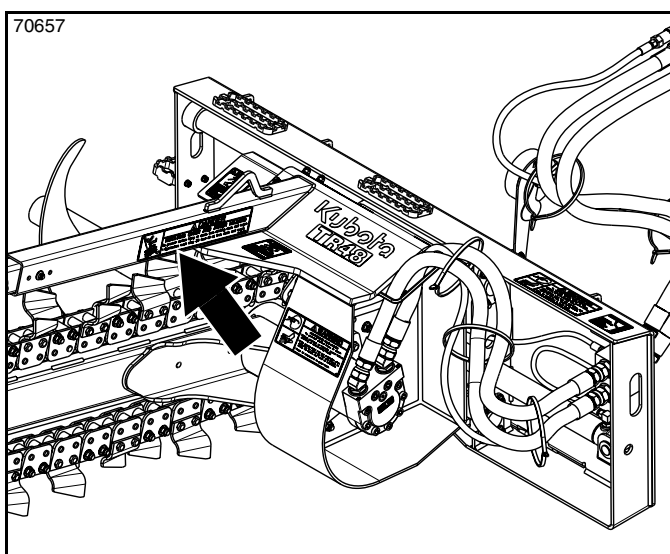

70640

818-132C

Danger: Thrown Object Hazard
 2 Places

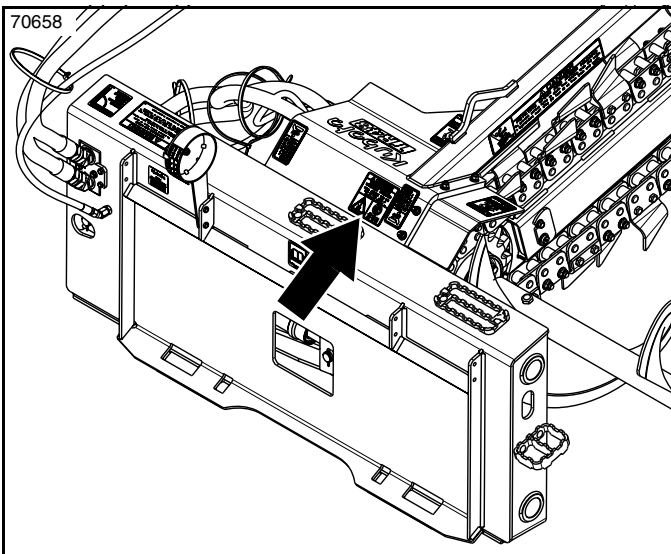
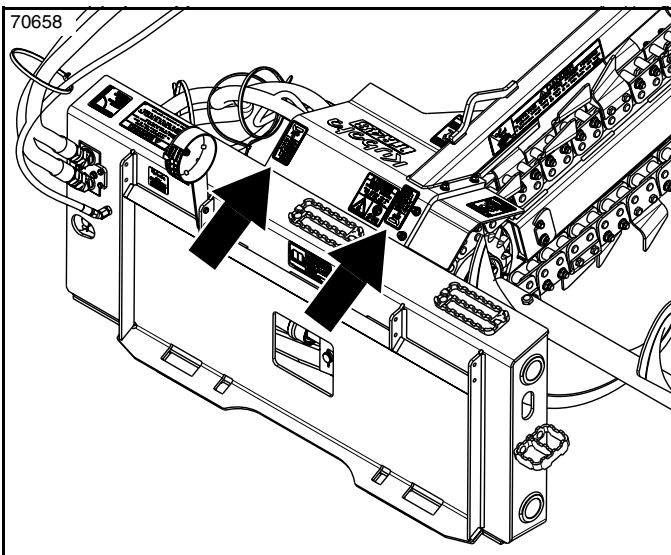
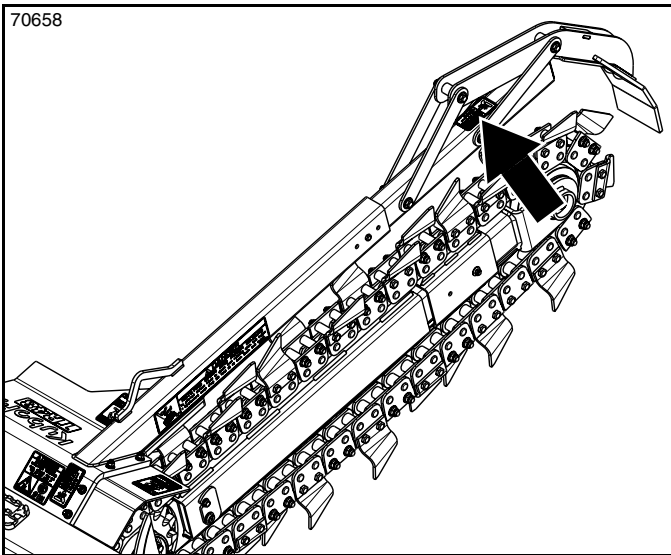

70369

818-798C
Warning: Pinch Point Hazard
3 Places



72928

844-194C
Danger: Underground Utilities Hazard
1 Place

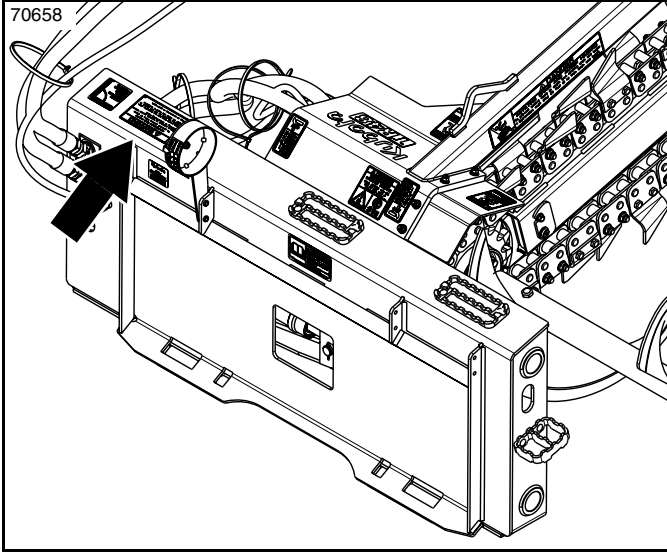

70659

818-831C

Warning: High Pressure Fluid Hazard
1 Place

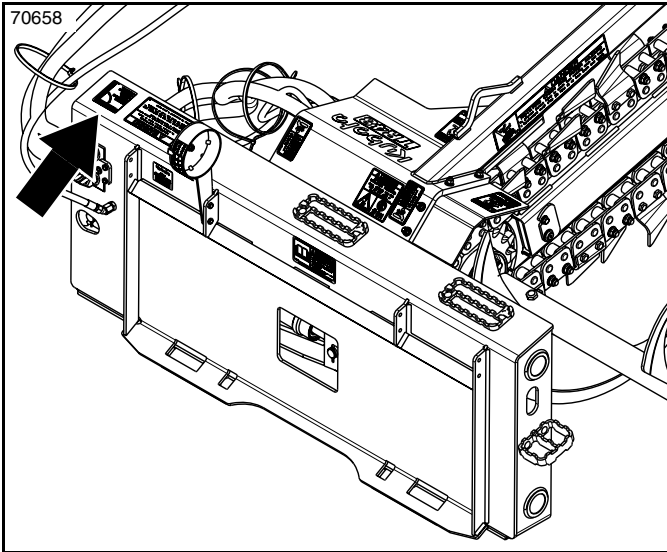

70661

858-915C

Notice: Hydraulic Pressure Hazard
1 Place

Introduction

Kubota welcomes you to the growing family of new product owners. This trencher has been designed with care and built by skilled workers using quality materials. Proper assembly, maintenance, and safe operating practices will help you get years of satisfactory use from this product.

Application

Kubota's TR Series Trenchers are available in two models. The Model TR48 can dig a trench up to 48" (1.22 m) deep and Model TR60 can dig a trench up to 60" (1.52 m) deep. Both models are available with either a 15-24 gpm (57-91 Lpm) motor or 24-40 gpm (91-151 Lpm) motor and feature four different chain styles. This contractor-grade trencher will make quick work of trenching runs for pipe, cable, electrical, or irrigation.

The TR Series Trencher comes complete with a standard 15 1/2" (39 cm) diameter spoil auger, crumber shoe, and grease-charged tensioning cylinder. The trencher chain will side shift up to 22" (56 cm) hydraulically or manually.

Chain options are offered in 2 or 4 pitch cup teeth for clay, sandy, or lightly compacted soils. Alligator or scorpion teeth chains with 50 percent cup teeth are offered for highly compacted or rocky soils. All chain options are available with 6" (15 cm), 8" (20 cm), or 10" (25 cm) widths.

See "Specifications & Capacities" on page 38 and "Features & Benefits" on page 39 for additional information and performance enhancing options.

Using This Manual

- This Operator's Manual is designed to help familiarize you with safety, assembly, operation, adjustments, troubleshooting, and maintenance. Read this manual and follow the recommendations to help ensure safe and efficient operation.
- The information contained within this manual was current at the time of printing. Some parts may change slightly to assure you of the best performance.
- To order a new Operator's or Parts Manual, contact your authorized dealer. Manuals can also be downloaded, free-of-charge, from our website at www.landpride.com

Terminology

"Right" or "Left" as used in this manual is determined by the direction the operator faces while sitting in the operator's seat looking forward unless otherwise stated.

Owner Assistance

The dealer should complete the Online Warranty Registration at the time of purchase. This information is necessary to provide you with quality customer service.

The parts on your trencher have been specially designed by Kubota/Land Pride and should only be replaced with genuine Kubota parts. Contact a Kubota dealer if customer service or repair parts are required. Your Kubota dealer has trained personnel, repair parts, and equipment needed to service this implement.

Serial Number

For quick reference and prompt service, record model and serial number on the inside cover page and again on the warranty page. Always provide model number and serial number when ordering parts and in all correspondence with your Kubota dealer. For location of your serial number plate, see Figure 1.

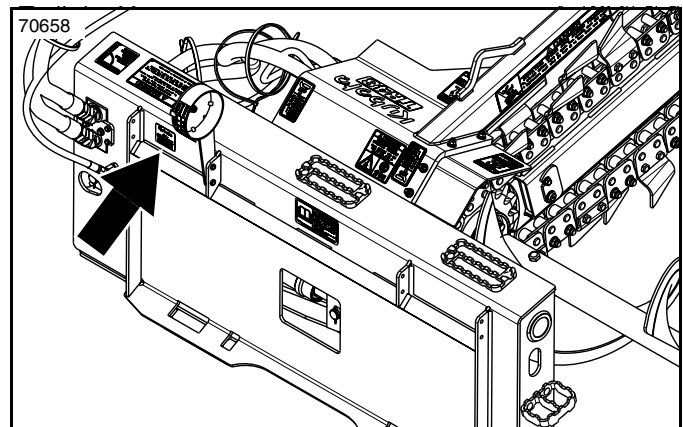

Trencher Serial Number Plate
Figure 1

Further Assistance

Your Kubota dealer wants you to be satisfied with your new attachment. If for any reason you do not understand any part of this manual or are not satisfied with the service received, the following actions are suggested:

1. If you have any issues or questions with your new attachment, please contact the service department at your local dealership to address your concerns.
2. If you are still not satisfied, seek out the owner or general manager of the dealership, explain the question/issue, and request assistance.
3. For further assistance write to:

**Kubota by Land Pride
Service Department**

**1525 East North Street
P.O. Box 5060
Salina, Ks. 67402-5060**

E-mail address
lpSERVICE@landpride.com

Section 1: Assembly & Set-up

Skid Steer/Track Loader Requirements

The attachment is designed to attach to skid steer and track loaders with the following minimum requirements:

- Hitch type
 - Skid steer type quick attach, meets ISO 24410
- Hydraulic motor flow rate
 - Low flow motor 15-24 gpm (57-91 Lpm)
 - High flow motor 24-40 gpm (91-151 Lpm)
- Recommended operating hydraulic pressure
 - 2400-3600 psi (16.5-24.8 MPa)
- Hydraulic Hose Couplers 1 male & 1 female
 - 15-24 gpm motor 1/2" flat face couplers
 - 24-40 gpm motor 3/4" flat face couplers
- Case drain hose 1 female CP 3/8" QD coupler
- Skid steer weight See warning below

WARNING

To avoid serious injury or death:

- *Lightweight power machines with a front loader attachment may need weight added to the rear to maintain steering control and prevent forward/side tipping. Consult your power machine Operator's Manual to determine proper weight requirements and maximum limitations.*
- *Consult your skid steer's manual for operating capacity, lifting capacity, and operating specifications. Exceeding rated capacities and specifications can result in a roll-over or other serious hazard.*

Torque Requirements

Refer to "Torque Values Chart" on page 51 to determine correct torque values when tightening hardware.

Before You Start

WARNING

To avoid serious injury or death:

Allow only persons to operate this attachment who have fully read and comprehended this manual, and who have been properly trained in the safe operation of this attachment. Serious injury or death can result from the inability to read, understand, and follow instructions provided in this manual.

Make sure the intended skid steer conforms to the "Skid Steer Requirements" stated above. Read and understand the Operator's Manual for your trencher. An understanding of how it works will aid in the assembly and setup of your trencher.

Go through the "Pre-Assembly Checklist" on this page before assembling the trencher. Speed up your assembly task and make the job safer by having all needed parts and equipment readily at hand.

Pre-Assembly Checklist

| ✓ | Check | Reference |
|--------------------------|--|---|
| <input type="checkbox"/> | Have a forklift or loader with properly sized chains and safety stands capable of lifting and supporting the equipment on hand. | |
| <input type="checkbox"/> | Have a minimum of two people available during assembly. | |
| <input type="checkbox"/> | Make sure all major components and loose parts are shipped with the attachment. | Operator's Manual |
| <input type="checkbox"/> | Double check to make sure all parts, fasteners and pins are installed in the correct location to lessen the chance of using a bolt incorrectly. Refer to the Parts Manual if unsure. NOTE: All assembled hardware from the factory has been installed in the correct location. Remember location of a part or fastener if removed. Keep parts separated. | Operator's Manual 350-234MK Parts Manual 350-234PK |
| <input type="checkbox"/> | Make sure working parts move freely, bolts are tight and cotter pins are spread. | Operator's Manual |
| <input type="checkbox"/> | Make sure all components are installed and properly adjusted. | Page 10 |
| <input type="checkbox"/> | Make sure all safety labels are correctly located and legible. Replace if damaged. | Page 4 |

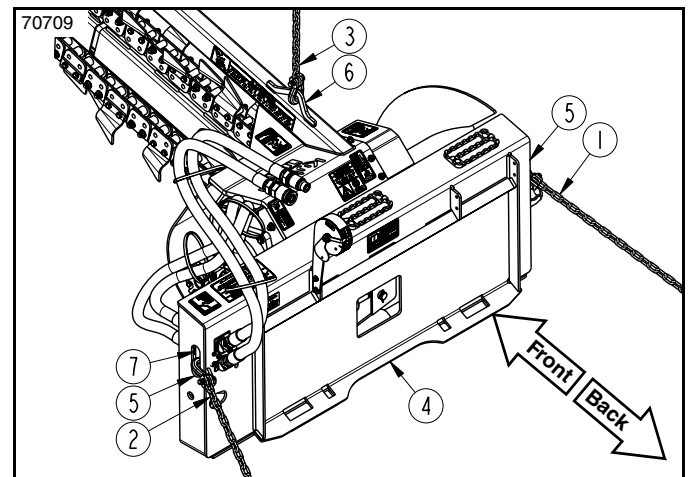

Chain Anchor Points
Figure 1-1

Lift / Transport Anchor Points

Refer to Figure 1-1:

When lifting the unit, hook chain (#3) to anchor point (#6).

IMPORTANT: Do not damage hydraulic components when transporting the trencher.

When anchoring the unit to a trailer, thread chain (#3) through anchor point (#6) and attach both ends of the chain to the trailer sides with the chain pulling the trencher forward.

Attach chains (#1 & #2) to anchor points (#5) on the sides of hitch (#4). Attach opposite ends of the chains to the trailer's right and left sides pulling the trencher backward.

Make sure the hook on chain (#2) does not make contact with hydraulic components (#7). If needed, use a chain with a smaller hook to avoid contact.

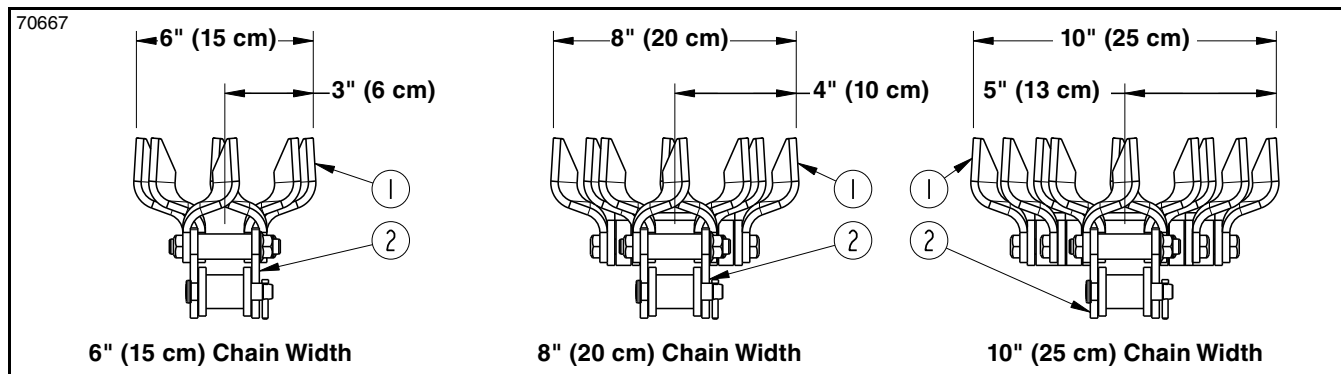

Three Nominal Chain Width Options Are Available

Figure 1-2

Dealer Preparation and Set-up

The trencher is shipped from the factory completely assembled with one of three chain widths (6", 8" or 10"). Verify the side auger is positioned properly and crumber shoe are sized and adjusted correctly to fit the chain shipped with the unit.

Check Chain Overall Width

Refer to Figure 1-2:

1. Locate the farthest tooth (#1) away from chain (#2). Measure distance from center of chain to outside edge of the tooth. The nominal distance should be 3" (6 cm), 4" (10 cm), or 5" (13 cm).
2. Multiply nominal distance by 2 to determine chain width. Example:
 - a. If actual distance measured was 4 1/8" (10.4 cm), use 4" (10 cm) as the nominal distance.
 - b. Multiply nominal distance by 2 to arrive at the chain width. Example: 4" x 2 = 8" (10 cm x 2 = 20). The chain shipped with the unit would be an 8" (20cm) wide chain.

2. Change crumber shoe (#1) if dimension (B) is incorrect for the chain being used. Refer to "Crumber Shoe Maintenance" on page 38.

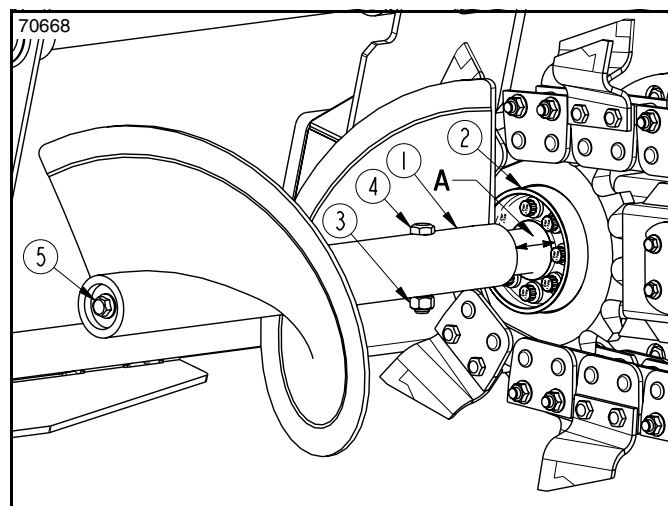

Auger Nominal Offset Spacing

Figure 1-3

Check Auger Offset

Refer to Figure 1-3:

1. Measure distance (A) from end of auger (#1) to the face of auger mount (#2). Nominal distance (A) should be as follows:
 - 6" (15 cm) chain width: A = 1 1/2" (4 cm)
 - 8" (20 cm) chain width: A = 2 1/2" (6 cm)
 - 10" (25 cm) chain width: A = 3 1/2" (9 cm)
2. Adjust auger (#1) if dimension (A) is incorrect for the chain being used. Refer to "Adjust Auger Position" on page 18.

Check Crumber Shoe Size

Refer to Figure 1-4:

1. Measure crumber shoe (#1) at its widest width (B). The width should be 1/2" (13 mm) smaller than the chain width.
 - 6" (15 cm) width: B = 5 1/2" (14 cm)
 - 8" (20 cm) width: B = 7 1/2" (19 cm)
 - 10" (25 cm) width: B = 9 1/2" (24 cm)

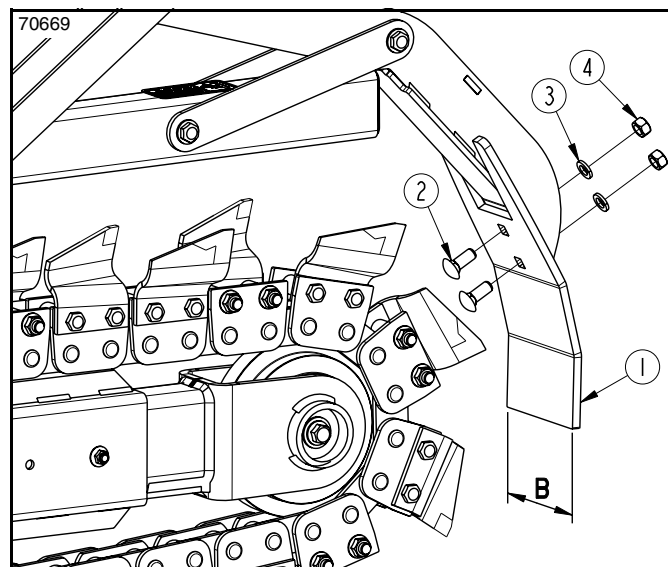

Crumber Shoe Size

Figure 1-4

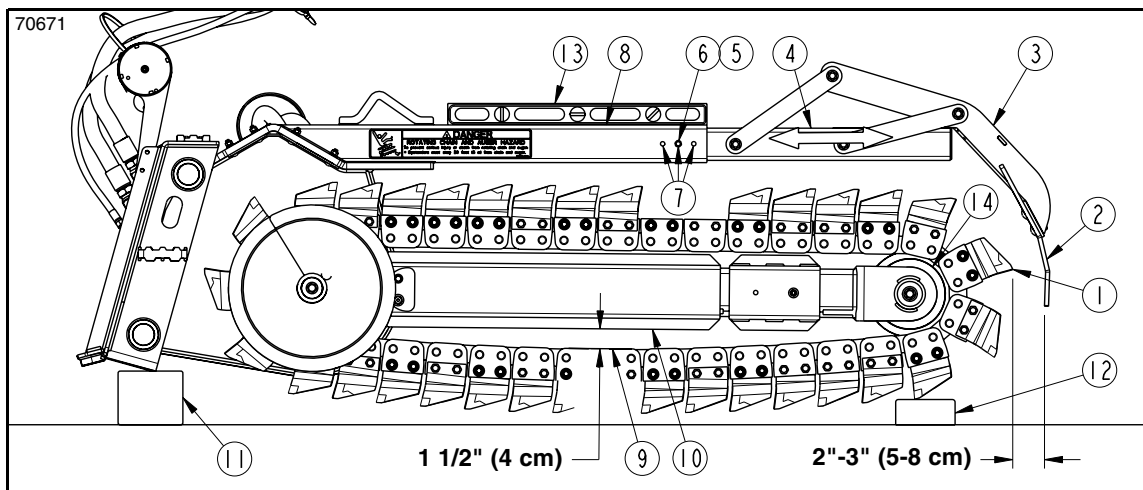

Crumber Arm Adjustment & Chain Tension
Figure 1-5

Check Chain Tension

Refer to Figure 1-5:

IMPORTANT: If the chain is too loose, it can jump off the drive sprocket or end roller causing damage to the unit. If the chain is too tight, it can cause increased chain and sprocket wear and require additional horsepower.

1. Connect trencher to a skid steer. Refer to “**Connect Trencher**” on page 14.
2. Lower loader arms until trencher hitch is resting on solid (non-concrete) support blocks (#11).
3. Place a level (#13) on the crumber support tube (#8). Tilt top of loader hitch plate forward or backward until crumber arm (#8) is level. The chain and teeth must be off the ground for the chain to hang freely.
4. Shut skid steer down before dismounting. Refer to “**Skid Steer/Track Loader Shutdown Procedure**” on page 16.
5. Place a solid support block (#12) under the front chain roller to keep the end from creeping down or dropping suddenly from loss of hydraulic pressure.
6. Measure clearance between top of lower chain (#9) and bottom of chain guide (#10). The clearance should be maintained around 1 1/2" (4 cm).
7. If trencher chain needs tensioning, refer to “**Adjust Chain Tension**” on page 19.

Attach Depth Indicator

Refer to Figure 1-6:

1. Make sure crumber arm (#8) is still level. If needed, repeat steps 1-4 above.
2. Attach depth indicator (#3) to gusset (#2) just left of anti-slip steps (#5) with two 5/16"-18 x 1" GR5 bolts (#1) and hex whiz nuts (#4A & #4B). Do not tighten nuts at this time.

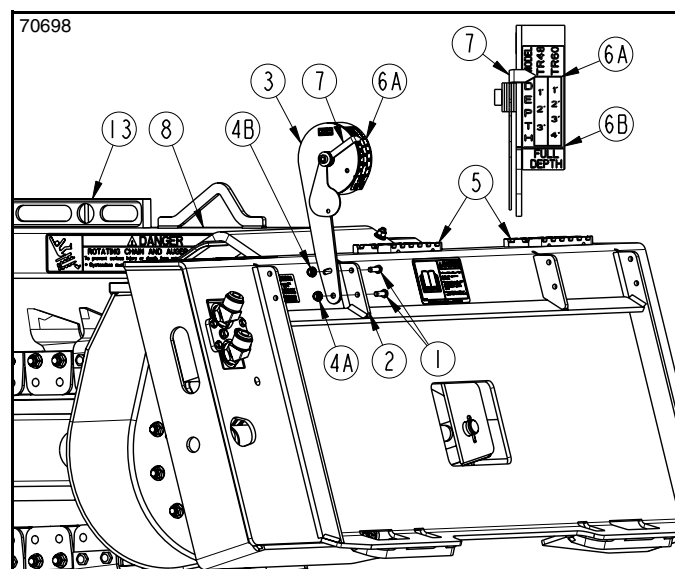

Depth Indicator
Figure 1-6

3. Pivot depth indicator (#3) about bolt (#4A) until pointer (#7) points to the top line (#6A) as shown in the enlarged illustration.
4. Tighten hex whiz nuts (#4A & #4B) to the correct torque for a 5/16"-18 GR5 bolt.

Check Crumber Arm Clearance

Refer to Figure 1-5:

1. Rotate crumber frame (#3) fully forward as shown.
2. Measure clearance from point of chain tooth (#1) to face of crumber shoe (#2). The clearance between the tooth and shoe should be 2" (5 cm) to 3" (8 cm).
3. If this clearance is less than 2" (5 cm) or more than 3" (8 cm), adjust crumber arm (#4) in or out.
4. For detailed instructions, refer to “**Adjust Crumber Arm**” on page 20.

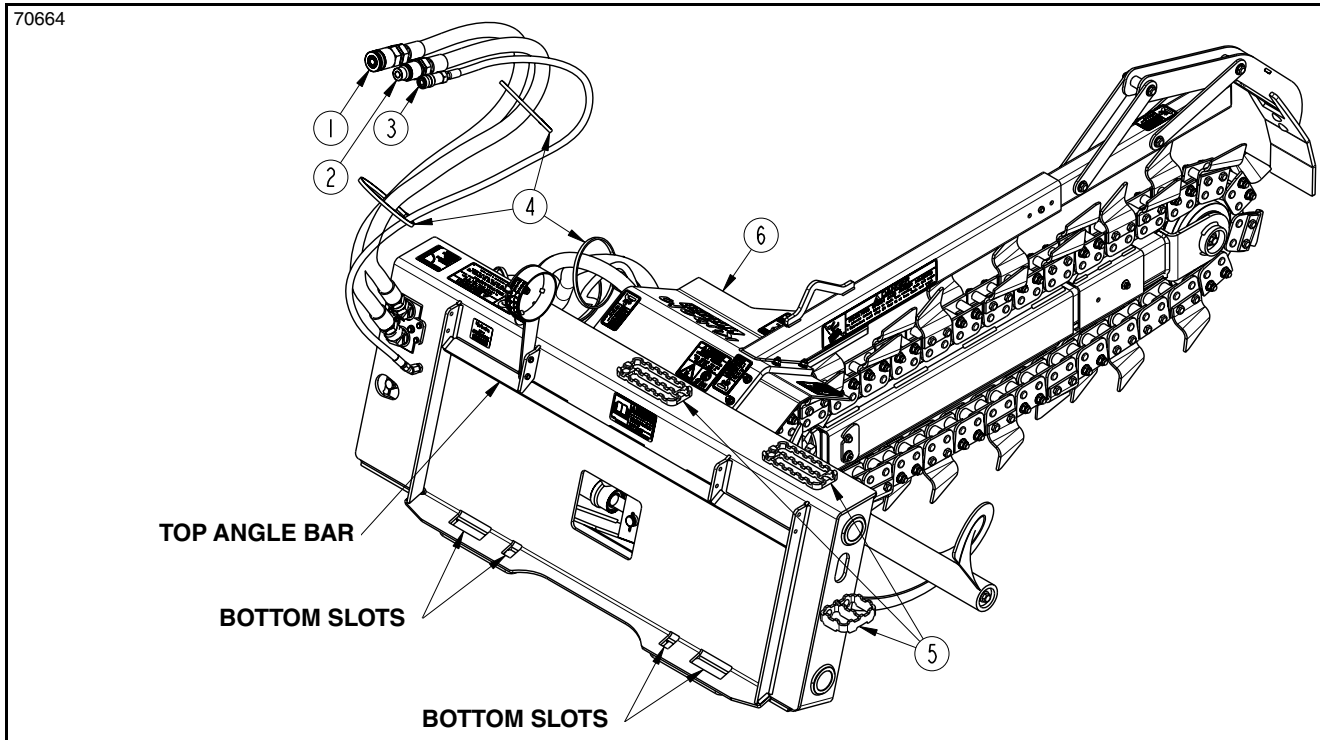

Connect Trencher
Figure 1-7

Connect Trencher

DANGER

To avoid serious injury or death:

- A crushing hazard exists when connecting and disconnecting the attachment. Do not allow anyone to stand between attachment and power machine while approaching or backing away from the attachment. Do not operate hydraulic controls while someone is near the power machine and/or attachment.
- Keep bystanders 20 feet (6 meters) away from the rotating chain and auger to avoid entanglement in them.

WARNING

To avoid serious injury or death:

- Use steps, grab-handles, and anti-slip surfaces on the power machine and attachment to get on and off the power machine. Using unapproved stepping surfaces and/or handholds can result in a falling hazard.
- Check hitch fit-up frequently. An improper fit-up can result in the attachment falling from the loader hitch plate.
- Lightweight power machines with a front loader attachment may need weight added to the rear to maintain steering control and prevent forward/side tipping. Consult your power machine Operator's Manual to determine proper weight requirements and maximum limitations.

Refer to Figure 1-7:

The trencher is designed for attaching to a skid steer or tractor loader with a skid steer type quick attach hitch that meets ISO 24410 standards.

1. Check skid steer and trencher hitch plates before hooking-up the trencher. Make sure all hitch components are in good working condition before putting them into service:
 - a. Check for and remove any debris in the front loader and trencher hitch plates.
 - b. Check for structural cracks in the hitch plates. Repair or replace hitch plates as needed.
 - c. Check hitch components. Repair or replace any part that is excessively worn, bent, broken, or missing.
 - d. Check operation of lock pins in the loader hitch plate. Lock pins must move freely and extend fully into the bottom slots in the trencher hitch plate.
2. If lock mechanism is mechanical, raise lock handles on the loader quick hitch fully up.
3. Start power machine.
4. If lock mechanism is hydraulic, use auxiliary hydraulic controls to raise the lock pins fully up.
5. Drive slowly to the trencher hitch plate making sure the quick attach hitch is parallel with the trencher's top angle bar.
6. Rotate top of loader hitch plate slightly forward.

Section 1: Assembly & Set-up

7. Place top of loader's quick attach hitch plate under the top angled bar on the trencher and slowly raise the loader hitch plate up until the loader hitch plate is seated under the top angle bar.
8. Rotate top of loader hitch plate back until the trencher hitch plate makes full contact with the face of the loader hitch plate and the trencher is slightly off the ground.
9. Engage lock mechanism:

Hydraulic Lock Mechanism:

 - a. Engage quick hitch locking mechanism hydraulically.

Mechanical Lock Mechanism:

 - a. Shut skid steer down before dismounting. Refer to "**Skid Steer/Track Loader Shutdown Procedure**" on page 16.
 - b. Push lock handles down to drive lock pins through bottom slots in the hitch plate. Make sure handles lock down.
 - c. Return to the power machine and lower the trencher until it is resting on the ground.
10. Shut the skid steer down before dismounting. Refer to "**Skid Steer/Track Loader Shutdown Procedure**" on page 16.
11. Use anti-slip steps (#5) on the trencher when stepping on and off the skid steer. Never use the motor shield (#6) as a step.

Connect Hydraulics

Refer to Figure 1-7:

DANGER

To avoid serious injury or death:

Make sure the skid steer has been properly shut down and pressure to the hydraulics has been relieved.

WARNING

To avoid serious injury or death:

- Hydraulic fluid under high pressure will penetrate the skin or eyes causing serious injury. Wear protective gloves and safety glasses or goggles when working with hydraulics. Use a piece of cardboard or wood, rather than hands, when searching for leaks. If an accident occurs, seek immediate emergency medical care or gangrene may result. **DO NOT DELAY.**
- Make sure hydraulic hoses are properly routed without twists to prevent them from becoming stretched, pinched, or kinked. A damaged hydraulic hose can burst and leak hydraulic fluid.
- Hydraulic fluid can become hot as it flows through components such as hydraulic couplers, hoses, lines, fittings, motors, etc. Wear gloves when working with hydraulic components including while connecting and disconnecting couplers. It is best to allow hydraulic components to cool before touching them.

IMPORTANT: Hose routing is the responsibility of the owner/operator. Pinched and/or stretched hoses are not covered under the warranty.

IMPORTANT: Make sure coupler fittings on the hydraulic hoses and power machine are clean before connecting them together.

1. Relieve all hydraulic pressure to auxiliary hydraulic lines.
2. Clean quick disconnect couplers of dirt and connect male and female couplers (#1 & #2) to the skid steer high-pressure outlets. Make sure they have fully engaged. If they have not, check the following:
 - Couplers are same size and type.
 - Hydraulic pressure is released.
3. Connect case drain coupler (#3) to the skid steer outlet. Make sure it is fully engaged.
4. Position hydraulic hoses where they do not become stretched, kinked, or pinched. If needed, add zip ties (#4) to the hoses to protect them from possible damage.

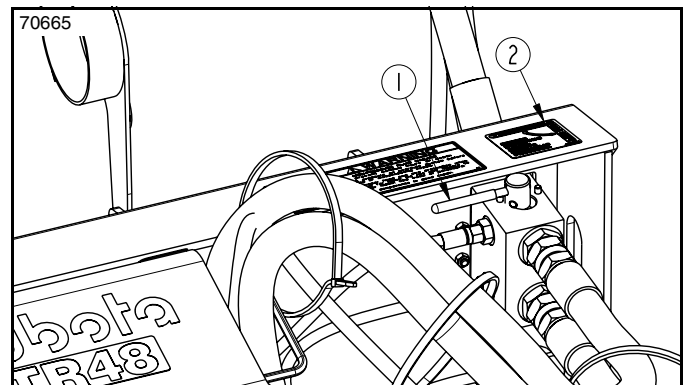

Remote Selector Valve in Optional Side Shift
Figure 1-8

5. Refer to Figure 1-8: If optional "**Hydraulic Side Shift**" is included, rotate remote selector valve lever (#1) clockwise until it stops in the trenching position shown. See decal (#2) for illustration of trenching and side shift positions of the lever.
6. Start the skid steer and raise trencher slightly off the ground.
7. With the skid steer idle, engage auxiliary hydraulics to check trencher chain movement. The chain should move away from the operator on top and toward the operator at the bottom.
8. Shut the skid steer down before dismounting. Refer to "**Skid Steer/Track Loader Shutdown Procedure**" on page 16.
9. If the trencher chain moved in the opposite direction, switch male and female couplers on the hydraulic hoses and then reconnect hoses to the outlets.

Equipment Clearances

It is important to check equipment clearances and hydraulic hose routing before putting the trencher into operation. Carefully go through the trencher's full range of motions to make sure the trencher does not make contact with the skid steer frame, tires, and hydraulic hoses. Check hydraulic hoses to make sure they do not stretch, kink, or pinch.

WARNING

To avoid serious injury or death:

- Use steps, grab-handles, and anti-slip surfaces on the power machine and attachment to get on and off the power machine. Using unapproved stepping surfaces and/or handholds can result in a falling hazard.
 - Check hitch fit-up frequently. An improper fit-up can result in the attachment falling from the loader hitch plate.
1. Before starting the skid steer, check hitch connection. The attachment can fall from the loader hitch plate if not properly connected.
 - a. Make sure loader hitch is fully seated under the trencher's top angle bar.
 - b. Make sure loader hitch plate is against the trencher hitch plate.
 - c. Make sure lock handles or hydraulic locks are locked with lock pins fully seated in the bottom slots.
 - d. Make sure there are no structural cracks in the hitch plates. Structural cracks weaken the hitch plate and can result in dropping the attachment.
 - e. Make sure there are no bent plates preventing full and complete connection to the loader hitch plate.
 2. Side shift trencher fully to the right while watching the hydraulic hoses to make sure they do not become stretched, pinched or kinked. Refer to "**Side Shift Trencher**" on page 17 for detailed instructions.
 3. If necessary, have someone stand nearby that can motion for the operator to stop if a problem develops.
 4. With the trencher on the ground, start skid steer and carefully rotate the top of the loader hitch plate fully back while watching hydraulic hoses to make sure they do not become pinched or kinked.
 5. Carefully raise loader arms up while tilting the top of the hitch fully forward to rotate the front of the trencher down. Watch hydraulic hoses to make sure they do not stretch, pinch, or kink.
 6. Continue to raise loader arms fully up and tilting the loader hitch fully forward while watching to make sure the attachment does not make contact with the skid steer or skid tires. Watch hydraulic hoses to make sure they do not stretch, pinch, or kink.
 7. Rotate top of hitch plate back and lower loader arms until trencher is resting on the ground.

8. Shut skid steer down before dismounting. Refer to "**Skid Steer/Track Loader Shutdown Procedure**" below.
9. Recheck hydraulic hoses. If needed, add zip ties to the hoses to protect them from possible damage.

Skid Steer/Track Loader Shutdown Procedure

The following are basic skid steer shutdown procedures. Follow these procedures and any additional shutdown procedures provided in your skid steer Operator's Manual before leaving the operator's seat.

1. Reduce engine speed and shut-off all power to the attachment.
2. Park on solid, level ground and lower attachment until it is flat on the ground or on non-concrete support blocks.
3. Turn off engine. Do not remove ignition key at this time.
4. Turn ignition key to the "RUN" position and relieve all hydraulic pressure by moving both joysticks.
5. Turn ignition key off and remove to prevent unauthorized starting.
6. If included, raise seat bar and move controls until both lock.
7. Wait for all components to come to a complete stop before leaving the operator's seat.
8. Use steps, grab-handles and anti-slip surfaces when stepping on and off the power machine and attachment.

Section 2: Adjustments

Side Shift Trencher

WARNING

To avoid serious injury or death:

Keep body, body extremities, loose clothing, pull strings, etc. away from pinch points such as rotating, extending, and/or retracting components. Secure pinch point areas to ensure they will not move before working on or near them.

The trencher, when shifted fully to the left, can side shift from center alignment up to 22" to the right hydraulically or manually.

1. Stop skid steer and trencher on solid, level ground.
2. Lower loader arms fully down.
3. Continue with “Manual Side Shift Option” below or “Hydraulic Side Shift Option” on page 18.

Manual Side Shift Option

Refer to Figure 2-1:

NOTE: Clamp (#2) in Figure 2-1 may be removed only if shifting the drive mount (#4) fully to the right.

Clamp (#3) in Figure 2-2 may be removed only if shifting the drive mount (#4) fully to the left.

Always replace clamp (#2 or #3) when side shifting the drive mount away being fully right or fully left.

1. Tilt top of hitch plate back to raise trencher chain and drive mount (#4) off the ground 2" to 3".
2. Shut skid steer down before dismounting. Refer to “Skid Steer/Track Loader Shutdown Procedure” on page 16.
3. Clean side shift rods (#5) of all dirt and trash.
4. Lubricate all exposed surfaces of the side shift rods (#5) with dry lubricant. Make sure you do this on both sides of drive mount (#4).
5. On the right-hand side, loosen hex head bolts (#1) and slide clamp (#2) to the right the distance you intend to side shift drive and chain assembly.
6. Tighten hex bolts (#1) to the correct torque for a 3/8"-16 GR5 bolt.
7. There are two methods to side shift the unit. Method-1 is preferred. Use method-2 only if Method-1 does not work.

Method-1:

- a. Manually push drive mount (#4) to the right until against clamp (#2) in Figure 2-1.

Method-2:

- a. Tilt top of hitch forward until unit is resting on the chain and drive mount (#4).
- b. Disconnect loader from the trencher. Refer to “Disconnect Trencher” on page 25.

IMPORTANT: Do not push against side step (#6) as that can damage the step.

- c. Position skid steer hitch plate against the right side of the trencher hitch plate. Do not push against the side step (#6).
- d. Gently push on trencher hitch plate until drive unit (#4) comes against clamps (#2).
- e. Connect skid steer hitch plate to the trencher hitch plate. Refer to “Connect Trencher” on page 14.

Refer to Figure 2-2:

8. Loosen hex head bolts (#1) and slide clamp (#3) on the left side until it is against drive frame (#4).
9. Tighten hex bolts (#1) to the correct torque for a 3/8"-16 GR5 bolt.
10. Repeat steps 5-9 to move drive mount (#4) to the left except start by sliding clamps (#3) to the left the distance you intend to side shift the unit.
11. Start skid steer and complete one of the following bullets below:
 - Lift trencher up to a low carrying height and begin transporting to the work site.
 - Tilt top of hitch plate forward until chain is resting on the ground. Shut skid steer down using “Skid Steer Shutdown Procedures” on page 14.

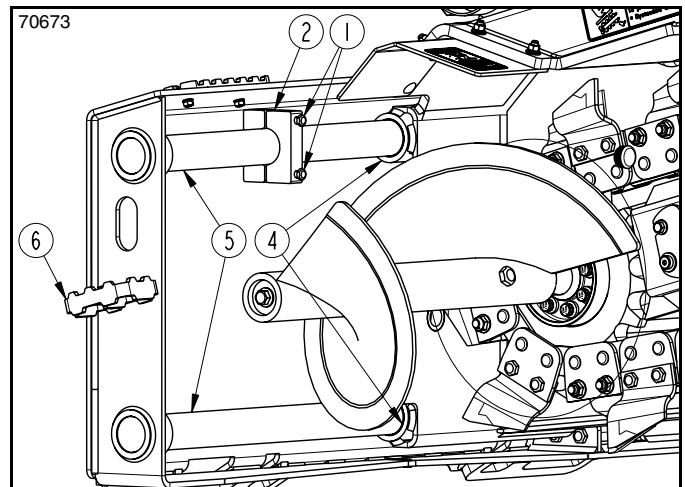

Manual Side Shift (Right-Hand Side)
Figure 2-1

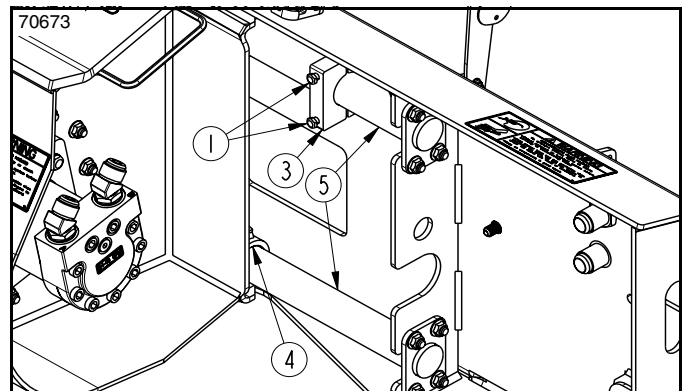

Manual Side Shift (Left-Hand Side)
Figure 2-2

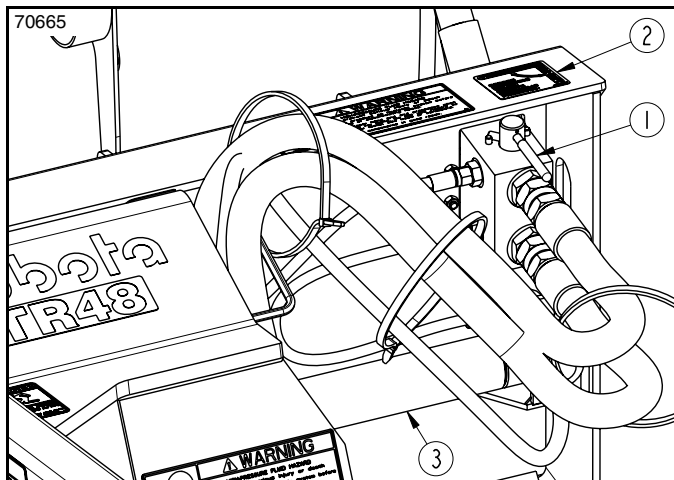

Remote Selector Valve in Optional Side Shift
Figure 2-3

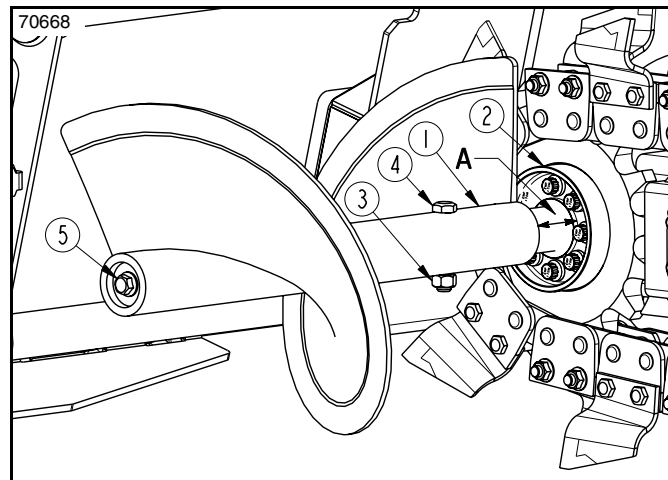

Auger Nominal Offset Spacing
Figure 2-4

Hydraulic Side Shift Option

Refer to Figure 2-3:

1. Shut skid steer off and relieve all auxiliary hydraulic pressure to the trencher before dismounting. Refer to “**Skid Steer/Track Loader Shutdown Procedure**” on page 16.
2. To side shift, rotate remote selector valve lever (#1) counterclockwise until it stops in the side shift position. See decal (#2) for illustration.
3. Restart skid steer and tilt top of hitch plate back to raise the trencher chain off the ground.
4. Operate skid steer auxiliary port variable switch to extend hydraulic cylinder (#3) and shift drive mount (#4) right or left up to 22”.
5. Rotate top of hitch plate forward until trencher chain is resting on the ground.
6. Shut skid steer off and relieve all auxiliary hydraulic pressure to the trencher before dismounting. Refer to “**Skid Steer/Track Loader Shutdown Procedure**” on page 16
7. Rotate remote valve lever (#1) clockwise until it stops in the trenching position as shown.

Adjust Auger Position

Refer to Figure 2-4:

1. Measure distance (A) from end of auger tube (#1) to the inside face of auger mount (#2). Nominal distance (A) should be as follows:
 - 6" (15 cm) chain width: A = 1 1/2" (4 cm)
 - 8" (20 cm) chain width: A = 2 1/2" (6 cm)
 - 10" (25 cm) chain width: A = 3 1/2" (9 cm)
2. If dimension (A) is incorrect, adjust auger (#1) as follows:
 - a. Remove nut (#3), bolt (#4), and auger (#1).
 - b. With gloves on, hand move auger side to side while rotating it to work it off the shaft.

NOTE: If auger does not move, remove bolt (#5) and install a puller to loosen the auger. The puller consists of a 1/2"-13 x 20" long all thread rod with a nut welded to one end. Insert threaded rod into the threaded bolt hole until auger is removed. Use nut to turn threaded rod.

- c. Clean auger shaft, inside of auger, and install anti-seize to the auger shaft.
- d. Reinstall auger (#1) and slide it to the correct distance (A).
- e. Replace bolt (#4) and secure with hex nut (#3). Tighten hex nut to the correct torque for a 5/8"-11 GR5 bolt.
- f. If removed, install hex flange bolt (#5) and tighten to the correct torque for a 1/2"-13 GR8 bolt.

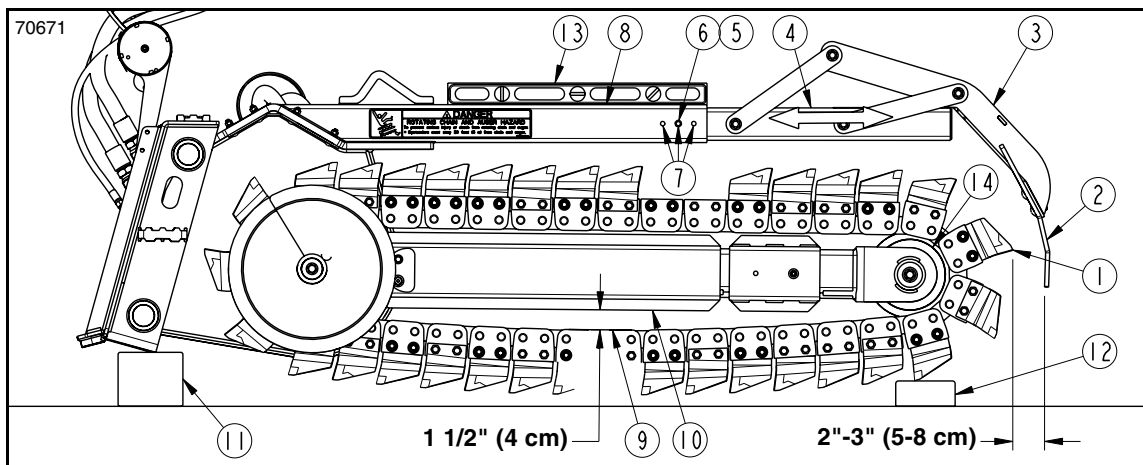

Crumber Arm Adjustment & Chain Tension
Figure 2-5

Adjust Chain Tension

Refer to Figure 2-5 on page 19:

WARNING

To avoid serious injury or death:

Lube fittings for the chain tensioner may be under high pressure. Wear proper protective equipment and stand to one side of the fittings when zerk and bleeder screw are exposed. Keep bystanders on the opposite side of the boom. Always use correct fittings when replacing the zerk or bleeder screw.

IMPORTANT: If the chain is too loose, it can jump off the drive sprocket or end roller causing damage to the trencher and its drive components. If the chain is too tight, it can cause increased chain and sprocket wear and require additional horsepower.

1. Stop skid steer and trencher on solid, level ground.
2. Lower loader arms until trencher hitch is resting on solid (non-concrete) support blocks (#11).
3. Tilt top of loader hitch plate forward or backward until trencher arm is horizontal. The chain and digging teeth must be off the ground for the chain to hang freely.
4. Shut skid steer down before dismounting. Refer to “**Skid Steer/Track Loader Shutdown Procedure**” on page 16.
5. Place a solid support block (#12) under the front chain roller to keep the roller end from creeping down or dropping suddenly from loss of hydraulic pressure.
6. Measure clearance between top of lower chain (#9) and bottom of lower chain guide (#10). Maintain clearance dimension around 1 1/2" (4 cm).

Refer to Figure 2-5 & Figure 2-6:

IMPORTANT: Do not remove bolts (#15 & #16) as the hydraulic cylinder is attached with these two

7. Loosen top hex flange bolt (#15) and bottom shoulder bolt (#16). Rotate zerk cover (#17) down.

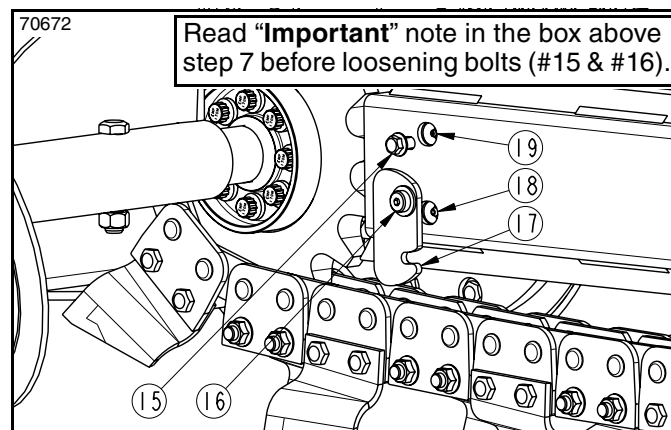

Chain Tension
Figure 2-6

8. Tension chain as follows:
 - Tighten Chain Tension**
 - a. Tighten brake bleeder screw (#18).
 - b. Add grease to zerk (#19) until chain slack is approximately 1 1/2" between top of lower chain (#9) and bottom of chain guide (#10).
 - Loosen Chain Tension:**
 - a. To assist clean up, install a short piece of 1/4" poly tube over the brake bleeder screw (#18) to direct grease into a holding container.
 - b. Loosen brake bleeder screw (#18) to allow grease to escape.
 - c. If needed, push in on chain roller (#14) to force the grease out.
 - d. Tighten brake bleeder screw when chain slack is 1 1/2" (4 cm) between top of lower chain (#9) and bottom of chain guide (#10).
9. Rotate zerk cover (#17) up and secure with hex flange bolt (#15). Tighten hex flange bolt (#15) and shoulder bolt (#16) to the correct torque for a 3/8"-16 GR8 bolt.

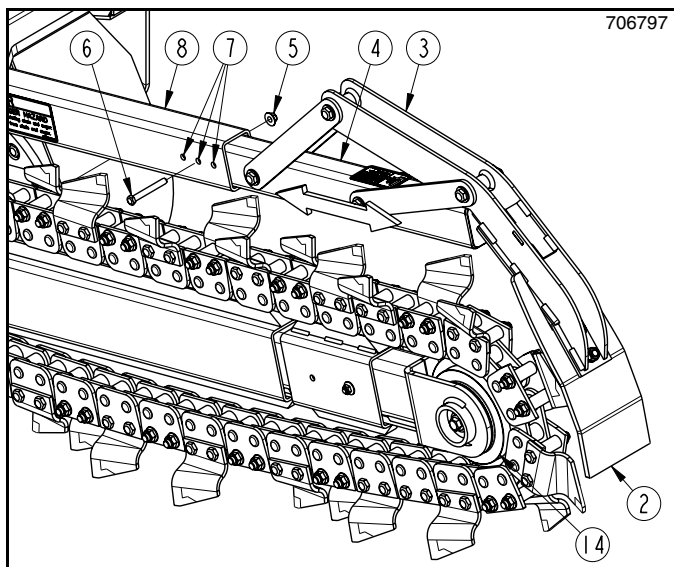

Adjust Crumber Arm
Figure 2-7

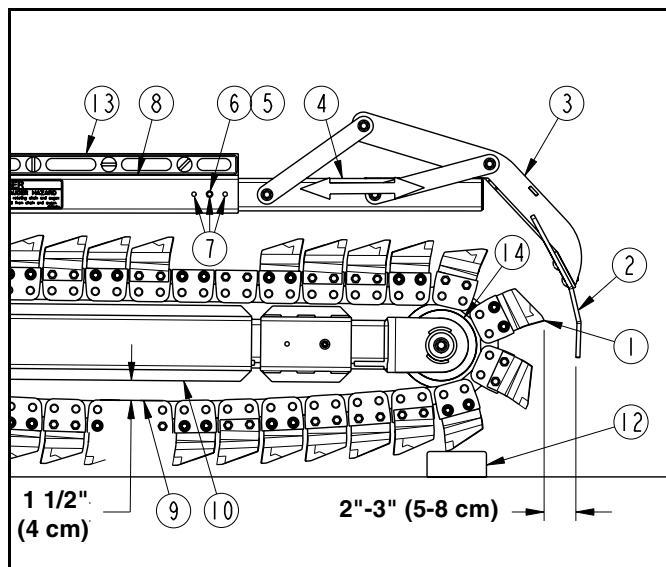

Adjust Crumber Arm
Figure 2-8

Adjust Crumber Arm

Refer to Figure 2-7 & Figure 2-8:

1. Complete “Adjust Chain Tension” on page 19 before adjusting the crumber arm.
2. Rotate crumber frame (#3) fully forward as shown.
3. Measure clearance from point of chain tooth (#1) to face of crumber shoe (#2). The clearance between the tooth and shoe should be 2"-3" (5-8 cm).
4. If this clearance is less than 2" (5 cm) or more than 3" (8 cm), remove flange locknut (#5) and bolt (#6). Slide crumber arm (#4) in or out of tube (#8) as needed.
5. Insert bolt (#6) in one of the three holes (#7) and secure with hex flange locknut. Draw locknut up snug. Do not tighten.

Section 3: Operating Instructions

Operating Checklist

Hazard control and accident prevention are dependent upon the awareness, concern, prudence, and proper training involved in the operation, transport, storage, and maintenance of the trencher. Therefore, it is absolutely essential that no one operates the trencher unless they have read, fully understood, and are totally familiar with the Operator’s Manual. Make sure the operator has paid particular attention to:

- **Important Safety Information**, page 1
- **Section 1: Assembly & Set-up**, page 10
- **Section 2: Operating Instructions**, page 17
- **Section 3: Adjustments**, page 20
- **Section 4: Maintenance & Lubrication**, page 24

Perform the following inspections before using your trencher.

Operating Checklist

| ✓ | Check | Page |
|---|---|------|
| | Make sure all guards and shields are secured in place. Refer to “Important Safety Information.” | 1 |
| | Inspect hydraulic hoses for wear, damage and hydraulic leaks. Replace damaged and worn hoses with genuine Kubota parts. | 3 |
| | Check initially and periodically for proper chain tension. Refer to “Adjust Chain Tension” | 19 |
| | Check side shift bars for lubrication. Refer to “Lubrication Points”. | 45 |
| | Check initially and periodically for loose bolts and pins. Refer to “Torque Values Chart”. | 51 |

General Safety Information

DANGER

To avoid serious injury or death:

- Always secure equipment with solid, non-concrete supports before working under it. Never go under equipment supported by concrete blocks or hydraulics. Concrete can break, hydraulic lines can burst, and/or hydraulic controls can be actuated even when power to the hydraulics is off.
- Keep bystanders 20 feet (6 meters) away from the rotating chain and auger to avoid entanglement in them.
- Never make contact with underground utilities such as electrical power lines, gas lines, phone lines, etc. They can cause serious injury or death from electrocution, explosion, or fire. Always call 811 (USA) or local utility companies before digging so that they can mark the location of underground services in the area. For contact information, see Dig Safe in the “Important Safety Information” starting on page 1.
- Keep attachment and/or loader arms away from overhead electrical power lines. Place an orange warning sign under overhead lines indicating type of danger above.

- Do not drive close to ditches, retaining walls, drop-offs, water, etc. Rollover due to a cave-in or mishap could result.
- Do not drive up to anyone or an animal in front of a fixed object such as a wall or bench. Never assume that the power machine will stop in time.
- Use a “spotter” when it is hard to see in the direction you are traveling and when placing a load that obstructs your vision. A person or animal could be nearby in a blind spot.

WARNING

To avoid serious injury or death:

- Never carry riders on the attachment or power machine. Riders can obstruct the operator’s view, interfere with controls, be pinched by moving components, become entangled in rotating components, struck by objects, thrown about, fall off and be run over, etc.
- Keep body, body extremities, loose clothing, pull strings, etc. away from pinch points such as rotating, extending, and/or retracting components. Secure pinch point areas to ensure they will not move before working on or near them.
- Do not alter attachment or replace parts on the attachment with other brands. Other brands may not fit properly or meet OEM (Original Equipment Manufacturer) specifications. They can weaken the integrity and impair the safety, function, performance, and life of the attachment. Replace parts only with genuine OEM parts.
- Avoid driving over freshly filled holes or trenches. The soil may not be compacted and allow tires or tracks to sink making the power machine unstable.
- Check hitch fit-up frequently. An improper fit-up can result in the attachment falling from the loader hitch plate.
- Use steps, grab-handles, and anti-slip surfaces on the power machine and attachment to get on and off the power machine. Using unapproved stepping surfaces and/or handholds can result in a falling hazard.
- Allow only persons to operate this attachment who have fully read and comprehended this manual, and who have been properly trained in the safe operation of this attachment. Serious injury or death can result from the inability to read, understand, and follow instructions provided in this manual.
- Operate only power machines equipped with a certified Roll-Over Protective Structure (ROPS) and seat belt. Fasten seat belt snugly and securely to help protect against serious injury or death from machine overturn.
- Hydraulic fluid under high pressure will penetrate the skin or eyes causing serious injury. Wear protective gloves and safety glasses or goggles when working with hydraulics. Use a piece of cardboard or wood, rather than hands, when searching for leaks. If an accident occurs, seek immediate emergency medical care or gangrene may result. **DO NOT DELAY.**

Section 3: Operating Instructions

- *Lube fittings for the chain tensioner may be under high pressure. Wear proper protective equipment and stand to one side of the fittings when zerk and bleeder screw are exposed. Keep bystanders on the opposite side of the boom. Always use correct fittings when replacing the zerk or bleeder screw.*
- *Make sure safety labels are in their proper location and are in good condition before operating the attached implement. Read and obey all instructions on the labels.*
- *Protect freshly dug trenches immediately after digging by covering the trench with a cover capable of supporting a person, or place a physical boundary around the trench to stop entry into the area.*
- *Make sure controls are all in neutral position or park before starting the power machine.*
- *Do not abuse equipment. Incorrect use of the attachment can damage equipment structurally and cause serious injury or death.*
- *Do not use this attachment to lift, carry, push or tow other equipment or objects. It is not properly designed or guarded for this use. The operator could lose control resulting in equipment damage and/or tipping hazard.*
- *Do not use this attachment to wrap wire or other items. Doing so can cause bodily injury and/or equipment damage.*
- *Avoid hitting solid objects with this attachment. Solid objects can damage equipment and throw the operator forward causing loss of control, bodily injury, or death.*
- *Do not abuse equipment. Incorrect use of the attachment can damage equipment structurally and cause serious injury or death.*
- *Avoid exposure to dust containing crystalline silica particles. This dust can cause serious injury to the lungs (silicosis). Because crystalline silica is a basic component of sand and granite, many activities at construction sites produce dust containing crystalline silica. Trenching, sawing, and boring of material containing crystalline silica can produce dust containing crystalline silica.*

Equipment Inspection

Make the following inspections after attaching the trencher to the skid steer. Shut trencher down before making any inspections.

1. Park skid steer with trencher on a flat level surface.
2. Shut skid steer down before dismounting. Refer to **“Skid Steer/Track Loader Shutdown Procedure”** on page 16.
3. Check loader and trencher hitch plate for worn, damaged, cracked, or loose parts. Repair or replace parts before putting the equipment into service.
4. Check hitch fit-up. Make sure loader hitch is properly positioned under the attachment’s top angle bar, lock pins are fully seated and locked in the bottom slots, and connection points area is clear of debris.
5. Inspect hydraulic hoses for wear, damage and hydraulic leaks. Tighten loose connections. Replace damaged and worn hoses with genuine Kubota parts. Refer to **“Avoid High Pressure Fluids Hazard”** on page 3.
6. Inspect hydraulic hoses to make sure they do not stretch, pinch or kink. Refer to **“Equipment Clearances”** on page 16.
7. Start skid steer and check all controls and operating functions of the skid steer.

Transporting



WARNING

To avoid serious injury or death:

- *Lightweight power machines with a front loader attachment may need weight added to the rear to maintain steering control and prevent forward/side tipping. Consult your power machine Operator’s Manual to determine proper weight requirements and maximum limitations.*
 - *When traveling on public roadways, travel in such a way that faster moving vehicles may pass safely. Use hazard lights, clean reflectors, and a slow moving vehicle sign that is visible from the back to warn operators in other vehicles of your presence. Always comply with all federal, state, and local laws.*
 - *Always transport loads low to the ground to maintain stability of the skid steer/tractor.*
1. Raise trencher to a safe, low, traveling height that does not block your view.
 2. Avoid contacting ground with trencher while transporting. Stop power unit before adjusting trencher height.
 3. Select a safe ground speed when transporting from one area to another.
 4. Be sure to reduce ground speed when turning and leave enough clearance so the boom does not contact obstacles such as buildings, trees, or fences.
 5. Slow down when traveling over rough or hilly terrain.
 6. When traveling on roadways, transport in such a way that faster moving vehicles may pass you safely.

Section 3: Operating Instructions

Operating Guidelines

Digging trenches with your trencher is easier by following some simple guidelines.

DANGER

To avoid serious injury or death:

Do not allow bystanders or animals to be near the attachment, loader arms, or power machine during operation. Stop operation if bystanders are too close. They can be hit by thrown or falling objects, become entangled, crushed, ran over, etc.

WARNING

To avoid serious injury or death:

- Never carry riders on the attachment or power machine. Riders can obstruct the operator's view, interfere with controls, be pinched by moving components, become entangled in rotating components, struck by objects, thrown about, fall off and be run over, etc.
- Always operate attachment while seated with seat belt properly fastened around the operator. When equipped, always lower seat/lap bar(s). This will help protect the operator against rollovers and sudden stops.
- Protect freshly dug trenches immediately after digging by covering the trench with a cover capable of supporting a person, or place a physical boundary around the trench to stop entry into the area.
- Never make contact with underground utilities such as electrical power lines, gas lines, phone lines, etc. They can cause serious injury or death from electrocution, explosion, or fire. Always call 811 (USA) or local utility companies before digging so that they can mark the location of underground services in the area. For contact information, see Dig Safe in the "Important Safety Information" starting on page 1.

IMPORTANT: Do not apply side load to the trencher with the digging chain in the ground. Side load to the unit can damage the trencher and/or skid steer.

1. Thoroughly inspect the area for potential problems before digging a trench.
 - a. Contact local utility companies before digging so that they may mark the location of underground services in the areas. Refer to "**Dig Safe - Avoid Underground Utilities**" on page 2.
 - b. Mark obstructions with visible stakes or flags.
 - c. Identify emergency equipment and utility outlets that may need quick access. Make a plan on how not to block these areas so that emergency crews can access them quickly.

2. It is always best to dig a trench with the boom centered on the attachment. The farther it is side shifted away from center, the harder it is to guide the skid steer in a straight line while digging a trench.
3. Bring the trencher up to full speed before lowering the unit into the ground.
4. Start with the loader arms fully down, tilt the top of the hitch plate forward to start the trencher digging into the ground. At the same time, raise the loader arms as needed to keep the trencher from lifting the front of the skid steer off the ground.

IMPORTANT: The crumber shoe can be damaged if the trencher is forced to open a new trench without backing-up occasionally to allow the crumber shoe to drop.

5. Keep a watchful eye on the crumber shoe when opening up a new trench. If the crumber shoe starts to lift, back-up until it drops again. Continue this procedure until the trencher has reached its predetermined cutting depth. The goal is to get the trencher into the ground at full depth with minimum backing and without damaging the crumber shoe.
6. If attachment is to be operated in reverse, make sure visibility to the rear of the power unit is appropriate for the attachment.
7. Back in a straight line. Do not make turns with the trencher in the ground.
8. Stop backing if the trencher chain slows down or comes to a stop. If the chain does not pick up to full speed, perform the following steps below.
 - a. Raise trencher by tilting the top of the hitch plate back slightly.
 - b. If that does not work, raise the loader arms slightly.
 - c. If that did not work, jog the chain in reverse several times to free the chain.
 - d. Once full speed has returned, carefully lower trencher until at the predetermined depth.
9. Never travel parallel to the trench with the wheels close to the trench.

Section 3: Operating Instructions

General Operating Instructions

The first thing you want to do is to contact the local utility companies to have them locate all underground utilities. Refer to “**Dig Safe - Avoid Underground Utilities**” on page 2. Never cut into the utilities.

Next, you will want to predetermine your path. The best path is a straight line from start to finish. If a tree, building, or other obstacle prevents making a straight line, then mark out a path that will require as few corners as possible. Make sure the path allows clearance for the skid steer to pass by any obstacle while digging.

If you plan to start the trench next to a wall, dig an access hole at the required depth before digging the trench. If the trench ends at a wall, dig another access hole at that wall.

Align the skid steer with the back facing the end of the trench and the front at the start of the trench. With the skid steer at an idle, engage auxiliary hydraulics to start the trencher. Slowly increase throttle speed until full engine speed is reached.

If starting next to a wall, slowly lower the end of the trencher into the access hole by tilting the top of the hitch plate forward and raising the loader arms to keep from lifting the front of the skid steer off the ground. Continue this combination of tilting the hitch plate and lifting the loader arms until the required depth has been reached.

If starting in an open area, slowly lower the end of the trencher into the ground by tilting the top of the hitch plate forward and raising the loader arms to keep from lifting the front of the skid steer off the ground. Keep a watchful eye on the crumber shoe. When the crumber shoe starts to lift, back up the skid steer until the crumber shoe drops again. Continue this procedure of tilting the hitch plate, lifting the loader arms, and backing up until the required trench depth is reached.

If attachment is to be operated in reverse, make sure visibility to the rear of the power unit is appropriate for the attachment.

Back trencher up at a speed that allows the unit to dig without stalling. You will need to slow down in hard soil and rocky soil. If the trencher chain stops, stop backing-up. Usually the chain will recover its speed and you can resume backing at a slower speed. You may need to tilt the hitch plate back slightly, raise the loader arms slightly, or jog the chain in reverse several times to get the chain to break free and regain operation.

If the trench has a corner, continue digging past the corner until the end of the trencher has passed through the corner. Stop traveling and raise the trencher out of the ground, shut off hydraulic power to the trencher, and park the skid steer in an out of the way area.

You will want to open up the corner up with a backhoe before starting your next leg of the trench. Dig a hole on the corner and pile the dirt in an open area away from the second leg of the trench. When completed, park the backhoe and return to the skid steer.

If a backhoe is not available, you will need to align the back of the skid steer with the back facing the end of the second leg and the front of the trencher beyond the corner two or three feet. Start digging the same as if you were starting in an open area without an access hole. The trencher should reach full depth before crossing the previously dug trench. Manually clean out the corner with a trench shovel. The trench shovel can also be used to clean other areas of the trench.

If a backhoe was used, align the back of the skid steer with the back facing the end of the second leg and the front of the trencher at the start of the leg. Enter the hole dug at the corner with the trencher the same as you would enter an access hole. Continue backing in a straight line until the end of the trencher has passed the end of the second leg. Stop the skid steer and raise the trencher out of the ground. Shut off hydraulics to the trencher once the trencher is out of the ground.

If the trench ends next to a wall, stop traveling halfway through the dig. Turn the skid steer around and position the skid steer in front of the access hole at the wall. Enter the access hole as before and start digging backing-up and in line with the previously dug trench. Continue backing up until the end of the trencher has passed into the existing trench. Stop the skid steer and raise the trencher out of the ground. Shut off hydraulics to the trencher once the trencher is out of the ground. Raise the trencher to a low transport height and make a sharp turn backing up or traveling forward to cross over the trench. When you are finished, park the skid steer using “**Skid Steer Shutdown Procedures**” on page 14.

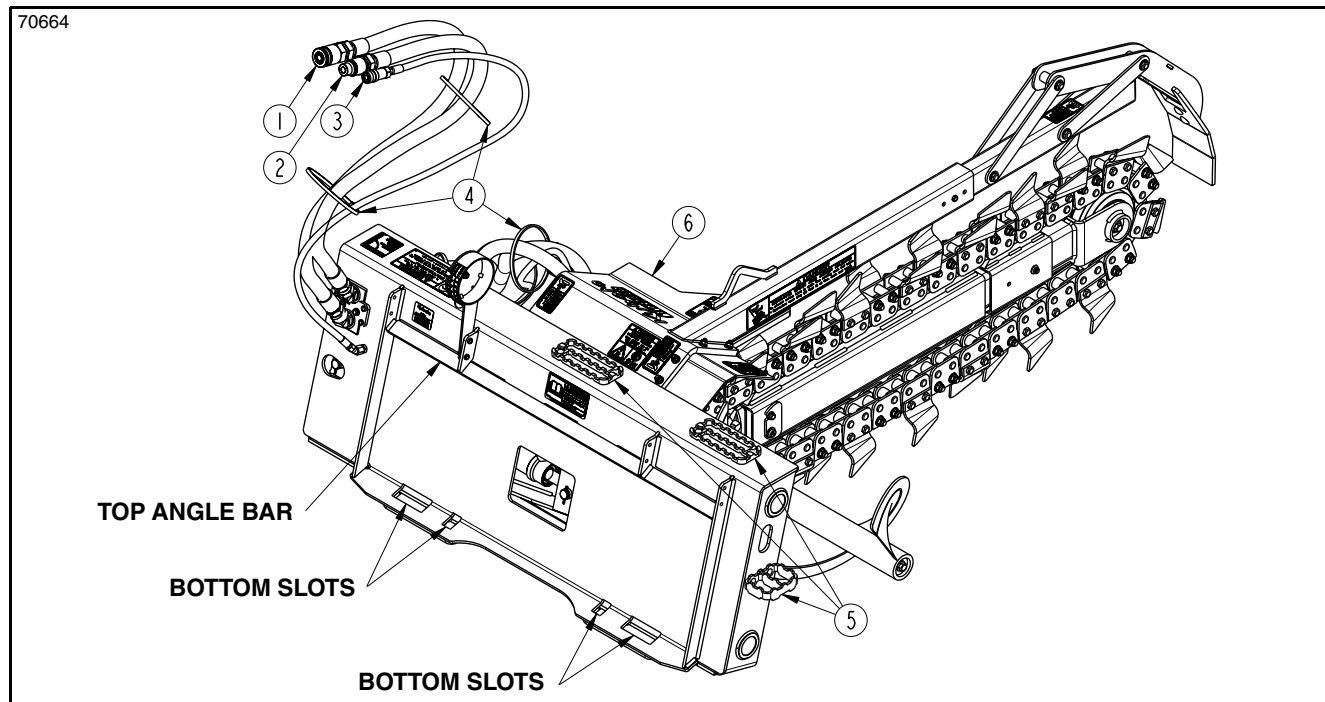

Disconnect Trencher
Figure 3-1

Disconnect Trencher

Refer to Figure 3-1:

DANGER

To avoid serious injury or death:

A crushing hazard exists when connecting and disconnecting the attachment. Do not allow anyone to stand between attachment and power machine while approaching or backing away from the attachment. Do not operate hydraulic controls while someone is near the power machine and/or attachment.

WARNING

To avoid serious injury or death:

- Hydraulic fluid under high pressure will penetrate the skin or eyes causing serious injury. Wear protective gloves and safety glasses or goggles when working with hydraulics. Use a piece of cardboard or wood, rather than hands, when searching for leaks. If an accident occurs, seek immediate emergency medical care or gangrene may result. **DO NOT DELAY.**
- Check hitch fit-up frequently. An improper fit-up can result in the attachment falling from the loader hitch plate.
- Shutdown power machine and release all hydraulic pressure to the equipment before connecting or disconnecting hydraulic hoses to or from the power machine.

- Park skid steer with attached trencher on solid, level ground.
- Lower trencher onto the ground or support blocks.
- Shut skid steer down before dismounting. Refer to “**Skid Steer/Track Loader Shutdown Procedure**” on page 16.
- Uncouple hydraulic hose fittings (#1, #2 & #3) from the skid steer. Coil hydraulic hoses and store them on the trencher with hose ends out of the dirt.
- If lock handles are mechanical, pull lock handles up on the loader hitch plate to remove lock pins from the bottom slots in the attachment’s hitch plate.
- Return to the skid steer seat.
- If lock handles are hydraulic, raise lock pins to remove them from the hitch plate bottom slots.
- Tilt top of loader hitch plate slightly forward to move bottom of loader hitch plate away from trencher hitch plate.
- Slowly lower the loader arms until the loader hitch plate has separated from the attachment’s top angle bar.
- Back skid steer slowly away from the trencher making sure the skid steer does not interfere with the attachment’s hitch plate or hydraulic hoses.

Crumber Shoe Option

Refer to Figure 4-1:

If changing out the chain to a different width, make sure you also change crumber shoe (#1) to match the chain width. Refer to “Crumber Shoe Maintenance” on page 38 for replacement instructions.

| # | Part No. | Description | Qty |
|---|----------|--------------------------|-----|
| 1 | 350-407D | Crumber Shoe 6" (15 cm) | 1 |
| 1 | 350-409D | Crumber Shoe 8" (20 cm) | 1 |
| 1 | 350-410D | Crumber Shoe 10" (25 cm) | 1 |

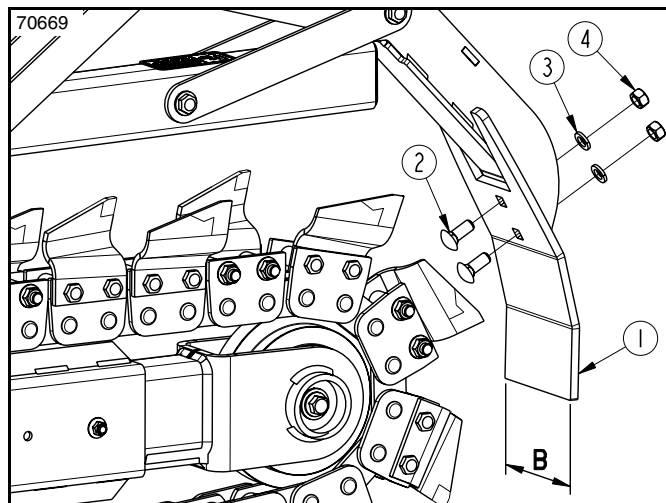

Crumber Shoe Size
Figure 4-1

Definitions

Chain Pitch: The distance from center of one chain roller to the center of an adjacent chain roller. The chain supplied with the TR48 and TR60 has a 2" (5 cm) chain pitch.

2 Pitch Spacing: Equals two chain pitches or 4" (10 cm).

4 Pitch Spacing: Equals four chain pitches or 8" (20 cm).

Station: Any location on the chain where a chain tooth may be attached. A station can have a chain tooth on one side of the chain or it can have two teeth if a tooth is mounted on each side of the chain.

IMPORTANT: A chain tooth must be attached with both mounting bolts going through the same chain link/station. Otherwise, the chain will not flex around the sprocket and end roller.

Chain and Cutter Tooth Recommendations for Various Digging Conditions

| Chain Configuration | Rocky Soil | Hard Soil | Medium Soil | Soft Soil | Sandy |
|--|------------|-----------|-------------|-----------|-------|
| Standard cup, 4 pitch spacing | — | — | Yes | Yes | Yes |
| Standard cup, 2 pitch spacing | — | Yes | Yes | Yes | Yes |
| Scorpion and cup teeth, 2 pitch spacing | Yes | Yes | Yes | Yes | — |
| Alligator and cup teeth, 2 pitch spacing | Yes | Yes | Yes | Yes | — |

NOTE: Chains with 2 pitch spacing have a tooth every station making them more efficient for cutting in hard soils or rocky soils. A chain with 4 pitch spacing has a tooth every other station. This allows the chain to cut smoothly through softer soils and sandy soils.

Trencher Chain Selection Options

Refer to Table above & Figure 4-2 on page 27:

IMPORTANT: To get the most efficient cut, use the table above to match chain configuration with type of soil the trencher will be digging. Your dealer can help when choosing a chain configuration.

Figure 4-2 on page 23 illustrates the different chains listed in the table. Chain part numbers and tooth mounting arrangements are illustrated on the following pages:

Refer to “Standard Cups, 2 Pitch Spacing” on page 28.

Refer to “Standard Cups, 4 Pitch Spacing” on page 30.

Refer to “Alligator and Cup Teeth” on page 32.

Refer to “Scorpion and Cup Teeth” on page 34.

70703

Standard cup with 2 pitch spacing,
cup tooth on every station

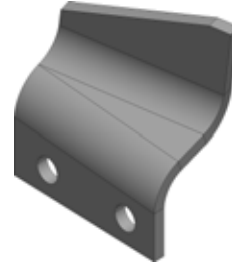
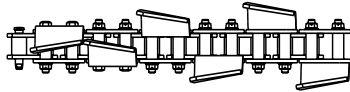

Standard cup with 4 pitch spacing,
cup tooth on every other station

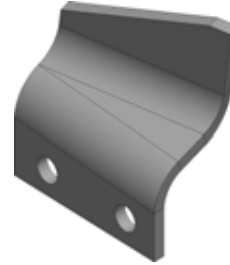
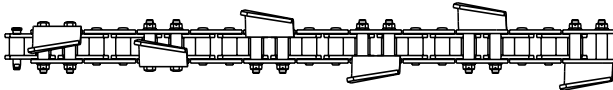

Alligator and cup teeth (50/50 combination)
with one or two teeth on every station

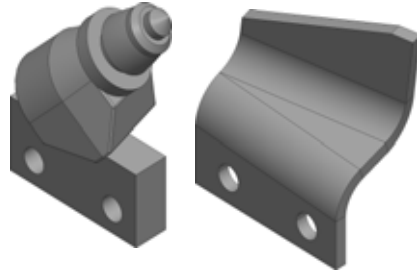
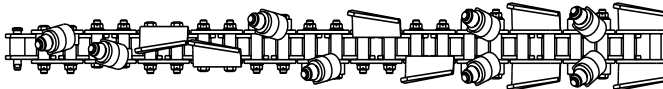

Scorpion and cup teeth (50/50 combination)
with one or two teeth on every station

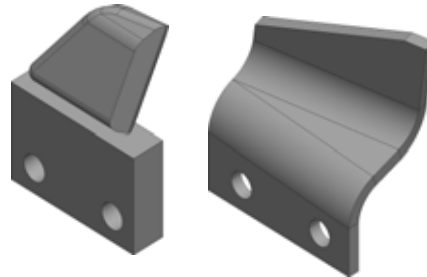
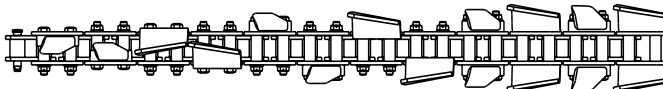

Chain Widths

6" (15 cm)

8" (20 cm)

10" (25 cm)

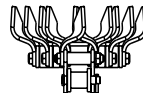
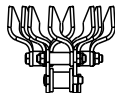

Trencher Chain Selection Guide
Figure 4-2

Standard Cups, 2 Pitch Spacing

Refer to Figure 4-3, Figure 4-4, & Figure 4-5:

Part numbers listed below are for complete chain assemblies. Purchase individual teeth and attaching hardware through your local Kubota dealer.

Part No. TR48 Standard Cups, 2 Pitch Spacing

- 350-072A 6" (15 cm) Standard cups with 2 pitch spacing
- 350-170A 8" (20 cm) Standard cups with 2 pitch spacing
- 350-171A 10" (25 cm) Standard cups with 2 pitch spacing

Part No. TR60 Standard Cups, 2 Pitch Spacing

- 350-129A 6" (15 cm) Standard cups with 2 pitch spacing
- 350-185A 8" (20 cm) Standard cups with 2 pitch spacing
- 350-186A 10" (25 cm) Standard cups with 2 pitch spacing

Part No. Description of Teeth

- 1 820-623C Cup tooth LH
- 2 820-624C Cup tooth RH
- 3 820-624C Cup tooth RH
- 4 820-623C Cup tooth LH
- 5 820-624C Cup tooth RH
- 6 820-623C Cup tooth LH
- 7 350-215H Spreader 8"
- 8 820-624C Cup tooth RH
- 9 820-623C Cup tooth LH
- 10 350-227H Spreader 10"
- 11 820-624C Cup tooth RH
- 12 820-623C Cup tooth LH

Part No. Description of Fasteners

- A 842-394C Hex head cap screw 1/2-20 x 3 1/4 GR8 PLT
- B 842-393C Hex head cap screw 1/2-20 x 3 GR8 PLT
- C 842-391C Hex head cap screw 1/2-20 x 2 1/4 GR8 PLT
- D 803-308C Nut hex flange lock 1/2-20 PLT GR G
- E 350-262D Spacer inside long 1.80"LG
- F 350-250D Spacer inside short 1.55"LG

TR48: Repeat cup arrangement 1-6 five times, then add 1-5. 35 Stations.

70674

TR60: Repeat cup arrangement 1-6 six times, then add 1-4. 40 Stations.

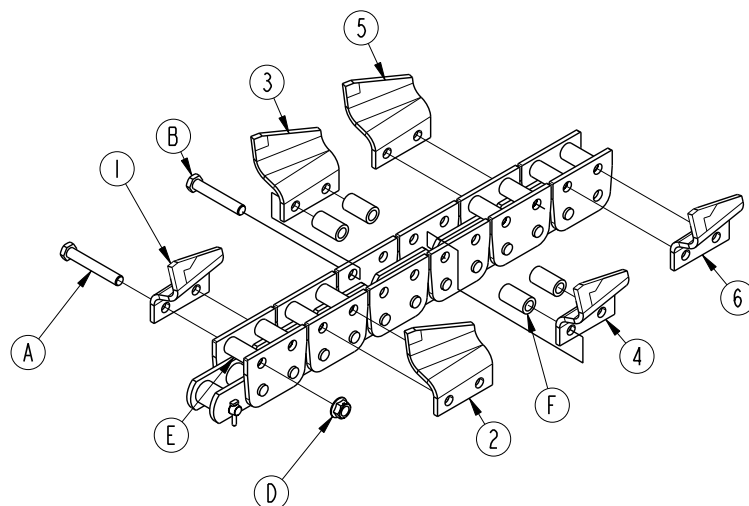

6" Standard Cups With 2" Spacing
Figure 4-3

TR48: Repeat cup arrangement 1-9 five times. 35 Stations.

70675

TR60: Repeat cup arrangement 1-9 five times, then add 1-5. 40 Stations.

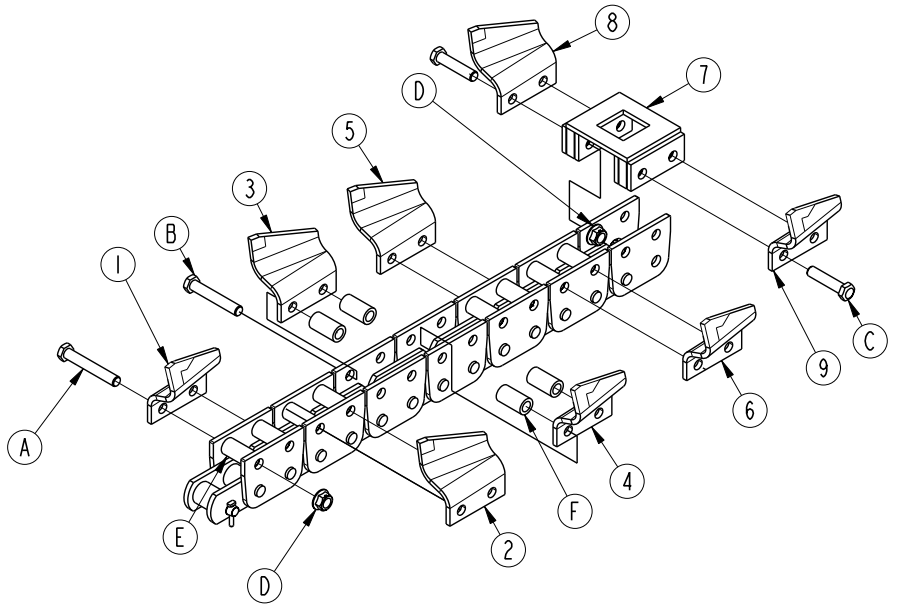

8" Standard Cups With 2" Spacing
Figure 4-4

TR48: Repeat cup arrangement 1-12 four times, then add 1-3. 35 Stations.

70676

TR60: Repeat cup arrangement 1-12 five times. 40 Stations.

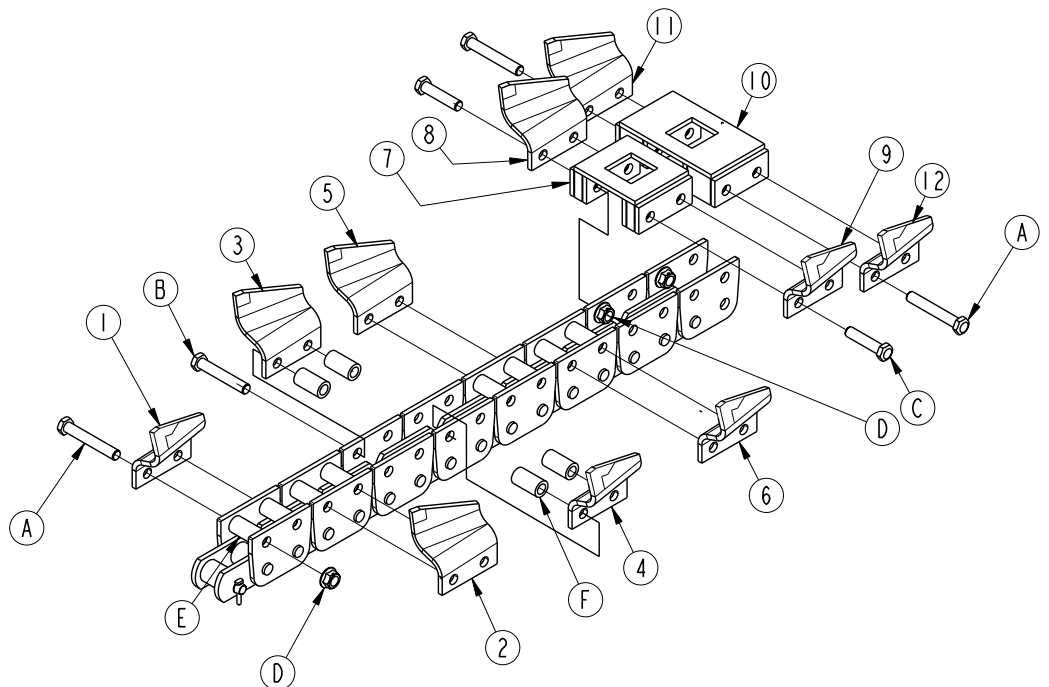

10" Standard Cups With 2" Spacing
Figure 4-5

Section 4: Options

Standard Cups, 4 Pitch Spacing

Refer to Figure 4-6, Figure 4-7, & Figure 4-8:

Part numbers listed below are for complete chain assemblies. Purchase individual teeth and attaching hardware through your local Kubota dealer.

Part No. TR48 Standard Cups, 4" Spacing

- 350-173A 6" (15 cm) Standard cups with 4 pitch spacing
- 350-174A 8" (20 cm) Standard cups with 4 pitch spacing
- 350-175A 10" (25 cm) Standard cups with 4 pitch spacing

Part No. TR60 Standard Cups, 4" Spacing

- 350-188A 6" (15 cm) Standard cups with 4 pitch spacing
- 350-189A 8" (20 cm) Standard cups with 4 pitch spacing
- 350-191A 10" (25 cm) Standard cups with 4 pitch spacing

Part No. Description of Teeth

- | # | Part No. | Description of Teeth |
|----|----------|-------------------------|
| 1 | 820-623C | Cup tooth LH |
| 2 | 820-624C | Cup tooth RH |
| 3 | 820-624C | Cup tooth RH |
| 4 | 820-623C | Cup tooth LH |
| 5 | 820-624C | Cup tooth RH |
| 6 | 820-623C | Cup tooth LH |
| 7 | 350-215H | Spreader 8" |
| 8 | 820-624C | Cup tooth RH |
| 9 | 820-632C | Blade Samurai 18 X .256 |
| 10 | 350-227H | Spreader 10" |
| 11 | 820-624C | Cup tooth RH |
| 12 | 820-623C | Cup tooth LH |

Part No. Description of Fasteners

- | # | Part No. | Description of Fasteners |
|---|----------|---|
| A | 842-394C | Hex head cap screw 1/2-20 x 3 1/4 GR8 PLT |
| B | 842-393C | Hex head cap screw 1/2-20 x 3 GR8 PLT |
| C | 842-391C | Hex head cap screw 1/2-20 x 2 1/4 GR8 PLT |
| D | 803-308C | Nut hex flange lock 1/2-20 PLT GR G |
| E | 350-262D | Spacer inside long 1.80"LG |
| F | 350-250D | Spacer inside short 1.55"LG |

TR48: Repeat cup arrangement 1-6 three times. 35 Stations with 18 stations used.

TR60: Repeat cup arrangement 1-6 three times, then add 1-2. 40 Station chain with 20 stations used.

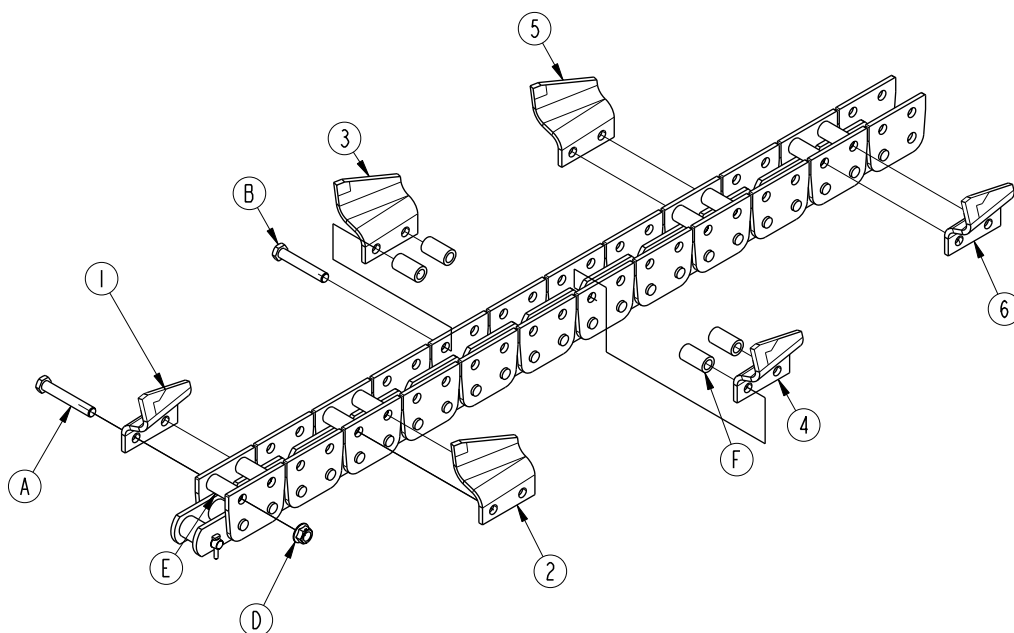

70677

6" Standard Cups With 4" Spacing
Figure 4-6

TR48: Repeat cup arrangement 1-9 two times, then add 1-4.
35 Station chain with 18 stations used.

TR60: Repeat cup arrangement 1-9 two times, then add 1-6.
40 Station chain with 20 stations used.

70678

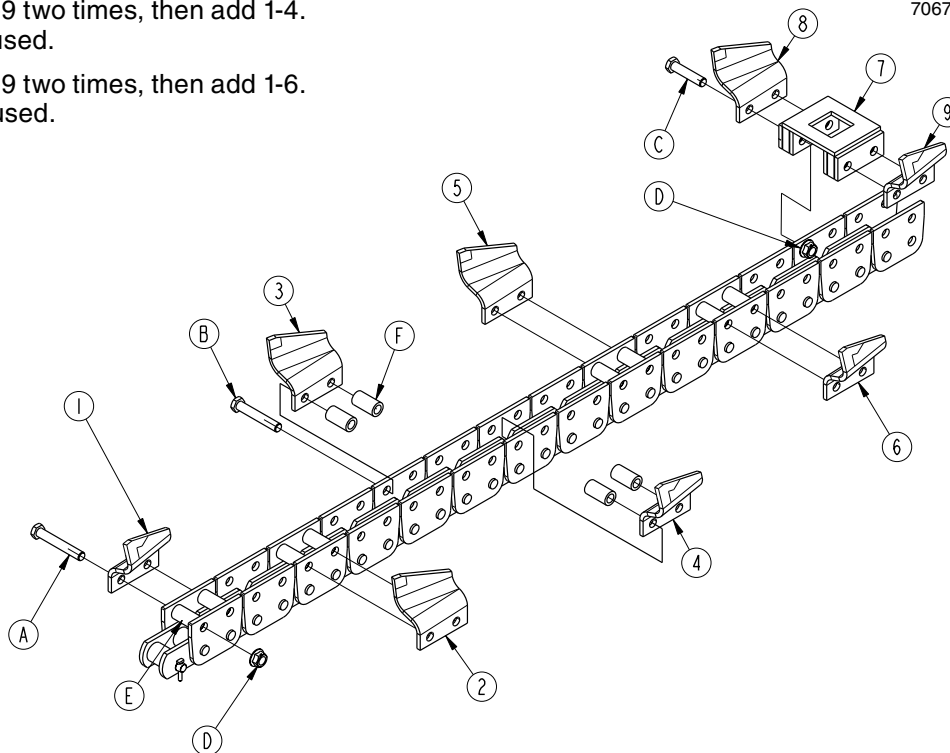

8" Standard Cups With 4" Spacing
Figure 4-7

TR48: Repeat cup arrangement 1-12 two times, then add 1-2.
35 Station chain with 18 stations used.

TR60: Repeat cup arrangement 1-12 two times, then add 1-4.
40 Station chain with 20 stations used.

70679

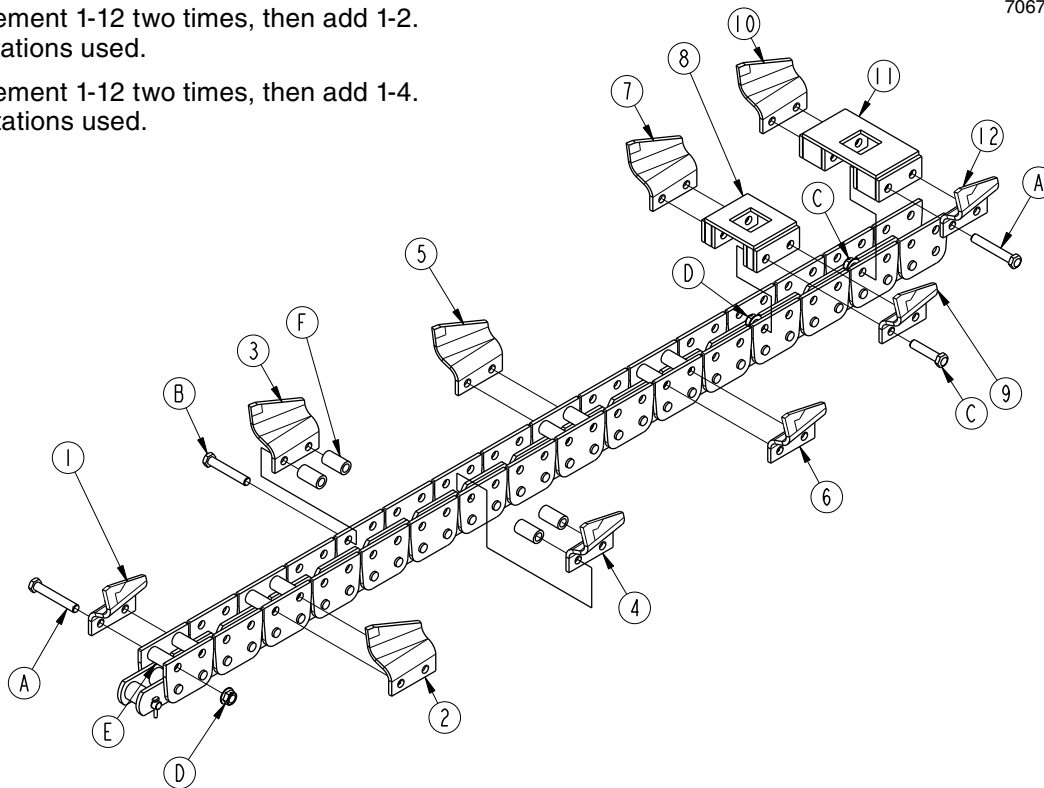

10" Standard Cups With 4" Spacing
Figure 4-8

Alligator and Cup Teeth

Refer to Figure 4-9, Figure 4-10, & Figure 4-11:

Part numbers listed below are for complete chain assemblies. Purchase individual teeth and attaching hardware through your local Kubota dealer.

Part No. TR48 Alligator and Cup Teeth

- 350-181A 6" (15 cm) Alligator & cup teeth w/ 2 pitch spacing
- 350-182A 8" (20 cm) Alligator & cup teeth w/ 2 pitch spacing
- 350-183A 10" (25 cm) Alligator & cup teeth w/ 2 pitch spacing

Part No. TR60 Alligator and Cup Teeth

- 350-199A 6" (15 cm) Alligator & cup teeth w/ 2 pitch spacing
- 350-201A 8" (20 cm) Alligator & cup teeth w/ 2 pitch spacing
- 350-202A 10" (25 cm) Alligator & cup teeth w/ 2 pitch spacing

Part No. Description of Fasteners

- A 842-393C Hex head cap screw 1/2-20X3 GR8 PLT
- B 842-394C Hex head cap screw 1/2-20X3 1/4 GR8 PLT
- C 842-438C Hex head cap screw 1/2-20X3 3/4 GR8 PLT
- D 842-395C Hex head cap screw 1/2-20X3 1/2 GR8 PLT
- E 842-439C Hex head cap screw 1/2-20X4 1/2 GR8 PLT
- F 842-392C Hex head cap screw 1/2-20X2 3/4 GR8 PLT
- G 842-391C Hex head cap screw 1/2-20X2 1/4 GR8 PLT
- H 842-438C Hex head cap screw 1/2-20X3 3/4 GR8 PLT
- J 803-308C Nut hex flange lock 1/2-20 PLT GR G
- K 350-445D Spacer inside 1.05"LG
- L 350-262D Spacer inside long 1.80"LG
- M 350-250D Spacer inside long 1.55"LG

Part No. Description of Teeth

- 1 820-644C Alligator LH CNT-4" bit holder (Stamped #7)
- 2 820-645C Alligator RH CNT-4" bit holder (Stamped #6)
- 3 820-623C Cup tooth LH
- 4 820-624C Cup tooth RH
- 5 820-645C Alligator RH CNT-4" bit holder (Stamped #6)
- 6 820-644C Alligator LH CNT-4" bit holder (Stamped #7)
- 7 820-624C Cup tooth RH
- 8 820-623C Cup tooth LH
- 9 820-647C Alligator RH 5" bit holder (Stamped #9)
- 10 820-646C Alligator LH 5" bit holder (Stamped #8)
- 11 820-624C Cup tooth RH
- 12 820-623C Cup tooth LH
- 13 820-649C Alligator RH 6" bit holder (Stamped #0)
- 14 820-648C Alligator LH 6" bit holder (Stamped #1)
- 15 820-624C Cup tooth RH
- 16 820-623C Cup tooth LH
- 17 820-647C Alligator RH 5" bit holder (Stamped #9)
- 18 350-215H Spreader 8"
- 19 820-646C Alligator LH 5" bit holder (Stamped #8)
- 20 820-624C Cup tooth RH
- 21 350-215H Spreader 8"
- 22 820-623C Cup tooth LH
- 23 820-647C Alligator RH 5" bit holder (Stamped #9)
- 24 350-227H Spreader 10"
- 25 820-646C Alligator LH 5" bit holder (Stamped #8)
- 26 820-624C Cup tooth RH
- 27 350-227H Spreader 10"
- 28 820-623C Cup tooth LH
- 29 820-652C Tip with clip

TR48: Repeat alligator and cup arrangement 1-16 two times, then add 1-14. 35 Station Chain.

TR60: Repeat alligator and cup arrangement 1-16 three times, then add 1-4. 40 Station Chain.

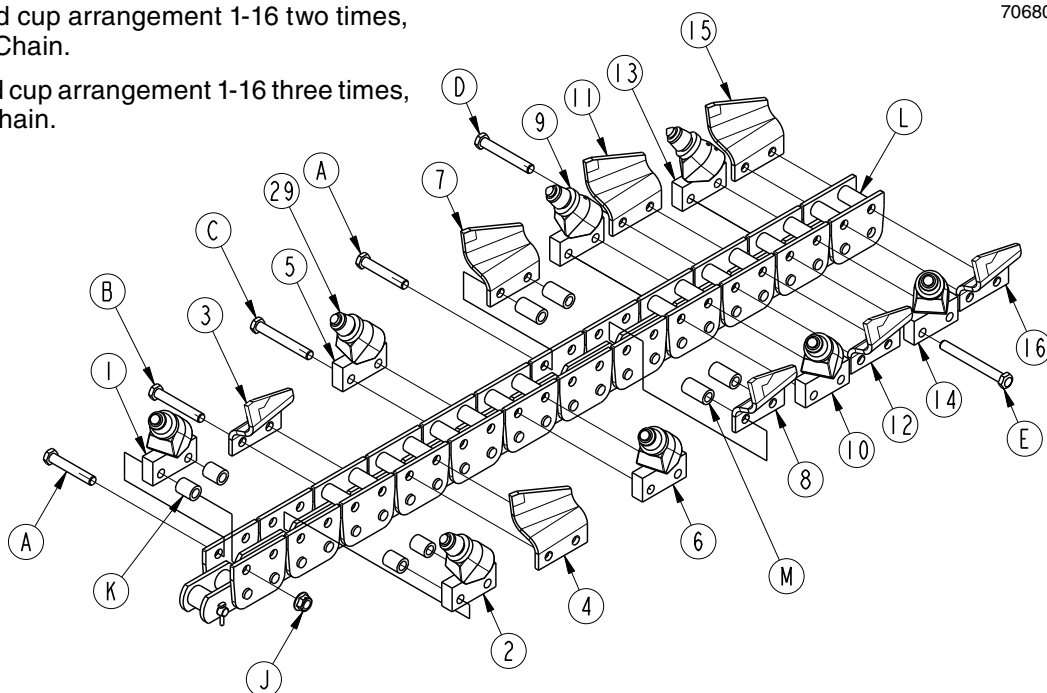

6" Alligator and Cup Teeth With 2 Pitch Spacing
Figure 4-9

TR48: Repeat alligator and cup arrangement 1-22 two times, then add 1-7. 35 Stations.

TR60: Repeat alligator and cup arrangement 1-22 two times, then add 1-16. 40 Stations.

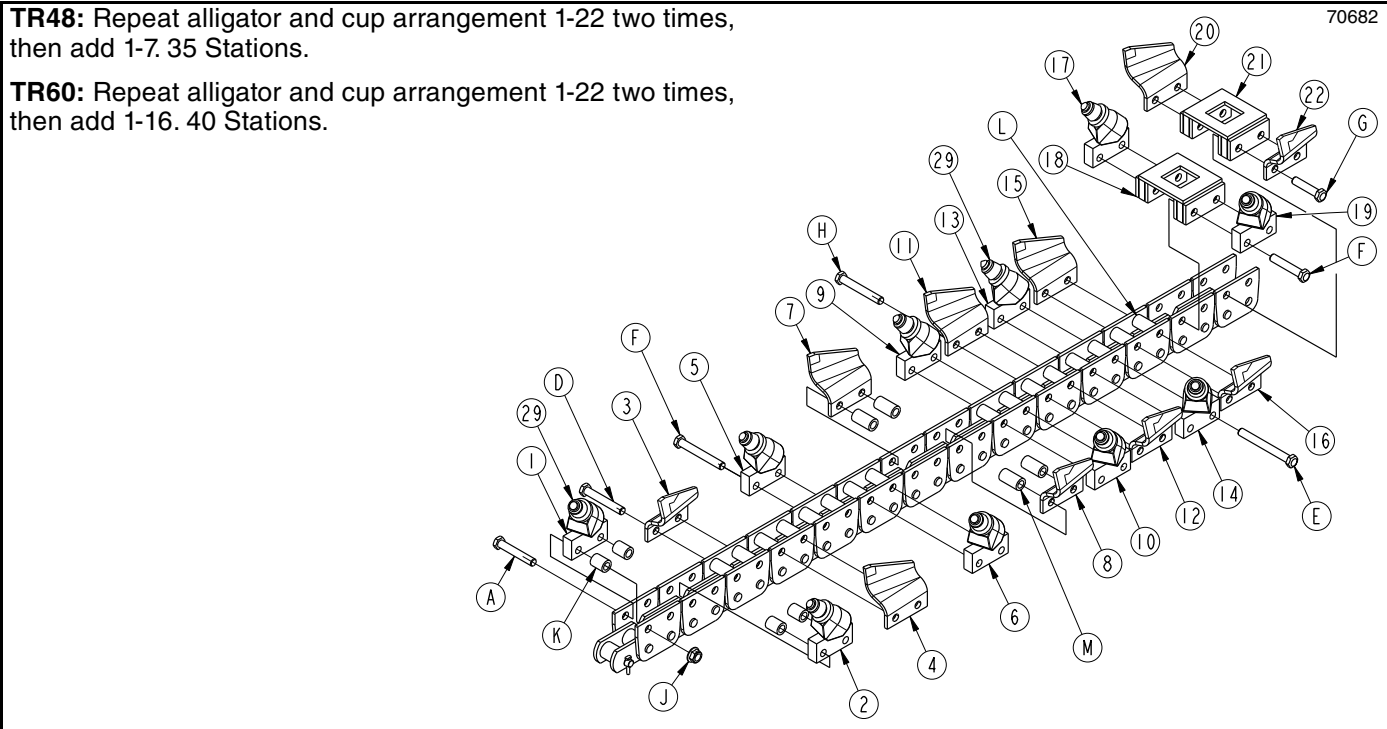

8" Alligator and Cup Teeth With 2 Pitch Spacing
Figure 4-10

TR48: Repeat alligator and cup arrangement 1-28 two times, then add 1-3. 35 Stations.

TR60: Repeat alligator and cup arrangement 1-28 two times, then add 1-8. 40 Stations.

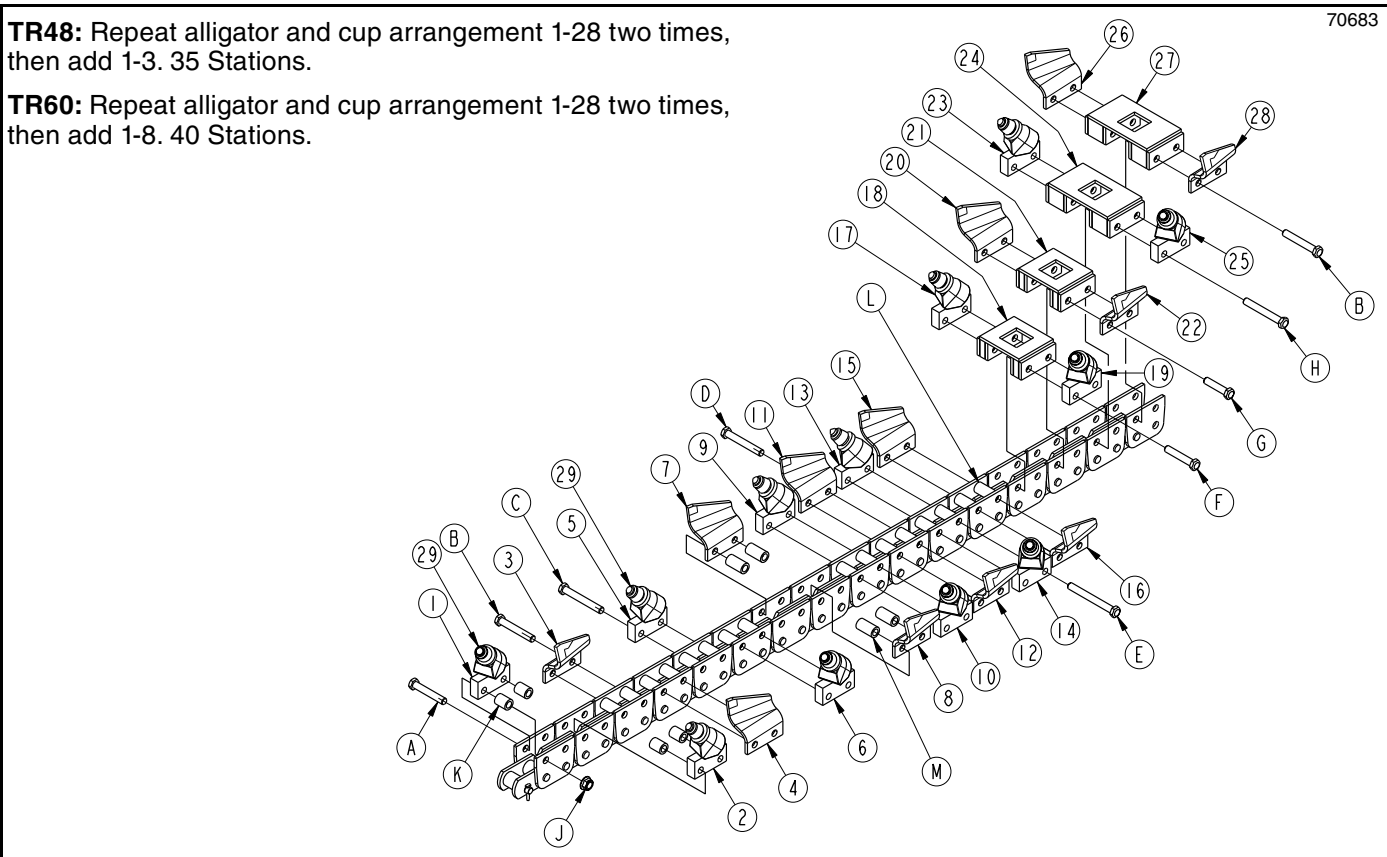

10" Alligator and Cup Teeth With 2 Pitch Spacing
Figure 4-11

Scorpion and Cup Teeth

Refer to Figure 4-12, Figure 4-13, & Figure 4-14:

Part numbers listed below are for complete chain assemblies. Purchase individual teeth and attaching hardware through your local Kubota dealer.

Part No. TR48 Scorpion and Cup Teeth

- 350-177A 6" (15 cm) Scorpion & cup teeth w/ 2 pitch spacing
- 350-178A 8" (20 cm) Scorpion & cup teeth w/ 2 pitch spacing
- 350-179A 10" (25 cm) Scorpion & cup teeth w/ 2 pitch spacing

Part No. TR60 Scorpion and Cup Teeth

- 350-193A 6" (15 cm) Scorpion & cup teeth w/ 2 pitch spacing
- 350-196A 8" (20 cm) Scorpion & cup teeth w/ 2 pitch spacing
- 350-197A 10" (25 cm) Scorpion & cup teeth w/ 2 pitch spacing

Part No. Description of Fasteners

- A 842-393C Hex head cap screw 1/2-20X3 GR8 PLT
- B 842-394C Hex head cap screw 1/2-20X3 1/4 GR8 PLT
- C 842-438C Hex head cap screw 1/2-20X3 3/4 GR8 PLT
- D 842-395C Hex head cap screw 1/2-20X3 1/2 GR8 PLT
- E 842-439C Hex head cap screw 1/2-20X4 1/2 GR8 PLT
- F 842-392C Hex head cap screw 1/2-20X2 3/4 GR8 PLT
- G 842-391C Hex head cap screw 1/2-20X2 1/4 GR8 PLT
- H 842-438C Hex head cap screw 1/2-20X3 3/4 GR8 PLT
- J 803-308C Nut hex flange lock 1/2-20 PLT GR G
- K 350-445D Spacer inside 1.05"LG
- L 350-262D Spacer inside long 1.80"LG
- M 350-250D Spacer inside long 1.55"LG

Part No. Description of Teeth

- 1 820-642C Scorpion LH bolt on CNT-4" (Stamped #37)
- 2 820-643C Scorpion RH bolt on CNT-4" (Stamped #36)
- 3 820-623C Cup tooth LH
- 4 820-624C Cup tooth RH
- 5 820-643C Scorpion RH bolt on CNT-4" (Stamped #36)
- 6 820-642C Scorpion LH bolt on CNT-4" (Stamped #37)
- 7 820-624C Cup tooth RH
- 8 820-623C Cup tooth LH
- 9 820-651C Scorpion RH 5" bolt on (Stamped #39)
- 10 820-650C Scorpion LH 5" bolt on (Stamped #38)
- 11 820-624C Cup tooth RH
- 12 820-623C Cup tooth LH
- 13 820-640C Scorpion RH 6" bolt on (Stamped #40)
- 14 820-641C Scorpion LH 6" bolt on (Stamped #41)
- 15 820-624C Cup tooth RH
- 16 820-623C Cup tooth LH
- 17 820-651C Scorpion RH 5" bolt on (Stamped #39)
- 18 350-215H Spreader 8"
- 19 820-650C Scorpion LH 5" bolt on (Stamped #38)
- 20 820-624C Cup tooth RH
- 21 350-215H Spreader 8"
- 22 820-623C Cup tooth LH
- 23 820-651C Scorpion RH 5" bolt on (Stamped #39)
- 24 350-227H Spreader 10"
- 25 820-650C Scorpion LH 5" bolt on (Stamped #38)
- 26 820-624C Cup tooth RH
- 27 350-227H Spreader 10"
- 28 820-623C Cup tooth LH

TR48: Repeat scorpion and cup arrangement 1-16 two times, then add 1-14. 35 Stations.

TR60: Repeat scorpion and cup arrangement 1-16 three times, then add 1-4. 40 Stations.

70690

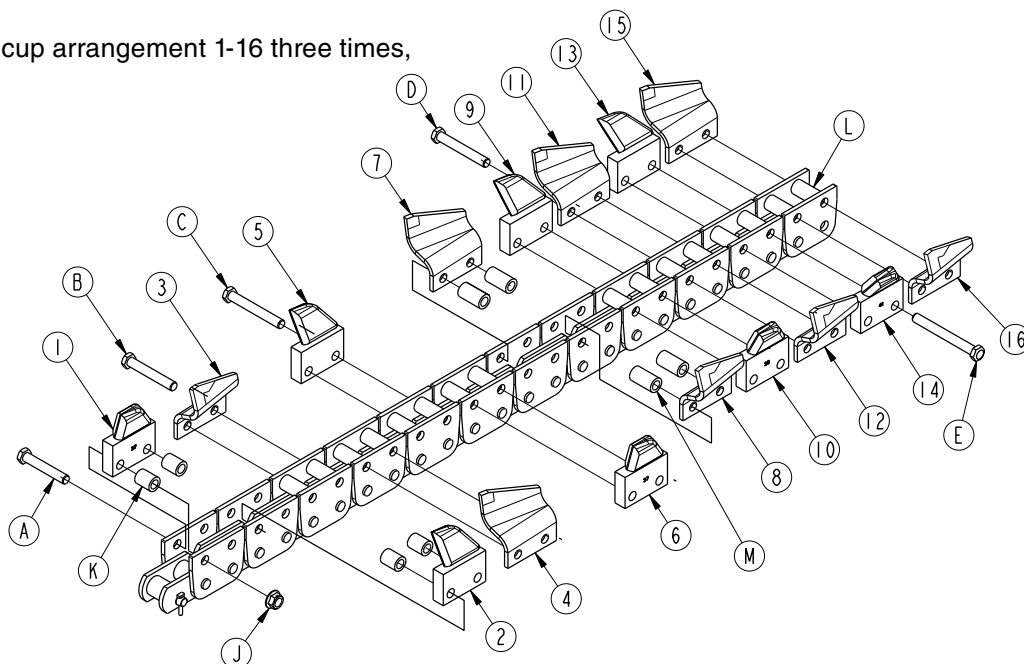

6" Scorpion and Cup Teeth With 2 Pitch Spacing
Figure 4-12

Section 4: Options

TR48: Repeat scorpion and cup arrangement 1-22 two times, then add 1-7. 35 Stations.

TR60: Repeat scorpion and cup arrangement 1-22 two times, then add 1-16. 40 Stations.

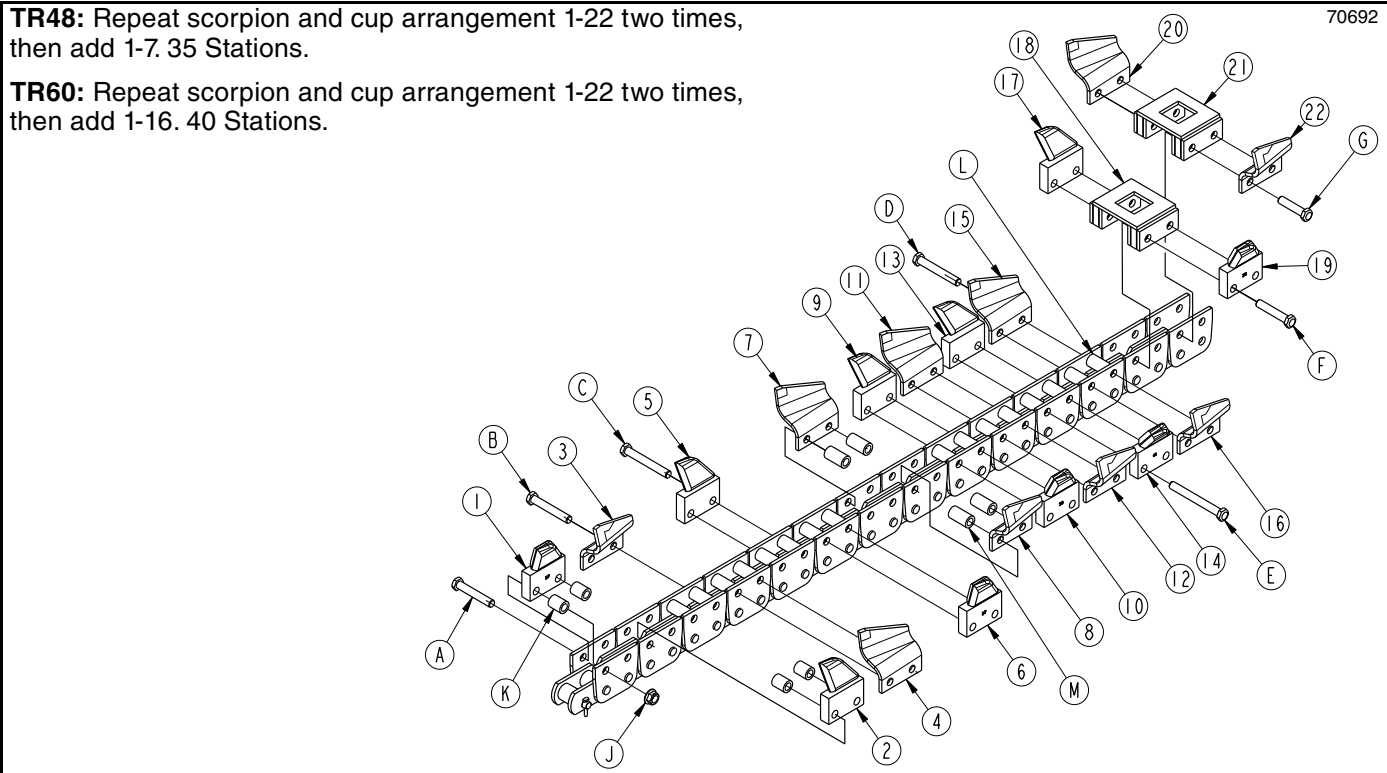

8" Scorpion and Cup Teeth With 2 Pitch Spacing
Figure 4-13

TR48: Repeat scorpion and cup arrangement 1-28 two times, then add 1-3. 35 Stations.

TR60: Repeat scorpion and cup arrangement 1-28 two times, then add 1-8. 40 Stations.

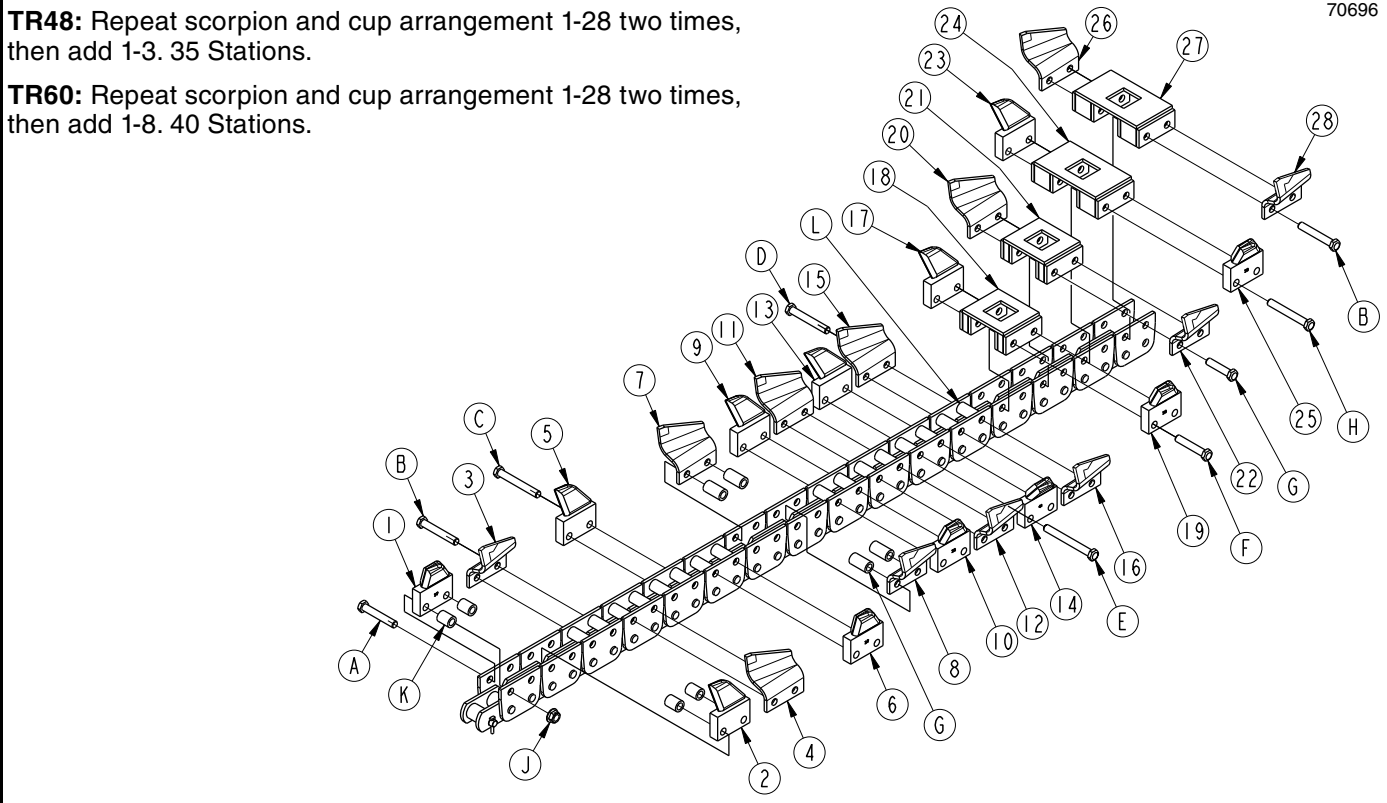

10" Scorpion and Cup Teeth With 2 Pitch Spacing
Figure 4-14

Section 5: Maintenance & Lubrication

Maintenance

Proper servicing and adjustment are key to the long life of any attachment. With careful and systematic inspection, you can avoid costly maintenance, time, and repair.

After using your trencher for several hours, check all bolts to be sure they are tight. Especially check the chain bolts for tightness.

Replace any worn, damaged, or illegible safety labels by obtaining new labels from your Kubota dealer.

DANGER

To avoid serious injury or death:

- Do not go near or under raised loader arms without first securing loader arms in the raised position with an approved lift-arm support.
- Keep bystanders 20 feet (6 meters) away from the rotating chain and auger to avoid entanglement in them.
- Always secure equipment with solid, non-concrete supports before working under it. Never go under equipment supported by concrete blocks or hydraulics. Concrete can break, hydraulic lines can burst, and/or hydraulic controls can be actuated even when power to the hydraulics is off.

WARNING

To avoid serious injury or death:

- Make sure controls are all in the neutral position or park before starting the power machine.
- Always shut power machine down using the “Shutdown Procedure” provided in this manual before servicing, adjusting, cleaning, or maintaining the attachment.
- Keep body, body extremities, loose clothing, pull strings, etc. away from pinch points such as rotating, extending, and/or retracting components. Secure pinch point areas to ensure they will not move before working on or near them.
- Perform scheduled maintenance. Check for loose hardware, missing parts, broken parts, structural cracks, and excessive wear. Make repairs before putting the implement back into service.
- Do not alter attachment or replace parts on the attachment with other brands. Other brands may not fit properly or meet OEM (Original Equipment Manufacturer) specifications. They can weaken the integrity and impair the safety, function, performance, and life of the attachment. Replace parts only with genuine OEM parts.

General Inspection

Inspect trencher daily before putting it into service.

1. Check hitch fit up. Make certain loader hitch is fully seated under the top angle bar, lock handles are locked down, and lock pins are fully seated in the bottom slots.
2. Check for loose hardware and fittings. Tighten any loose hardware and fittings.
3. Check condition of safety shields. Replace damaged or missing shields.
4. Check hoses and fittings for oil leaks, stretching, and pinching. Repair all oil leaks and adjust hoses to avoid stretching and pinching.
5. Check chain tension. Refer to “**Check Chain Tension**” on page 38.
6. Check sprocket, chain, and teeth for wear and loose teeth. Tighten loose teeth and replace worn components.
7. Check backup alarm and review mirror on skid steer. Repair backup alarm if it is not in good working condition. Adjust rear-view mirror to get the best view behind the skid steer. Replace missing or broken rear-view mirrors.

Chain Service in Harsh Conditions

Shut down trencher every 2-3 hours of use when trenching in rocky or frozen conditions and physically check the chain’s nuts, bolts, teeth, and tension.

- Check for lose, bent, and missing bolts and nuts. Although nuts are locking, they can become loose when used in harsh conditions. Loctite Threadlocker 242 can be applied to the bolt threads to help stop the nuts from coming loose. Tighten loose nuts and replace bent, broken, or missing bolts.
- Check for loose, broken, or missing teeth. Tighten loose teeth. Replace broken and missing teeth.
- Check chain tension. Add grease to the chain tensioner as needed to keep the chain properly tensioned when working harsh conditions.

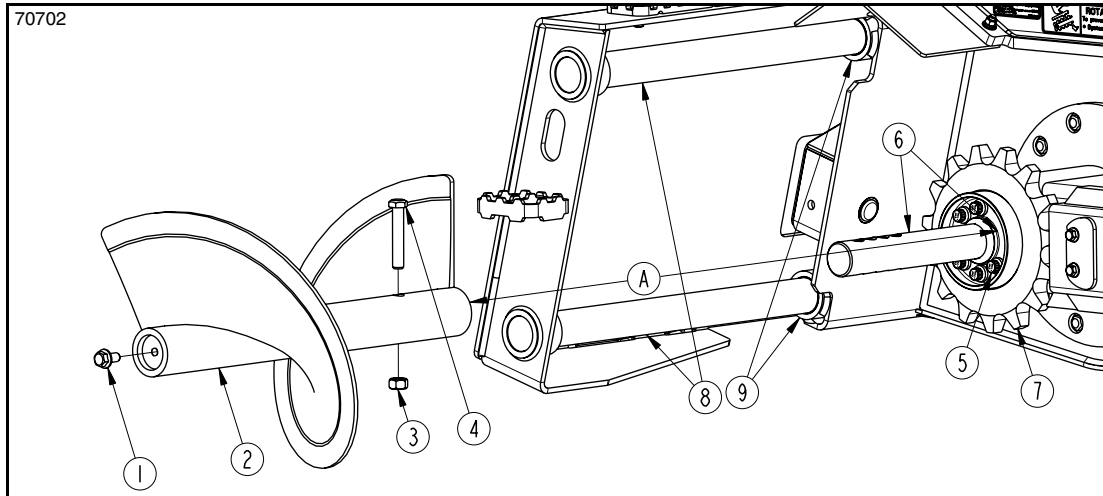

Auger Maintenance
Two Special 12 Point Flange Head Bolt 5/8-11 Removed for Clarity
Figure 5-1

Auger Removal

Refer to Figure 5-1:

| Part No. | Description |
|----------|--------------------------------|
| 350-362H | Auger 15 1/2" (39 cm) diameter |

Dirt deposited next to the trench can fall back into the trench. Replace worn auger (#1) when it starts leaving too much dirt close to the trench.

NOTE: If auger does not move, remove bolt (#5) and install a puller to loosen the auger. The puller consists of a 1/2"-13 x 20" long all thread rod with a nut welded to one end. Insert threaded rod into the threaded bolt hole until auger is removed. Use nut to turn threaded rod.

1. Remove nut (#3), bolt (#4), and auger (#2).
2. If replacing chain and sprocket, continue with **“Chain Removal and Replacement”** on page 38. Otherwise, continue with **“Auger Installation”**.

Auger Installation

Refer to Figure 5-1:

1. Install anti-seize to auger shaft (#6).
2. Install new or existing auger (#2) onto shaft (#6).
3. Measure distance (A) from **end of auger tube (#2)** to the **inside face** of auger shaft mount (#6). Nominal distance (A) should be as follows:
 - 6" (15 cm) chain width: A = 1 1/2" (4 cm)
 - 8" (20 cm) chain width: A = 2 1/2" (6 cm)
 - 10" (25 cm) chain width: A = 3 1/2" (9 cm)
4. Slide auger (#2) to the correct distance (A).
5. Replace bolt (#4) and secure with hex nut (#3). Tighten hex nut to the correct torque for a 5/8"-11 GR5 bolt.
6. If removed, install hex flange bolt (#1) and tighten to the correct torque for a 1/2"-13 GR8 bolt.

Side Shift Bars

Refer to Figure 5-1:

It is good practice to always clean and apply a fresh coat of dry lubricant to the side shift rods before side shifting the trencher and when storing it for long periods.

1. Shut skid steer down using **“Skid Steer/Track Loader Shutdown Procedure”** on page 16 before dismounting the skid steer to clean the side shift bars.

IMPORTANT: Do not use a wet lubricant such as oil or grease. Wet lubricants collect dirt and cause the side shift mechanism to not work properly.

IMPORTANT: Always clean the side shift rods of all dirt and coat the rods with dry lubricant before side shifting the trencher.

2. Clean side shift rods (#8) of all dirt and foreign particles. Make sure you do this on each side of the drive mounts (#9).
3. Lubricate all exposed surfaces of the shift rods (#8) with dry lubricant.

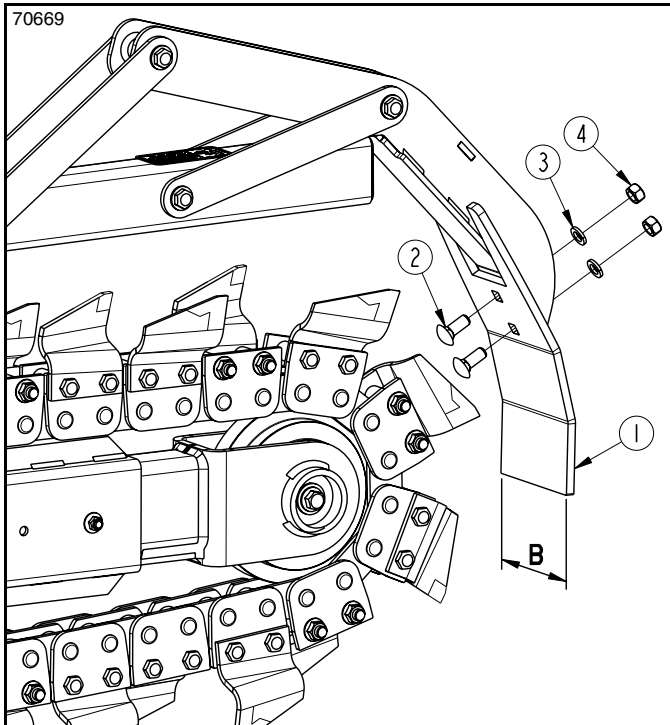

Crumber Shoe Maintenance
Figure 5-2

Crumber Shoe Maintenance

Refer to Figure 5-2:

Inspect crumber shoe (#1) for wear, structural cracks, and deformity. If needed, replace crumber shoe with a new shoe. When changing the trencher chain to a different width, replace crumber shoe to match the new chain width. See “**Crumber Shoe Option**” on page 26 for part numbers.

1. Remove nuts (#4), lock washers (#3), carriage bolts (#2), and crumber shoe (#1).
2. Install correctly sized crumber shoe (#1) with existing carriage bolts (#2), lock washers (#3) and hex nuts (#4). Tighten hex nuts to the correct torque for a 1/2"-13 GR5 bolt.

Check Chain Tension

Check chain tension daily. It is very important to keep the chain properly tensioned. The trencher will operate more efficiently and experience less wear.

Loose chains tend to accumulate in the drive sprocket and bounce around on the top and bottom chain guides. They can require more horsepower and create unnecessary wear on drive components and chain guide rails. In severe situations; the chain will jump off the drive sprocket.

Tight chains add stress and wear to the chain, drive sprocket, end roller, shafts, bearings, and boom causing increased horsepower consumption and shorter component life.

Check Chain and Sprocket Wear

Check chain and sprockets daily for wear, loose components, and missing components. Make a thorough check at the end of each job before moving on to the next job. An improperly maintained component affects how the trencher operates.

The chain pitch length increases as the chain pins and rollers wear. Replace the chain if there is a worn groove in the middle of the roller. A worn chain will not wrap the sprocket correctly. The first sprocket tooth engaging with the chain carries the load. The other teeth lose engagement due to increased pitch length. This increased load on an individual sprocket tooth causing accelerated sprocket wear.

Check sprocket teeth for wear. A worn chain usually causes sprocket tooth wear. Do not run a new chain on a worn sprocket or a worn chain on a new sprocket. The worn component will cause accelerated wear on the new component. To get the most life out of both components, replace chain and sprocket together.

Chain Removal and Replacement

WARNING

To avoid serious injury or death:

Lube fittings for the chain tensioner may be under high pressure. Wear proper protective equipment and stand to one side of the fittings when zerk and bleeder screw are exposed. Keep bystanders on the opposite side of the boom. Always use correct fittings when replacing the zerk or bleeder screw.

Prep for Chain Removal

Refer to Figure 5-3:

1. With trencher attached, park skid steer on solid, level ground in an open area where you have 10 ft. to back the skid steer up.
2. Lower trencher fully down and rotate top of hitch plate back to lift chain off the ground.
3. Shutdown skid steer using “**Skid Steer/Track Loader Shutdown Procedure**” on page 16.

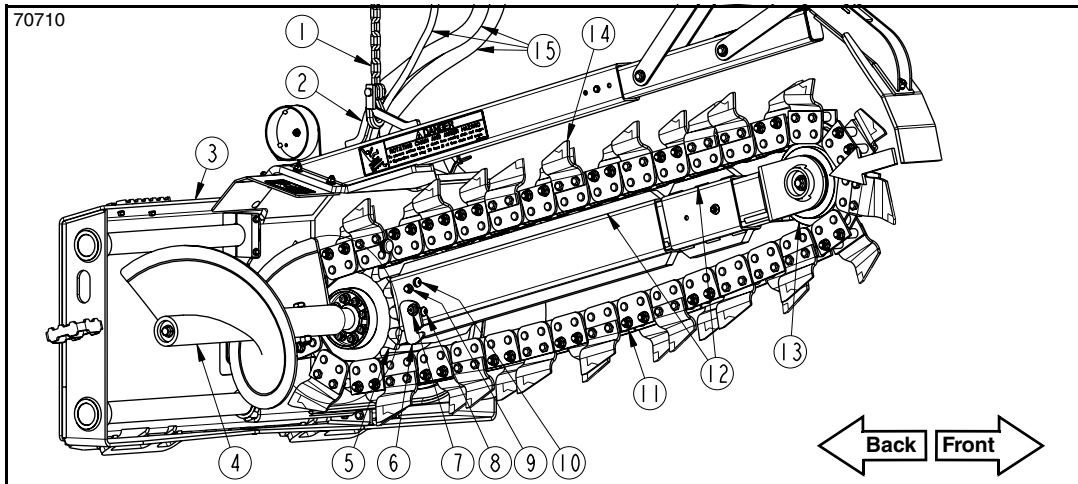

Chain replacement (Continuous Loop)
Figure 5-3

4. With a hoist, attach lift chain (#1) to lift point (#2). Draw lift chain up snug to secure the trencher boom in this position.
5. While standing to one side of cover (#6), loosen bottom bolt (#7). Loosen top bolt (#9) and rotate cover (#6) down.
6. If available, attach a 1/4" poly hose to bleeder screw (#8). Place opposite end of hose in a container to catch excess grease.
7. Make sure you are not standing in line with bleeder screw (#8). Loosen bleeder screw (not more than 1/2 turn) until grease starts to flow out the screw.
8. Push tensioner cylinder back by pushing on chain roller (#13) until chain (#11) becomes slack.
9. If replacing sprocket (#5), remove auger (#4) before removing chain (#11). Refer to “**Auger Removal**” on page 37.
10. The customer can choose to remove the chain as a continuous loop or break the chain apart at the master coupler and remove as a single chain strand.
 - Remove as a continuous loop: Refer to “**Remove & Install Continuous Chain Loop**” on page 39.
 - Remove as a chain strand: Refer to “**Remove & Install Single Chain Strand**” on page 40

Remove & Install Continuous Chain Loop

Refer to Figure 5-3 on page 39:

Chain Removal:

1. Complete “**Prep for Chain Removal**” on page 38.
2. Disconnect hydraulic hoses (#15) from the skid steer.
3. Lift chain (#11) off end of roller (#13). Lay that end on the ground.
4. Lift chain (#11) off sprocket (#5) and if needed, over auger (#4).
5. Move chain (#11) to storage or work area.
6. If replacing sprocket (#5), refer to “**Sprocket Replacement**” on page 41. If installing a new chain, continue with “**Chain Installation**” on this page.

Chain Installation

1. Complete “**Prep for Chain Removal**” on page 38.
2. Disconnect hydraulic hoses (#15) from the skid steer.

IMPORTANT: Chain teeth must point forward on the upper guide rail for the trencher to operate properly.

3. With teeth (#14) pointing forward on upper guide rail (#12), slide new or reworked chain (#11) over auger (#4) and onto sprocket (#5).
4. Place chain (#11) on the top guide rails (#12) with teeth (#14) pointing forward.
5. Place chain (#11) over roller (#13).
6. Tension chain to the correct torque. Refer to “**Adjust Chain Tension**” on page 19.
7. If removed, install auger (#4). Refer to “**Auger Installation**” on page 37.

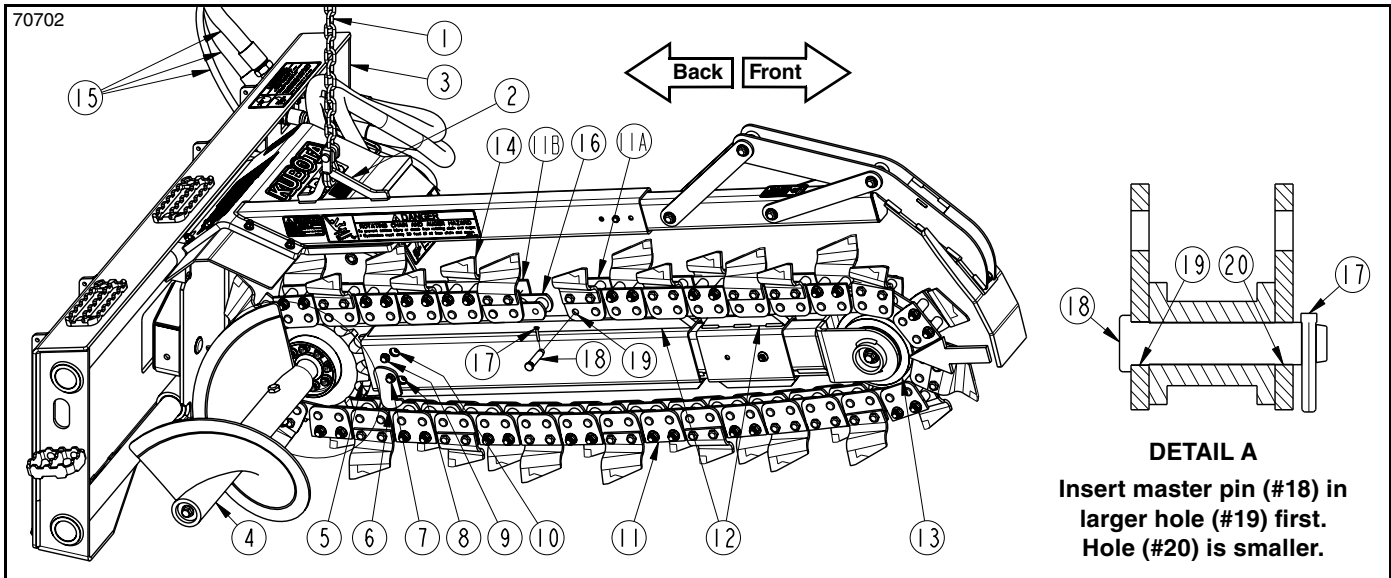

Chain replacement (Single Strand)
Figure 5-4

Remove & Install Single Chain Strand

Refer to Figure 5-4:

Chain Removal

1. Complete “Prep for Chain Removal” on page 38.
2. Locate coupler (#16) with master pins (#18) and keeper pins (#17). Mark this chain coupler to make it easy to find.
3. Return to the skid steer and rotate trencher chain until marked chain coupler (#16) is on top and near roller (#13).
4. Shutdown skid steer using “**Skid Steer/Track Loader Shutdown Procedure**” on page 16.
5. The head end of master pin (#18) press fits into hole (#19). Back-up opposite side of coupler with a heavy hammer and drive pin (#18) out.
6. Lift front chain (#11A) off upper chain guide rails (#12) and front chain roller (#13). Lay front chain half on the ground.
7. Return to the skid steer seat. Reverse chain while backing up to rotate chain (#11B) around sprocket (#5) and onto the ground.
8. Move chain (#11) to storage or work area.
9. If replacing sprocket (#5), refer to “**Sprocket Replacement**” on this page. If installing a new chain, continue with “**Chain Installation**” on this page.

Chain Installation

1. Complete “Prep for Chain Removal” on page 38.
2. Lay chain straight out in line with trencher boom with teeth pointing down and toward the boom.
3. Pull skid steer forward until chain (#11B) is under sprocket (#5).

4. Shutdown skid steer using “**Skid Steer/Track Loader Shutdown Procedure**” on page 16.
5. Wrap back portion of chain (#11B) over sprocket (#5).

IMPORTANT: Chain teeth must point forward on the upper guide rail for the trencher to operate properly.

6. Make sure chain teeth (#14) point forward as shown on upper guide rail (#12).
7. Run hydraulic motor to drive chain forward half way on upper guide rail.
8. Shutdown skid steer using “**Skid Steer/Track Loader Shutdown Procedure**” on page 16.
9. Disconnect hydraulic hoses (#15) from the skid steer.
10. Wrap front portion of chain (#11A) around roller (#13) and up onto upper guide rails (#12).
11. Locate pinhole (#19) in station (#11A). This hole will be larger than the hole on the far side of the station.
12. Pull chain station (#11A) to master coupler (#11B) until pin holes in master coupler align with holes in station (#11A).

NOTE: See Detail A: Master pin (#18) has a larger step diameter at its head. Insert master pin in the larger hole (#19). Hole (#20) is smaller.

13. Drive master pin (#18) in the larger hole (#19) until pin head is flush with the chain link.
14. Insert keeper pin (#17) in master pin (#18) and bend the shank enough to prevent the keeper pin from falling out.
15. If removed, install auger (#4). Refer to “**Auger Installation**” on page 37.

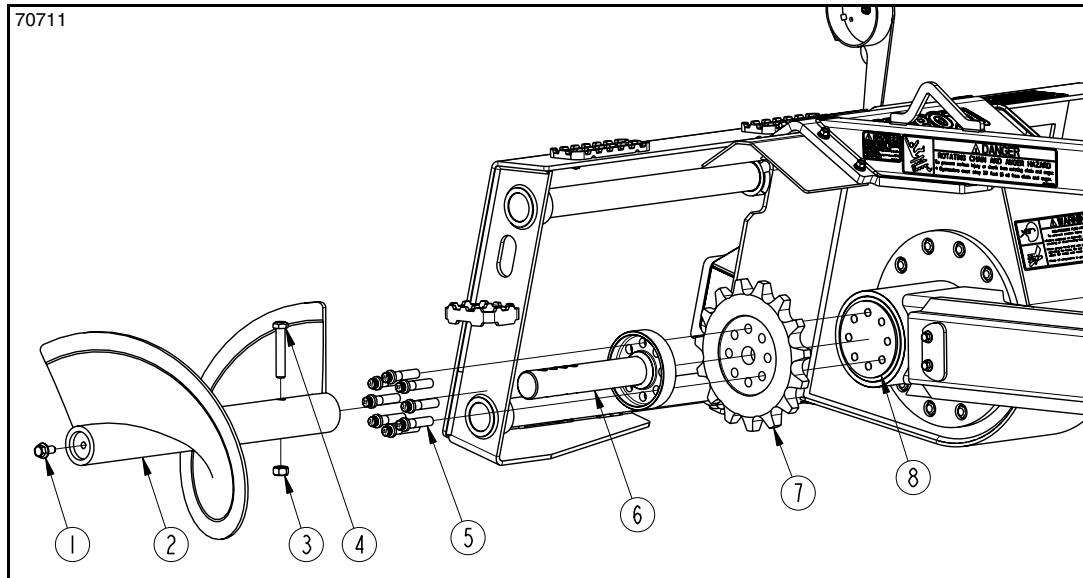

Sprocket Replacement
Figure 5-5

Sprocket Replacement

Refer to Figure 5-5:

1. If replacing chain and sprocket, Refer to “**Chain Removal and Replacement**” on page 38.
2. If replacing sprocket only, remove nut (#3), bolt (#4), and auger (#2).

NOTE: If auger does not move, remove bolt (#5) and install a puller to loosen the auger. The puller consists of a 1/2"-13 x 20" long all thread rod with a nut welded to one end. Insert threaded rod into the threaded bolt hole until auger is removed. Use nut to turn threaded rod.

3. Remove special 12 point flange bolts (#5), auger shaft (#6), and sprocket (#7).
4. Attach new sprocket (#7) and auger shaft (#6) to shaft drive (#8) with special 12 point flange bolts (#5). Torque bolts (#5) to the correct torque value using “**Additional Torque Values**” on page 51.
5. Install new or existing chain. Refer to “**Chain Removal and Replacement**” on page 38.

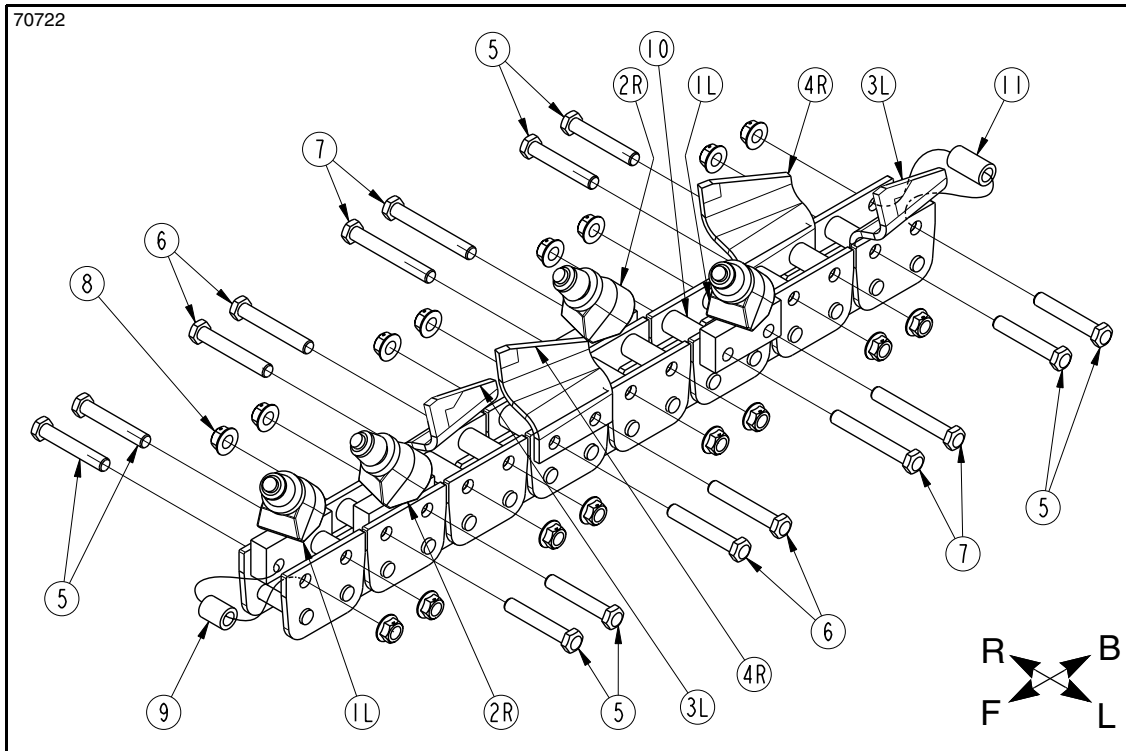

Tooth Replacement
Figure 5-6

General Tooth Maintenance

Check for loose teeth daily. Loose teeth cause damaged chain components. Tighten nuts (#8) to tighten up a tooth. If the tooth does not tighten, check for bent bolts and damaged threads. Replace damaged bolts and nuts with new bolts and nuts. Loctite Threadlocker 242 can be applied to the bolt threads to help secure the nuts,

Refer to Figure 5-6:

Chain teeth do not wear equally. Some will become dull ahead of others leaving the sharp teeth to do the work. To maintain peak performance, always check for and replace dull teeth when the trencher acts sluggish.

When replacing teeth, be sure to replace the original tooth with an identical tooth and to attach the new tooth to the chain arranged identically as the original tooth. Not always is a right-hand tooth placed on the right side of the chain or a left-hand tooth placed on the left side of the chain. For example:

- The LH alligator tooth (#1L) is on the right side of the chain and farther back on the left side.
- The LH cup tooth (#3L) is on the right side of the chain and farther back on the left side.
- For detailed chain and tooth profile, see “**Trencher Chain Selection Options**” on page 26.

Bolt lengths vary depending on whether the digging teeth are mounted inside the chain links or outside the chain links, on one side of the chain link or on both sides of the chain link, and how thick the tooth is. For example:

- All teeth mounted inside the chain link are secured with two 3" long bolts (#5).
- A cup tooth mounted outside the chain is secured with two 3 1/4" long bolts (#6).
- An alligator tooth mounted outside the chain is secured with two 3 3/4" long bolts (#7).
- Other bolt lengths are also used depending on the tooth configuration. For detailed tooth profile, see “**Trencher Chain Selection Options**” on page 26.

The bolts are secured with hex flange locknuts (#8). Tighten locknuts (#8) to the correct torque for 1/2"-20 GR8 bolts. If teeth are loose after torquing the nuts, check for and replace any bolt or nut that is bent or thread damaged. Apply Loctite Threadlocker 242 to the bolts to help stop the nuts from coming loose.

Bushing (#9, #10, & #11) vary in length depending on the tooth arrangement. Be sure to purchase the correct bushing when replacing it. For detailed tooth profile, see “**Trencher Chain Selection Options**” on page 26.

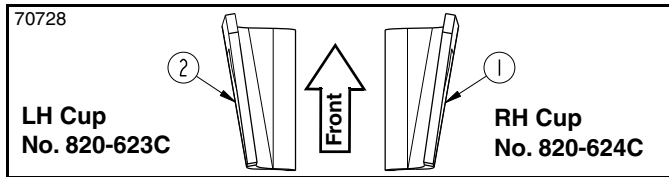

Cup Teeth (Top View)
Figure 5-7

Cup Teeth

Refer to Figure 5-7:

Check for and replace missing or damaged cup teeth. There are only two different cup teeth (#1 & #2). Identify right- and left-hand cups by viewing them from the top with their points facing forward. See Figure 5-7 for cup part numbers.

Alligator Teeth

Refer to Figure 5-8:

Check for and replace missing or damaged bit holders. See Figure 5-8 for bit holder part numbers. Identify left- and right-hand bit holders by viewing them from the top with bit (#1) facing forward.

Bit holders angling 15° to the right are stamped #6.

Bit holders angling 15° to the left are stamped #7.

Bit holders angling 25° to the right are stamped #9.

Bit holders angling 25° to the left are stamped #8.

Bit holders angling 40° to the right are stamped #0.

Bit holders angling 40° to the left are stamped #1.

Refer to Figure 5-9:

Tips (#1) are not included with bit holders (#4).

Tip part number is 820-652C.

Check bits (#1) on the alligator chain. Replace any that are dull or missing. Drive old bits out with a punch (#5) and hammer. Place punch in the bottom hole of the bit holder (#4) and tap bit out of the holder. Make sure the bit clip (#3) did not remain in the holder.

Replace new bit (#1) with clip (#3) in bit holder (#4).

Place punch (#5) on the top side of flange (#2) and tap bit in until the flange is against face of bit holder (#4). Bit (#1) should rotate freely in bit holder (#4).

Scorpion Teeth

Refer to Figure 5-10:

Check for and replace missing or damaged scorpion teeth. Identify scorpion teeth by the number stamped on the side. See Figure 5-10 for scorpion part numbers. If stamped number is missing, identify scorpion tooth by its angle and direction of tilt when viewed from the rear.

Teeth angling 20° to the right are stamped #36.

Teeth angling 20° to the left are stamped #37.

Teeth angling 30° to the right are stamped #39.

Teeth angling 30° to the left are stamped #38.

Teeth angling 40° to the right are stamped #40.

Teeth angling 40° to the left are stamped #41.

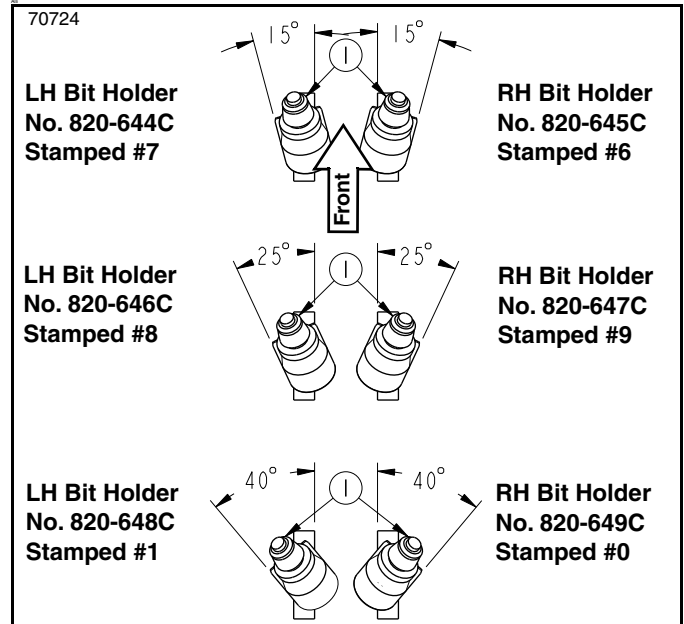

Bit Holder (#4) Shown with bits (#1) (Top View)
Figure 5-8

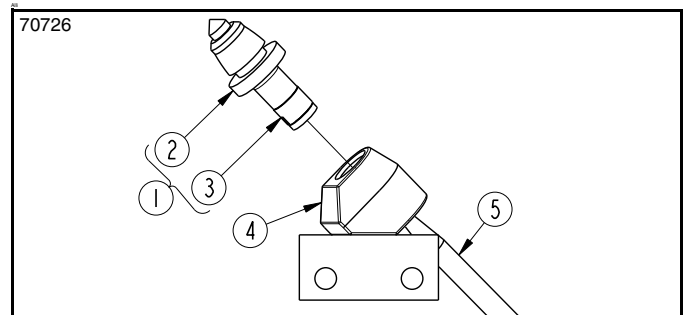

Alligator bit Replacement
Figure 5-9

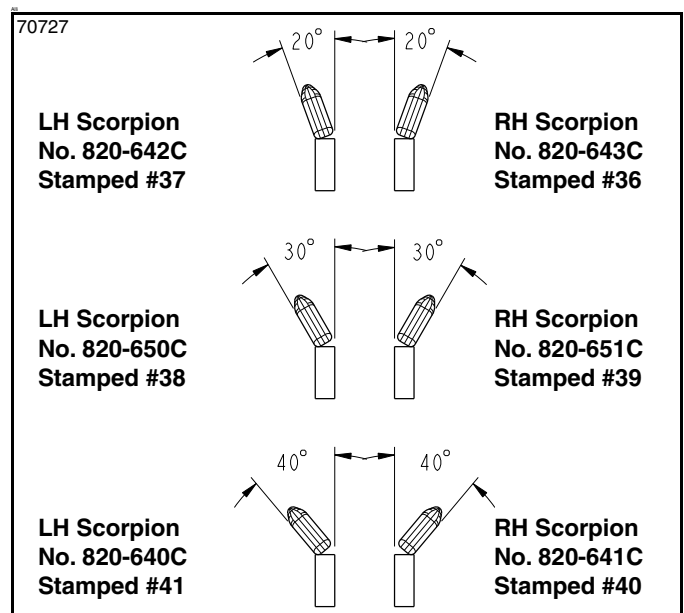

Scorpion Teeth (Rear View)
Figure 5-10

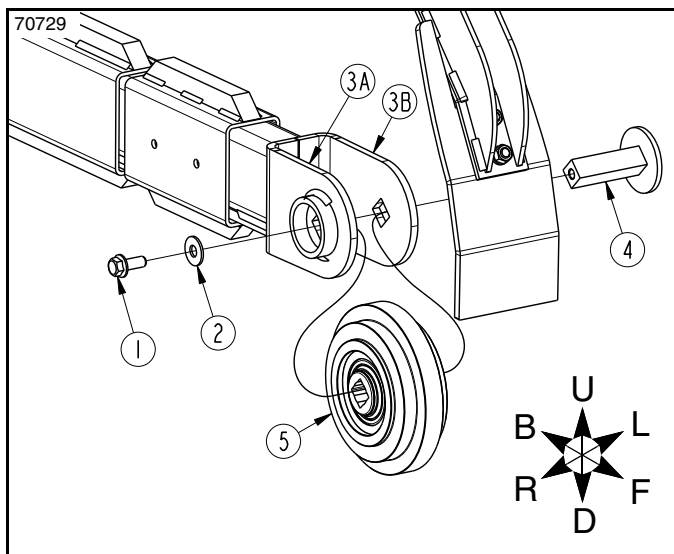

Remove Front Roller
Figure 5-11

Remove & Install Front Roller

Refer to Figure 5-11:

Remove Front Roller

1. Remove chain or break chain at the coupler to remove chain from the roller. Refer to “**Chain Removal and Replacement**” on page 38.
2. Remove hex flange serrated bolt (#1), flat washer (#2), roller shaft (#4), and roller (#5).
3. Keep all components for replacement.

Install Front Roller

1. Insert new or existing roller (#5) between clevis plates (#3A & #3B).
2. On the left side of roller (#5), align the bearing’s square hole with hole in clevis plate (#3B).
3. Insert roller shaft (#4) on the left side as shown.
4. Rotate square hole in the right side bearing to align with square hole in clevis plate (#3A).
5. Continue to push roller shaft (#4) through the roller and into clevis plate (#3A) until the shaft is fully inserted.
6. Secure roller shaft (#4) with flat washer (#2) and hex flange serrated bolt (#1). Tighten bolt (#1) to the correct torque for a 1/2"-13 GR5 bolt.
7. Replace chain over the front roller (#5). Refer to “**Chain Removal and Replacement**” on page 38.

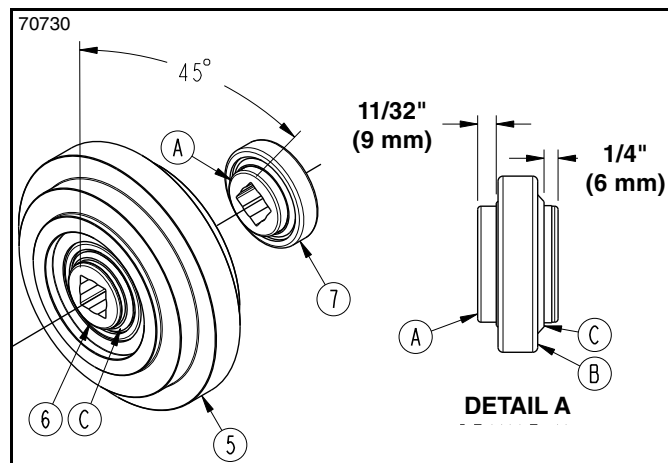

Replace Bearings in Roller
Figure 5-12

Replace Bearings in Front Roller

Refer to Figure 5-12:

Remove Old Bearings From Front Roller

1. Remove front roller (#5) from the trencher. Refer to “**Remove Front Roller**” on this page.
2. Rotate inner square race of rear bearing (#7) 45° past inner square race of front bearing (#6) as shown.
3. Insert roller shaft (#4) shown in Figure 5-11 through bearing (#6) until against bearing (#7).
4. Press against inner race (A) of bearing (#7) until the bearing is removed from roller (#5).
5. Turn roller (#5) around, and press against inner race (A) of bearing (#6) until bearing is removed from the roller.
6. Discard bearings (#6 & #7).

Install New Bearings in Front Roller

IMPORTANT: Do not press against inner race (A) when installing bearings. Doing this will damage the bearings.

IMPORTANT: Bearings must be installed with the heavy seal (C) side facing out.

1. See Detail A: Insert 11/32" offset side of bearing (#6) into roller (#5). Heavy seal (C) must face out.
2. Press against outer race (B) until bearing (#6) is against the stepped offset located inside roller (#5).
1. See Detail A: Turn roller (#5) around and insert 11/32" offset side of bearing (#7) into the roller. Heavy seal (C) must face out.
2. Press against outer race (B) until bearing (#7) is against the stepped offset located inside roller (#5).
3. Attach roller to clevis plates (#3A & #3B) shown in Figure 5-11. See “**Install Front Roller**” on this page.

Section 5: Maintenance & Lubrication

Long-Term Storage

Clean, inspect, service, and make necessary repairs to the attachment when storing it for long periods and at the end of the season. This will help to ensure the unit is ready for field use the next time you connect to it.

DANGER

To avoid serious injury or death:

Always secure equipment with solid, non-concrete supports before working under it. Never go under equipment supported by concrete blocks or hydraulics. Concrete can break, hydraulic lines can burst, and/or hydraulic controls can be actuated even when power to the hydraulics is off.

WARNING

To avoid serious injury or death:

- Always shut power machine down following the “Shutdown Procedure” provided in this manual before leaving the operator’s station.
- Do not alter attachment or replace parts on the attachment with other brands. Other brands may not fit properly or meet OEM (Original Equipment Manufacturer) specifications. They can weaken the integrity and impair the safety, function, performance, and life of the attachment. Replace parts only with genuine OEM parts.





1. Clean off any dirt and grease that may have accumulated on the attachment and moving parts. Scrape off compacted dirt from the roller and then wash surface thoroughly with a garden hose.

2. Inspect trencher for parts out of adjustment, loose, damaged or worn.
 - Make required adjustments.
 - Tighten all loose hardware.
 - Replace damaged and worn parts as needed.
3. Repaint worn or scratched parts to prevent rust. Ask your Kubota dealer for touch-up paint. Paint is available in aerosol can, quarts, and gallon sizes. See chart.

| Touch-Up Paint | |
|-----------------------|-----------------------------------|
| Part No. | Part Description |
| 821-070C | GLOSS BLACK ENAMEL SPRAY CAN |
| 821-070CTU | GLOSS BLACK ENAMEL BOTTLE & BRUSH |
| 821-070CQT | GLOSS BLACK ENAMEL QUART |
| 821-070CGL | GLOSS BLACK ENAMEL GALLON |

4. Replace all damaged or missing decals.
5. Lubricate as noted. Refer to “**Lubrication Points**” on this page.
6. Apply a light coat of dry lubrication to the side shift rods, rollers, and to any exposed hydraulic cylinder rods to minimize oxidation.
7. Store trencher on a level surface in a clean, dry place. Inside storage will reduce maintenance and make for a longer trencher life.

Lubrication Points

| | | | | |
|---------------------------|--|---|---|---|
| Lubrication Legend |  Multi-purpose spray lube |  Multi-purpose grease lube |  Multi-purpose oil lube |  50 Hrs Intervals in hours at which lubrication is required |
|---------------------------|--|---|---|---|

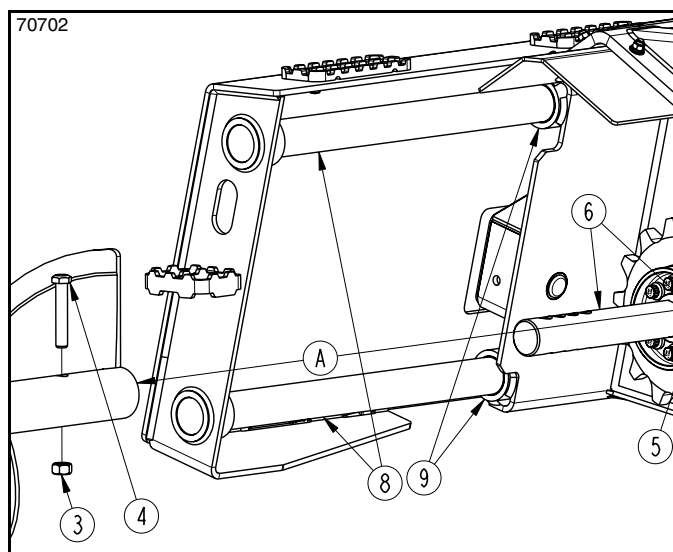

Side Shift Rods

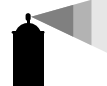
| | |
|---|--|
|  |  Before Side Shifting the Trencher |
|---|--|

Side Shift Rods

Preparation: Clean all dirt and debris off the side shift rods (#8). Do this on both sides of the drive mount (#9). Surfaces must be dry before applying dry lubrication.

Type of Lubrication: WD-40 special dry lubricant or equal.

Quantity: As needed

Frequency: Before side shifting the trencher and when storing trencher for long periods.

TR48 & TR60 Trencher

| Specifications & Capacities | | |
|--|--|--|
| Model Numbers | TR48 | TR60 |
| Operating weight With 2 pitch cup chain and hydraulic side shift. | 1236 lbs (560.6 kg) | 1282 lbs (581.5 kg) |
| Overall length | 90.5" (2.30 m) | 102.5" (2.60 m) |
| Standard boom length | 65.5" (1.66 m) | 77.5" (1.97 m) |
| Digging depth at 60 degrees | 4 ft (1.22 m) | 5 ft (1.52 m) |
| Frame width w/step | 61.13" (1.55 m) | |
| Overall width | 64" (1.63 m) | |
| Overall height | 34.1" (86.6 cm) | |
| Auger diameter | 15.5" (39.4 cm) | |
| Auger clearance | 28.5" - 30.5" (72.4 cm - 77.5 cm) | |
| Side shift options | Manual | Side shifts from center to 22" (55.9 cm) right of center |
| | Hydraulic | Side shifts from center to 22" (55.9 cm) right of center |
| Side shift travel | 22" (55.9 cm) | |
| Trenching widths available | 6", 8" & 10" (15.2 cm, 20.3 cm, 25.4 cm) | |
| Motor options | Low flow (LF) and high flow (HF) motors | |
| Hydraulic motor flow requirements | Low flow | 12-24 gpm (45.4-90.8 lpm) |
| | High flow | 24-40 gpm (90.8-151.4 lpm) |
| Hydraulic motor pressure range | Low flow | 2400-4500 psi (16.55-31.03 MPa) |
| | High flow | 2000-3600 psi (13.79-24.82 MPa) |
| Chain speed (Depending on skid steer flow and pressure ratings) | Low flow | 227-366 fpm (69-112 m/min) |
| | High flow | 221-373 fpm (67-114 m/min) |
| Motor case drain | Standard | |
| Motor | Reversible | |
| Chain tightener | Grease Cylinder | |
| Crumber shoe | Floating | |
| Depth indicator (Patent-pending) | Standard (Viewable from operator seat) | |
| Roller guide bearings at boom head | Self-contained, ball bearings with triple-lip seals and metal shroud covers | |
| Drive bearings between motor and drive sprocket | Self-contained, single and double row ball bearings with extra heavy duty seals | |
| Spoil auger | Removable | |
| Hydraulic coupler options | Standard and large flat face, connect under pressure, couplers | |
| Chain options – numerous | Cup teeth on 2 or 4 pitch, scorpion w/cup teeth, or alligator w/cup teeth | |
| Step and step pads | Heavy-duty, cast steel | |
| Frame construction | Heavy duty 5/16" (8 mm) thick w/ 3/4" (19 mm) reinforced bar around three sides the bottom lock pin slots. | |
| Trencher chain | 2.00" (5.1 cm) Pitch. 50,000 lb (22679.6 kg) tensile strength | |
| Trencher chain side links | Anti-flex | |
| Cup teeth | Hardened with hard facing | |

70720

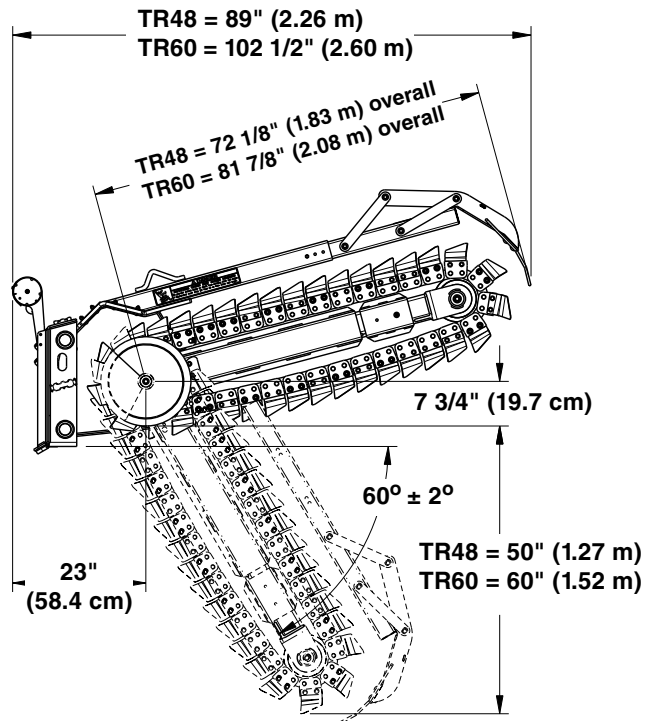
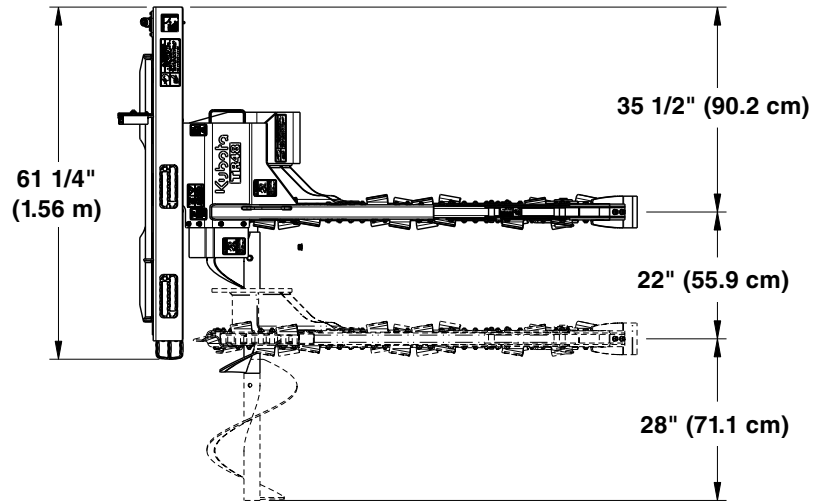

TR48 & TR60 Trencher

| Features | Benefits |
|--|--|
| Quality hydraulic motor available in two volume flows | Provides long life, durable construction. Two flow options allow the trencher to fit many skid steers. |
| Reversible motor | Helps in areas where rocks may lodge and stop chain, can back out and try again. |
| Boom ball bearings are self-contained ball bearing with triple-lip seals and metal shroud covers | Boom ball bearings are protected against dirt invasion and do not require greasing. |
| Drive bearings are self-contained, single and double row ball bearings with extra heavy duty seals. | Drive bearings are protected against dirt invasion and do not require greasing. |
| Motor case drain | Reduces back pressure at motor thus delivering more power for trenching. |
| Hardened cup teeth | Increase life and productivity of the teeth. |
| High tensile strength trencher chain | Chain stands up to rugged use. |
| Trencher chain side links | Designed for anti-flex without binding or piggybacking. |
| Full length bolts securing teeth with spacers at every station. | Helps to distribute load equally on both sides of the chain. Minimizes chain wear. |
| Side shifts from center to 22" to the right | Allows the operator to get up close to buildings and fences. |
| Grease cylinder chain tightener | Makes tightening the chain easy. |
| Connect under pressure hydraulic couplers | Couplers are easier to connect and disconnect. |
| Removable spoil auger | Helps dig a trench closer to fences and buildings |
| Floating crumber shoe | Improves the performance of the crumber shoe. |
| Depth indicator (Patent-pending) | Helps the operator judge the depth of trench from the operator's seat. |
| Numerous chain options | Plenty of options to choose from to match your local digging conditions. |
| Heavy frame construction | Stands up to rugged use. (5/16" Thick hitch plate with 3/4" reinforced bar around three sides of the bottom lock pin slots.) |
| TR48: 4' digging depth TR60: 5' digging depth | Customer can choose which trencher best suits his/her needs. |
| 221-373 fpm chain speed (Skid steer hydraulic flow and pressure ratings vary.) | Good operating speed to get the work done. |

Troubleshooting Chart

| Problem | Cause | Solution |
|---|--|--|
| Chain makes a clicking noise out of the ground. | Normal noise if head is turning with teeth out of the ground. | Normal |
| Chain makes a popping noise. | Clay and sand build-up on the sprocket teeth. Moisture conditions must be right. | Remove from dirt and reverse chain for 2 seconds to clean sprocket and then switch back to original direction. Repeat if needed. Continue digging. |
| Chain Hammers | Teeth are hitting rocky soil. | Check chain type. Make sure chain is designed for rocky soil. |
| | Teeth are not installed correctly or missing. | Check teeth sequence installation. Correct any teeth installed incorrectly. Replace any missing teeth. |
| Chain is not digging properly. | Chain runs backward. | See Problem: Chain runs backward. |
| | Chain is installed backward. | Reinstall chain on the trencher correctly. |
| | Chain is encountering hard or rocky soil or chain is encountering sandy soil. | Evaluate soil type and chain type. If mismatched, replace chain with one matched for your soil type. |
| | Excessive digging load. | Slow down ground speed. |
| | Teeth are dull, missing, broken, or loose. | Replace dull, missing, and broken teeth. Tighten loose teeth. |
| | Teeth sequence is installed incorrectly. | Check teeth sequence installation. Correct any teeth installed incorrectly. |
| Chain runs backward. | Hydraulic hose couplings are reversed. | Switch couplers on the hydraulic hoses. |
| Hydraulic oil leaks. | Damaged hydraulic hoses. | Replace damaged hydraulic hoses. |
| | Loose fittings or hydraulic hoses. | Tighten fittings and hydraulic hoses. |
| | Motor seals are worn or damaged. | Repair hydraulic motor. |
| Insufficient skid steer power. | Cold hydraulic oil or air in hydraulic lines. | Allow time for hydraulic oil to warm up by running the trencher out of the ground. |
| | Teeth are dull, broken, or loose. | Replace dull and broken teeth. Tighten loose teeth. |
| | Hydraulic system not working properly. | See Problem: Trencher stalls. |
| Manual side shift will not move. | Side shift rods are dirty and/or not lubricated. | Clean side shift rods of all dirt and lubricate with dry lubrication. |
| Selector valve handle will not move. | Hydraulic line pressure is too high. | Relieve skid steer line pressure to the unit. |
| Solid object jams between two teeth | Cutting through rock or other hard objects sized right to jam between the teeth. | Shutdown operation and manually remove object caught between the teeth. |
| Teeth are coming loose. | Vibration and chain movement. | Check nuts securing teeth frequently. |
| | Hard or rocky soil. | Add Loctite Threadlocker 242 to bolt threads and tighten loose nuts. |
| Teeth will not tighten. | Bolts are bent or threads are damaged. | Replace bent/damaged bolt and nut. |

Continue troubleshooting on next page.

Troubleshooting Chart

| Problem | Cause | Solution |
|---------------------------------------|--|--|
| Trencher stalls. | Quick connect couplings did not engage. | Reconnect quick couplings to skid steer. |
| | Hydraulic flow is inadequate. | Check hydraulic flow with a flow meter. If low, investigate cause and correct. |
| | Hydraulic flow is not engaged. | Engage skid steer hydraulics. |
| | Hydraulic hose has a break. | Replace hydraulic hose. |
| | Hydraulic hose has an obstruction. | Remove obstruction or replace hose. |
| | Hydraulic line is pinched. | Fix pinched line. |
| | Hydraulic lines have air in them. | Engage hydraulics to trencher until all air is purged from the hydraulic system. |
| | Hydraulic motor is damaged. | Repair hydraulic motor. |
| | Hydraulic reservoir is low on oil. | Add hydraulic oil to skid steer reservoir. |
| | Obstacles are entangled in chain or auger. | Reverse chain for 2 seconds and then switch back to original direction. If needed, manually clear chain or auger of obstacles. |
| | Rocks and other solid debris. | Lift chain boom up enough to allow chain to start again and then resume digging. |
| | Traveling too fast for soil conditions. | Slow down ground speed. |
| Trencher vibrates excessively. | Obstacles are entangled in the teeth. | Shutdown skid steer and trencher. Clear obstacles from the teeth. |
| | Rocks and other solid debris. | Normal for rocks and solid debris to cause vibration. |
| | Teeth are missing, broken, dull, or loose. | Replace missing, broken, and dull teeth. Tighten loose teeth. |

| Torque Values Chart for Common Bolt Sizes | | | | | | | | | | | | | |
|--|--------------------------|--------------------|---------|-------|---------|-------|--|------------------------------|-------|-----------|-------|------------|-------|
| Bolt Size (inches) | Bolt Head Identification | | | | | | Bolt Size (Metric) | Bolt Head Identification | | | | | |
| | Grade 2 | | Grade 5 | | Grade 8 | | | Class 5.8 | | Class 8.8 | | Class 10.9 | |
| in-tpi ¹ | N · m ² | ft-lb ³ | N · m | ft-lb | N · m | ft-lb | mm x pitch ⁴ | N · m | ft-lb | N · m | ft-lb | N · m | ft-lb |
| 1/4" - 20 | 7.4 | 5.6 | 11 | 8 | 16 | 12 | M 5 X 0.8 | 4 | 3 | 6 | 5 | 9 | 7 |
| 1/4" - 28 | 8.5 | 6 | 13 | 10 | 18 | 14 | M 6 X 1 | 7 | 5 | 11 | 8 | 15 | 11 |
| 5/16" - 18 | 15 | 11 | 24 | 17 | 33 | 25 | M 8 X 1.25 | 17 | 12 | 26 | 19 | 36 | 27 |
| 5/16" - 24 | 17 | 13 | 26 | 19 | 37 | 27 | M 8 X 1 | 18 | 13 | 28 | 21 | 39 | 29 |
| 3/8" - 16 | 27 | 20 | 42 | 31 | 59 | 44 | M10 X 1.5 | 33 | 24 | 52 | 38 | 72 | 53 |
| 3/8" - 24 | 31 | 22 | 47 | 35 | 67 | 49 | M10 X 1.25 | 35 | 26 | 53 | 39 | 76 | 56 |
| 7/16" - 14 | 43 | 32 | 67 | 49 | 95 | 70 | M12 X 1.75 | 58 | 42 | 91 | 67 | 125 | 93 |
| 7/16" - 20 | 49 | 36 | 75 | 55 | 105 | 78 | M12 X 1.5 | 60 | 44 | 95 | 70 | 130 | 97 |
| 1/2" - 13 | 66 | 49 | 105 | 76 | 145 | 105 | M12 X 1 | 90 | 66 | 105 | 77 | 145 | 105 |
| 1/2" - 20 | 75 | 55 | 115 | 85 | 165 | 120 | M14 X 2 | 92 | 68 | 145 | 105 | 200 | 150 |
| 9/16" - 12 | 95 | 70 | 150 | 110 | 210 | 155 | M14 X 1.5 | 99 | 73 | 155 | 115 | 215 | 160 |
| 9/16" - 18 | 105 | 79 | 165 | 120 | 235 | 170 | M16 X 2 | 145 | 105 | 225 | 165 | 315 | 230 |
| 5/8" - 11 | 130 | 97 | 205 | 150 | 285 | 210 | M16 X 1.5 | 155 | 115 | 240 | 180 | 335 | 245 |
| 5/8" - 18 | 150 | 110 | 230 | 170 | 325 | 240 | M18 X 2.5 | 195 | 145 | 310 | 230 | 405 | 300 |
| 3/4" - 10 | 235 | 170 | 360 | 265 | 510 | 375 | M18 X 1.5 | 220 | 165 | 350 | 260 | 485 | 355 |
| 3/4" - 16 | 260 | 190 | 405 | 295 | 570 | 420 | M20 X 2.5 | 280 | 205 | 440 | 325 | 610 | 450 |
| 7/8" - 9 | 225 | 165 | 585 | 430 | 820 | 605 | M20 X 1.5 | 310 | 230 | 650 | 480 | 900 | 665 |
| 7/8" - 14 | 250 | 185 | 640 | 475 | 905 | 670 | M24 X 3 | 480 | 355 | 760 | 560 | 1050 | 780 |
| 1" - 8 | 340 | 250 | 875 | 645 | 1230 | 910 | M24 X 2 | 525 | 390 | 830 | 610 | 1150 | 845 |
| 1" - 12 | 370 | 275 | 955 | 705 | 1350 | 995 | M30 X 3.5 | 960 | 705 | 1510 | 1120 | 2100 | 1550 |
| 1-1/8" - 7 | 480 | 355 | 1080 | 795 | 1750 | 1290 | M30 X 2 | 1060 | 785 | 1680 | 1240 | 2320 | 1710 |
| 1-1/8" - 12 | 540 | 395 | 1210 | 890 | 1960 | 1440 | M36 X 3.5 | 1730 | 1270 | 2650 | 1950 | 3660 | 2700 |
| 1-1/4" - 7 | 680 | 500 | 1520 | 1120 | 2460 | 1820 | M36 X 2 | 1880 | 1380 | 2960 | 2190 | 4100 | 3220 |
| 1-1/4" - 12 | 750 | 555 | 1680 | 1240 | 2730 | 2010 | ¹ in-tpi = nominal thread diameter in inches-threads per inch ² N · m = newton-meters ³ ft-lb= foot pounds ⁴ mm x pitch = nominal thread diameter in millimeters x thread pitch | | | | | | |
| 1-3/8" - 6 | 890 | 655 | 1990 | 1470 | 3230 | 2380 | | | | | | | |
| 1-3/8" - 12 | 1010 | 745 | 2270 | 1670 | 3680 | 2710 | | | | | | | |
| 1-1/2" - 6 | 1180 | 870 | 2640 | 1950 | 4290 | 3160 | | | | | | | |
| 1-1/2" - 12 | 1330 | 980 | 2970 | 2190 | 4820 | 3560 | | | | | | | |
| Torque tolerance + 0%, -15% of torquing values. Unless otherwise specified use torque values listed above. All locknuts or lubricated fasteners: Use 75% of torque value. (i.e. 1/2"-13 GR5 = 76 ft-lb; 75% of 76 or .75 x 76 = 57 ft-lb) | | | | | | | | | | | | | |
| Additional Torque Values | | | | | | | | | | | | | |
| 8 - 5/8-11 Special 12 point flange head bolt for the sprocket/auger mount. | | | | | | | | 135-150 ft-lbs. (183-203 Nm) | | | | | |
| 12 - 1/2"-13 Hex flange locknuts for the boom mount frame. | | | | | | | | 90-105 ft-lbs. (122-203 Nm) | | | | | |

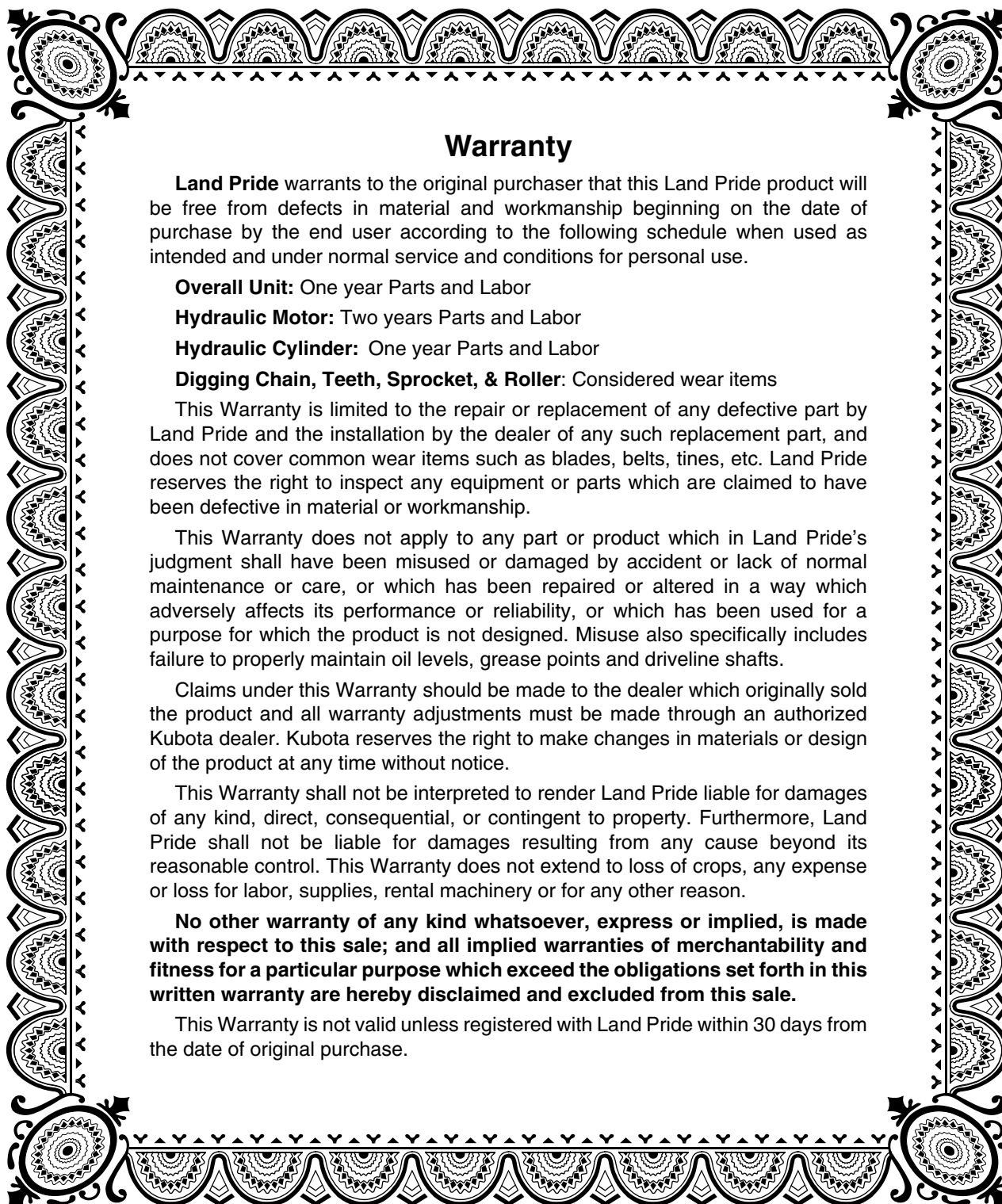

Warranty

Land Pride warrants to the original purchaser that this Land Pride product will be free from defects in material and workmanship beginning on the date of purchase by the end user according to the following schedule when used as intended and under normal service and conditions for personal use.

Overall Unit: One year Parts and Labor

Hydraulic Motor: Two years Parts and Labor

Hydraulic Cylinder: One year Parts and Labor

Digging Chain, Teeth, Sprocket, & Roller: Considered wear items

This Warranty is limited to the repair or replacement of any defective part by Land Pride and the installation by the dealer of any such replacement part, and does not cover common wear items such as blades, belts, tines, etc. Land Pride reserves the right to inspect any equipment or parts which are claimed to have been defective in material or workmanship.

This Warranty does not apply to any part or product which in Land Pride's judgment shall have been misused or damaged by accident or lack of normal maintenance or care, or which has been repaired or altered in a way which adversely affects its performance or reliability, or which has been used for a purpose for which the product is not designed. Misuse also specifically includes failure to properly maintain oil levels, grease points and driveline shafts.

Claims under this Warranty should be made to the dealer which originally sold the product and all warranty adjustments must be made through an authorized Kubota dealer. Kubota reserves the right to make changes in materials or design of the product at any time without notice.

This Warranty shall not be interpreted to render Land Pride liable for damages of any kind, direct, consequential, or contingent to property. Furthermore, Land Pride shall not be liable for damages resulting from any cause beyond its reasonable control. This Warranty does not extend to loss of crops, any expense or loss for labor, supplies, rental machinery or for any other reason.

No other warranty of any kind whatsoever, express or implied, is made with respect to this sale; and all implied warranties of merchantability and fitness for a particular purpose which exceed the obligations set forth in this written warranty are hereby disclaimed and excluded from this sale.

This Warranty is not valid unless registered with Land Pride within 30 days from the date of original purchase.

IMPORTANT: The Online Warranty Registration should be completed by the dealer at the time of purchase. This information is necessary to provide you with quality customer service.

Model Number _____

Serial Number _____

Legal Disclaimer

Kubota Corporation notes that specifications and technical information are subject to change without notice and Kubota does not represent or warrant that the information in this publication is completely accurate or current; however, Kubota used reasonable efforts to set forth and include accurate and up to date information in this publication. Kubota disclaims all representations and warranties, whether express or implied, including, but not limited to, warranties of merchantability and fitness for a particular purpose and Kubota shall not be liable for any damages, whether compensatory, direct, indirect, incidental, special, or consequential, arising out of or in connection with the use of this publication, or in the information therein.

The Product(s) described in this Publication are designed and manufactured only for the country in which they are initially wholesaled by Kubota. Kubota does not provide parts, warranty or service for any Product which is re-sold or retailed in any country other than the country for which the Product(s) were designed or manufactured.

Kubota®

Kubota HP: <https://www.kubota.com/network/index.html>